

Volume II

# CNMI and Guam Stormwater Management Manual

Final – October 2006



Prepared by:  
**Horsley Witten Group, Inc.**



Prepared for:  
**Commonwealth of the Northern Mariana Islands  
and the Territory of Guam**



**<This page left blank intentionally>**



## *Table of Contents*

<b>1.0</b>	<b>Introduction to Volume II</b>	
1.1	Chapter Descriptions.....	1-1
1.2	General Information.....	1-3
1.3	Symbols and Acronyms .....	1-4
<b>2.0</b>	<b>Selecting the Most Effective Stormwater Treatment System</b>	
2.1	Step 1-Land Use.....	2-2
2.2	Step 2-Physical Feasibility.....	2-4
2.3	Step 3-Watershed.....	2-6
2.4	Step 4-Stormwater Management Capability.....	2-8
2.5	Step 5-Pollutant Removal Constraints .....	2-10
2.6	Step 6-Community and Environmental .....	2-11
<b>3.0</b>	<b>Better Site Design and Non-Structural BMPs</b>	
3.1	Definition of Better Site Design .....	3-1
3.2	Goals of Better Site Design.....	3-1
3.3	Benefits of Better Site Design.....	3-2
3.4	Better Site Design Planning Process .....	3-2
3.5	Better Site Design Categories.....	3-2
3.6	Better Site Design Best Management Practices.....	3-3
<b>4.0</b>	<b>Design Examples</b>	
4.1	Case Study #1: Medium-Density Residential Site in Guam.....	4-2
4.1.1	Stormwater Wet Pond Design Example .....	4-4
4.1.2	Dry Swale Design Example.....	4-13
4.1.3	Infiltration Basin Design Example.....	4-21
4.2	Case Study #2: Commercial Site in Guam .....	4-27
4.2.1	Bioretention Design Example with Grass Channel Pretreatment.....	4-29
4.2.2	Bioretention Design Example with Filter Strip Pretreatment.....	4-35
4.2.3	Sand Filter Design Example .....	4-37
4.3	Case Study #3: Commercial Site in CNMI.....	4-43
4.3.1	Infiltration Chamber Design Example with Grass Channel and Oil/Grit Separator Pretreatment.....	4-44
4.4	Case Study #4: Single-Family Residential Site in CNMI.....	4-49
4.4.1	Cistern and Drywell .....	4-50

4.4.2	Rain Garden .....	4-52
4.4.3	Permeable Pavers .....	4-52
4.4.4	Swale .....	4-52
<b>5.0</b>	<b>Landscaping Guidance</b>	
5.1	General Landscaping Guidance for all BMPs .....	5-2
5.2	Ponds and Wetlands .....	5-4
5.3	Infiltration and Sand Filters .....	5-9
5.4	Bioretention .....	5-9
5.5	Open Channels .....	5-12
5.6	Other Considerations in Stormwater BMP Landscaping .....	5-13
<b>6.0</b>	<b>BMP Sample Design and Construction Specifications</b>	
6.1	Design Specifications for Embankments .....	6-1
6.2	Construction Specifications for Ponds/Wetlands .....	6-19
6.3	Construction Specifications for Infiltration BMPs .....	6-35
6.4	Construction Specifications for Filter BMPs .....	6-45
6.5	Construction Specifications for Open Channels .....	6-59
<b>7.0</b>	<b>Maintenance Plans</b>	
7.1	Maintenance Guidance/Descriptions .....	7-2
7.2	Maintenance and Inspection Checklists .....	7-7
7.3	Sample Stormwater Facility Maintenance Agreement .....	7-25
<b>8.0</b>	<b>Soils Information</b>	
8.1	Introduction to Soils .....	8-1
8.2	Test Pit Procedure .....	8-4
<b>9.0</b>	<b>Assorted Design Tools</b>	
9.1	Infiltration and Bioretention Testing Requirements .....	9-1
9.2	Miscellaneous BMP Details .....	9-5
9.3	Hydrologic Analysis Tools .....	9-13

## Glossary

## References

**LIST OF FIGURES**

Figure 3.1	Example of Natural Resource Inventory Plan .....	3-4
Figure 3.2	Fit the design of a site to the terrain and natural features.....	3-5
Figure 3.3	Residential Road in Saipan that seems much wider than necessary to accommodate residential traffic flow.....	3-6
Figure 3.4	Examples of Permeable Pavers .....	3-7
Figure 3.5	Turnaround Options for Residential Streets.....	3-7
Figure 3.6	Use of a Grassed Filter Strip .....	3-8
Figure 3.7	Dry Well.....	3-9
Figure 3.8	Rooftop runoff is directed to a landscaped area around this house in Saipan.....	3-10
Figure 3.9	Residential Subdivision - Conventional Design and Better Site Design.....	3-12
Figure 3.10	Commercial Development - Conventional Design and Better Site Design .....	3-13
Figure 4.1	Medium Density Residential Site Plan in Guam.....	4-3
Figure 4.2	Plan View of Pond Grading for Residential Site on Guam (Not to Scale).....	4-5
Figure 4.3	Storage-Elevation Table/Curve for Pond Design.....	4-6
Figure 4.4	Profile of Principal Spillway .....	4-11
Figure 4.5	Plan View and Cross-Section of Dry Swale.....	4-14
Figure 4.6	Plan View of Infiltration Basin.....	4-21
Figure 4.7	Cross-Section of Infiltration Basin.....	4-22
Figure 4.8	Capitol Beach Shopping Center - Commercial Site Plan on Guam.....	4-28
Figure 4.9	Plan View of Bioretention with Grass Swale.....	4-29
Figure 4.10	Typical Sections of a Bioretention Facility and a Grass Swale.....	4-30
Figure 4.11	Flow Splitter Design.....	4-33
Figure 4.12	Plan View of Bioretention with Filter Strip .....	4-35
Figure 4.13	Plan View of Sand Filter .....	4-37
Figure 4.14	Profile and Plan Views of Sand Filter .....	4-38
Figure 4.15	Sunshine Market Site Plan on Saipan.....	4-43
Figure 4.16	Typical Detail of an Oil/Grit Separator .....	4-44
Figure 4.17	Typical Detail of Infiltration Chambers .....	4-45
Figure 4.18	Single-family Residential Site Plan on Tinian .....	4-49
Figure 4.19	Detail of Cistern and Drywell.....	4-50
Figure 4.20	Detail of Permeable Pavers .....	4-52
Figure 5.1	Planting Zones for Stormwater Ponds and Wetlands.....	5-5
Figure 5.2	Planting Zones for Bioretention Facilities.....	5-11
Figure 8.1	USDA Textural Classification Triangle .....	8-2
Figure 8.2	Field Procedure for Determining USDA Textural Classification .....	8-3
Figure 8.3	Participants of the May 2006 Stormwater Training Workshop in Saipan Learn how to Evaluate a Test Pit .....	8-4
Figure 8.4	Sample Test Pit Form .....	8-6
Figure 9.1	Trash Rack Protection for Low-flow Orifice .....	9-5
Figure 9.2	Expanded Trash Rack Protection for Low Flow Orifice.....	9-6
Figure 9.3	Internal Control for Orifice Protection .....	9-6
Figure 9.4	Half Round CMP Hood.....	9-7
Figure 9.5	Observation Well for Infiltration Practices .....	9-8
Figure 9.6	On-line Versus Off-line Schematic .....	9-9
Figure 9.7	Isolation/Diversion Structure.....	9-10

Figure 9.8 Concrete Level Spreader .....	9-11
Figure 9.9 Detention Time vs. Discharge Ratios (Source: MDE, 2000) .....	9-14
Figure 9.10 Approximate Detention Basin Routing For Rainfall Types I, IA, II, and III .....	9-14

## LIST OF TABLES

Table 1.1 Key Symbols and Acronyms Cited in Manual .....	1-4
Table 2.1 BMP Selection Matrix 1-Land Use .....	2-3
Table 2.2 BMP Selection Matrix 2-Physical Feasibility .....	2-5
Table 2.3 BMP Selection Matrix 3-Watershed .....	2-7
Table 2.4 BMP Selection Matrix 4-Stormwater Management Capability .....	2-9
Table 2.5 BMP Selection Matrix 5-Pollutant Removal .....	2-10
Table 2.6 BMP Selection Matrix 6-Community and Environmental .....	2-12
Table 3.1 Better Site Design General Categories and Specific BMPs .....	3-3
Table 4.1 Base Data for Mountain View Estates .....	4-2
Table 4.2 Summary of General Storage Requirements for Mountain View Estates, Catchment B .....	4-4
Table 4.3 Stage-Storage-Discharge Summary for Pond Example .....	4-8
Table 4.4 Sample TR-55 Results from HydroCAD .....	4-9
Table 4.5 Summary of Controls Provided for Pond Example .....	4-10
Table 4.6 Base Data for Mountain View Estates – Dry Swale .....	4-13
Table 4.7 Mountain View Estates “A” Post-Developed - TR-55 Output for 1- and 2-year storm events .....	4-17
Table 4.8 Base Data for Mountain View Estates – Infiltration Basin .....	4-21
Table 4.9 Mountain View Estates “A” Post-Developed - TR-55 Output for 1- and 25-year storm events .....	4-23
Table 4.10 Site Specific Data for Mountain View Estates .....	4-23
Table 4.11 Infiltration Basin Feasibility .....	4-24
Table 4.12 Base Data for Capitol Beach Shopping Center .....	4-27
Table 4.13 Summary of Post-development Hydrologic Data for Catchment C .....	4-39
Table 4.14 Sunshine Market Base Data .....	4-44
Table 4.15 Site Specific Data for Sunshine Market .....	4-46
Table 4.16 Infiltration Chambers Feasibility .....	4-46
Table 4.17 Tinian Single Family Home Base Data .....	4-50
Table 5.1 Hydrologic Zones .....	5-4
Table 5.2 Planting Soil Characteristics .....	5-10
Table 5.3 Planting Plan Design Considerations .....	5-11
Table 5.4 Planting Specification Issues for Bioretention Areas .....	5-12
Table 5.5 Common Grass Species for Dry and Wet Swales and Grass Channels .....	5-12
Table 6.1 Hydrologic Criteria for Ponds .....	6-15
Table 6.2 Minimum Top Width of Embankments .....	6-16
Table 6.3 Minimum Gages – Steel Pipe .....	6-16
Table 6.4 Minimum Gages – Aluminum Pipe .....	6-16
Table 6.5 Acceptable Plastic Pipe for Use in Earth Dams .....	6-17
Table 6.6 Stormwater Pond/Wetland Construction Inspection Checklist .....	6-25
Table 6.7 Infiltration Trench/Chamber Construction Inspection Checklist .....	6-35

Table 6.8 Infiltration Basin Construction Inspection Checklist.....	6-38
Table 6.9 Watertightness Testing Procedure/Criteria for Precast Concrete Tanks .....	6-42
Table 6.10 Materials Specifications for Sand Filters.....	6-42
Table 6.11 Sand Filter Inspection Checklist.....	6-43
Table 6.12 Materials Specifications for Bioretention.....	6-48
Table 6.13 Bioretention Construction Inspection Checklist.....	6-49
Table 6.14 Open Channel Materials Specifications.....	6-53
Table 6.15 Open Channel System Construction Inspection Checklist .....	6-54
Table 9.1 Infiltration Testing Summary Table .....	9-2

**<This page left blank intentionally>**





## *1.0 Introduction to Volume II*

This is the second volume of the two-volume Stormwater Management Manual created for the Commonwealth of Northern Mariana Islands (CNMI) and the Territory of Guam. Volume I of the CNMI/Guam Stormwater Management Manual provides designers a general overview on local stormwater issues, lists the stormwater performance standards for the islands, and describes how to size and design BMPs to comply with those standards. This volume contains more detailed information on how to select and locate BMPs at a development site, how to prepare effective landscaping plans for stormwater practices, BMP construction specifications, step-by-step BMP design examples and other assorted design tools.

### **1.1 Chapter Descriptions**

Volume II contains the technical information needed to actually design, landscape, and construct a BMP. There are a total of nine chapters, including:

Chapter 1. Introduction to Volume II.

Chapter 2. Selecting and Locating the Most Effective BMP System. This chapter presents guidance on how to select the best BMP or group of practices at a development site, as well as describing environmental and other factors to consider when actually locating each BMP. The chapter contains six comparative matrices that evaluate BMPs from the standpoint of the following factors:

- ▶ Land Use
- ▶ Physical Feasibility
- ▶ Watershed
- ▶ Stormwater Management Capability
- ▶ Pollutant Removal
- ▶ Community and Environmental

Chapter 2 is designed so that the reader can use the matrices in a step-wise fashion to identify the most appropriate BMP or group of practices to use at a site.

Chapter 3. Better Site Design and Non-structural BMPs. This chapter presents a suite of methods that designers and developers can take advantage of to reduce the stormwater runoff at a site. These methods are grouped into the following three categories: Preservation of Natural Features and Conservation Design, Reduction of Impervious Cover, and Utilization

of Natural Features and Source Control for Stormwater Management.

Chapter 4. Step-by-Step Design Examples. Four case studies are presented to help designers and plan reviewers better understand the new criteria in this Manual. The examples demonstrate how the new stormwater sizing criteria are applied, as well as some of the design procedures and performance criteria that should be considered when siting and designing a stormwater best management practice. A stormwater design for a typical single-lot development is also included.

Chapter 5. Landscaping Guidance. Good landscaping can often be an important factor in the performance and community acceptance of many stormwater BMPs. The Landscaping Guide provides general background on how to determine the appropriate landscaping region and hydrologic zone in CNMI and Guam. Chapter 5 also includes tips on how to establish more functional landscapes within stormwater BMPs.

Chapter 6. BMP Design and Construction Specifications. Good designs only work if careful attention is paid to proper construction techniques and materials. Chapter 6 contains detailed specifications for constructing ponds/wetlands, infiltration practices, filters, and open channels.

Chapter 7. Maintenance Plans. On-going maintenance is vital to ensure that BMPs continue to function as designed. Chapter 7 includes guidance on creating an appropriate maintenance plan, example checklists that can be incorporated in the plan, and a sample maintenance agreement to ensure the plan is implemented.

Chapter 8. Soils Information. One of the most important site characteristics to consider when choosing stormwater BMPs is the type of soil at that location. Chapter 8 provides a brief introduction to soils, as well as a description of field procedures needed when evaluating a test pit.

Chapter 9. Assorted Design Tools. Chapter 9 provides additional information to help designers with the incorporation of stormwater BMPs at their site. This chapter includes sections on infiltration and bioretention testing requirements, miscellaneous BMP details, and hydrologic analysis tools.

## **1.2 General Information**

### **How to Order Printed Copies of the Manual**

Printed copies of the Manual or the Manual on CD can be ordered by calling the CNMI DEQ at 670-664-8500 or the Guam EPA at 671-475-1635.

### **How to Find the Manual on the Internet**

Both volumes of the CNMI/Guam Stormwater Management Manual are also available in Adobe Acrobat PDF document format for download at the following Internet addresses:

CNMI Division of Environmental Quality: <http://www.deq.gov.mp/>

Guam Environmental Protection Agency: <http://www.guamepa.govguam.net/>

### **Key Contact Information for Permitting in CNMI and Guam**

If you have any technical questions or comments on the Manual, please send an email to:

Brian Bearden (CNMI DEQ) [brian.bearden@deq.gov.mp](mailto:brian.bearden@deq.gov.mp) or Domingo Cabusao (GEPA) [dcabusao@guamepa.govguam.net](mailto:dcabusao@guamepa.govguam.net).

### 1.3 Symbols and Acronyms

As an aid to the reader, the following table outlines the symbols and acronyms that are used throughout the text. In addition, a glossary is provided at the end of this volume that defines the terminology used in the text.

<b>Table 1.1 Key Symbols and Acronyms Cited in Manual</b>			
A	drainage area	Qi	peak inflow discharge
BMP	best management practice	Qo	peak outflow discharge
cfs	cubic feet per second	Qp	overbank flood control storage volume
Cp <sub>v</sub>	channel protection storage volume	qu	unit peak discharge
CMP	corrugated metal pipe	Re <sub>v</sub>	recharge volume
CN	curve number	R/W	right of way
ED	extended detention	SD	separation distance
f <sub>c</sub>	soil infiltration rate	t <sub>c</sub>	time of concentration
fps	feet per second	TR-55	Technical Release No. 55 Urban Unit Hydrology for Small Watersheds
HSG	hydrologic soil group	TSS	total suspended solids
Ia	initial abstraction	Vr	volume of runoff
I	percent impervious cover	Vs	volume of storage
K	coefficient of permeability	Vt	total volume
NRCS	Natural Resources Conservation Service	Vv	volume of voids
P	precipitation depth	WQ <sub>v</sub>	water quality storage volume
		WSE	water surface elevation



## *2.0 Selecting and Locating the Most Effective Best Management Practices*

This section presents a series of matrices that can be used as a screening process for selecting the best BMP or group of BMPs for a development site. It also provides guidance for locating practices on the site. The matrices presented can be used to screen practices in a step-wise fashion. Screening factors include:

- Land Use
- Physical Feasibility
- Watershed
- Stormwater Management Capability
- Pollutant Removal
- Community and Environmental

The six matrices presented here are not exhaustive. Specific additional criteria may be incorporated depending on local design knowledge and resource protection goals. Caveats for the application of each matrix are included in the detailed description of each.

More detail on the proposed step-wise screening process is provided below:

### Step 1- Land Use

*Which practices are best suited for the proposed land use at this site?* In this step, the designer makes an initial screen to select practices that are best suited to a particular land use.

### Step 2 - Physical Feasibility

*Are there any physical constraints at the project site that may restrict or preclude the use of a particular BMP?* For this step, the designer screens the BMP list using Matrix No. 2 to determine if the soils, water table, drainage area, slope or head conditions present at a particular development site might limit the use of a BMP.

### Step 3 - Watershed

*What watershed protection goals need to be met in the resource my site drains to?* Matrix No.3 outlines BMP goals and restrictions based on the resource being protected.

#### Step 4 - Stormwater Management Capability

*Can one BMP meet all design criteria, or is a combination of practices needed?* In this step, designers can screen the BMP list using Matrix No. 4 to determine if a particular BMP can meet recharge, water quality, channel/overland flow protection, and flood control storage requirements. At the end of this step, the designer can screen the BMP options down to a manageable number and determine if a single BMP or a group of BMPs are needed to meet stormwater sizing criteria at the site.

#### Step 5 - Pollutant Removal

*How do each of the BMP options compare in terms of pollutant removal?* In this step, the designer views removal of select pollutants to determine the best BMP options for water quality.

#### Step 6 - Community and Environmental

*Do the remaining BMPs have any important community or environmental benefits or drawbacks that might influence the selection process?* In this step, a matrix is used to compare the BMP options with regard to maintenance, habitat, community acceptance, cost and other environmental factors.

## **2.1 Step 1 - Land Use**

This matrix allows the designer to make an initial screen of practices most appropriate for a given land use.

*Rural.* This column identifies BMPs that are best suited to treat runoff in rural or very low density areas (e.g., typically at a density of less than ½ dwelling unit per acre).

*Residential.* This column identifies the best treatment options in medium to high density residential developments.

*Roads and Highways.* This column identifies the best practices to treat runoff from major roadway and highway systems.

*Commercial Development.* This column identifies practices that are suitable for new commercial development.

*Hotspot Land Uses.* This column examines the capability of BMPs to treat runoff from designated hotspots. BMPs that receive hotspot runoff may have design restrictions, as noted.

*Ultra-Urban Sites.* This column identifies BMPs that work well in the ultra-urban environment, where space is limited and original soils have been disturbed. These BMPs are frequently used at redevelopment and infill sites.

**Table 2.1 BMP Selection Matrix 1-Land Use**

BMP Group	BMP Design	Rural	Residential	Roads and Highways	Commercial/High Density	Hotspots	Ultra Urban
Pond	Micropool ED	○	○	○	◐	①	●
	Wet Pond	○	○	○	◐	①	●
	Wet ED Pond	○	○	○	◐	①	●
Wetland	Shallow Marsh	○	○	◐	◐	①	●
	ED Wetland	○	○	◐	◐	①	●
	Pocket Wetland/Pond	○	◐	○	◐	●	●
Infiltration	Infiltration Trench/Chambers	◐	◐	○	○	●*	◐
	Shallow I-Basin	◐	◐	◐	◐	●*	◐
Filters	Sand Filter	●	●	◐	○	②	○
	Organic Filter	●	◐	○	○	②	○
	Bioretention	◐	◐	○	○	②	○
Open Channels	Dry Swale	○	◐	○	◐	②	◐
	Wet Swale	○	●	○	●	●	●

○: Yes. Good option in most cases.  
 ◐: Depends. Suitable under certain conditions, or may be used to treat a portion of the site.  
 ●: No. Seldom or never suitable.  
 ①: Acceptable option, but may require a pond liner to reduce risk of groundwater contamination.  
 ②: Acceptable option, if not designed as an exfilter. (An exfilter is a conventional stormwater filter without an underdrain system. The filtered volume ultimately infiltrates into the underlying soils.)

\* Infiltration practices may be used for quantity control at hotspots as long as 100% of water quality volume is treated prior to infiltration.

## 2.2 Step 2 - Physical Feasibility

This matrix allows the designer to evaluate possible options based on physical conditions at the site. More detailed testing protocols are often needed to confirm these conditions. Five primary factors are:

*Soils.* The key evaluation factors are based on an initial investigation of the NRCS hydrologic soil groups at the site. Note that more detailed geotechnical tests are usually required for infiltration feasibility and during design to confirm permeability and other factors (see **Chapters 8 and 9** for more on soils and geotechnical tests).

*Water Table.* This column indicates the minimum depth to the seasonally high water table from the bottom elevation, or floor, of a BMP.

*Drainage Area.* This column indicates the minimum or maximum drainage area that is considered optimal for a practice. If the drainage area present at a site is slightly greater than the maximum allowable drainage area for a practice, some leeway is warranted where a practice meets other management objectives. Likewise, the minimum drainage areas indicated for ponds and wetlands should not be considered inflexible limits, and may be increased or decreased depending on water availability (baseflow or groundwater), mechanisms employed to prevent clogging, or the ability to assume an increased maintenance burden.

*Slope.* This column evaluates the effect of slope on the practice. Specifically, the slope guidance refers to how flat the area where the practice is installed must be and/or how steep the contributing drainage area or flow length can be.

*Head.* This column provides an estimate of the elevation difference needed for a practice (from the inflow to the outflow) to allow for gravity operation.



**Table 2.2 BMP Selection Matrix 2-Physical Feasibility**

BMP Group	BMP Design	Soils <sup>1</sup>	Water Table	Drainage Area (Ac)	Site Slope <sup>2</sup>	Head (Ft)
Pond	Micropool ED	Limestone and HSG A soils require pond liner	3 ft* separation if hotspot or aquifer	10 min**	No more than 15%	6 to 8 ft
	Wet Pond			25 min**		
	Wet ED Pond					
Wetland	Shallow Marsh	Limestone and HSG A soils require liner	3 ft* separation if hotspot or aquifer	25 min	No more than 8%	3 to 5 ft
	ED Wetland					
	Pocket Wetland/Pond	OK	below WT	5 max****		4 ft
Infiltration	Infiltration Trench/Chamber	$f_c > 0.5^{*3}$ inch/hr	3 ft*	5 max	No more than 6%	1 ft
	Infiltration Basin			10 max		3 ft
Filters	Sand Filter	OK	2 ft	10 max ***	no more than 6%	2 to 7 ft
	Organic Filter			5 max****		2 to 4 ft
	Bioretention	Made Soil	5 ft			
Open Channels	Dry Swale	Made Soil	2 ft	5 max	No more than 4%	3 to 5 ft
	Wet Swale	OK	below WT	5 max		1 ft

Notes: OK= not restricted, WT= water table,  $f_c$  =soil permeability  
 \* denotes a required limit, other elements are planning level guidance and may vary somewhat depending on site conditions  
 \*\* unless adequate water balance and anti-clogging device installed  
 \*\*\*\*drainage area can be larger in some instances.

<sup>1</sup> Please note that the HSG types listed in the CNMI Stormwater Control Handbook (1989) are incorrect. Refer to the Soil Survey for the correct values.

<sup>2</sup> Refers to post-construction slope at the BMP site.

<sup>3</sup> Soil matrix must extend at least 3 feet below bottom of practice if being used to meet water quality criteria – if a deep soil profile does not exist, another BMP must be used prior to infiltration for treatment of WQ<sub>v</sub>.

## 2.3 Step 3 - Watershed

The design and implementation of stormwater management control measures is strongly influenced by the nature and sensitivity of the receiving waters. In some cases higher pollutant removal, more recharge or other environmental performance is warranted to fully protect the resource quality, human health and/or safety. Based on the discussions in **Volume I – Chapter 1**, critical resource areas include: *groundwater, freshwater streams, ponds, wetlands, and coastal waters*. **Table 2.3** presents the key design variables and considerations that must be addressed for sites that drain to any of the above critical resource areas. Because of the islands' small size, all sites on Guam and in the CNMI can be assumed to drain into one or more of the critical resource areas.

**Table 2.3 BMP Selection Matrix 3-Watershed**

BMP Group	Critical Resource Area Specific Criteria				
	Groundwater	Freshwater Streams	Freshwater Ponds	Freshwater Wetlands	Coastal Waters
Ponds	Pre-treat hotspots. Provide 2 ft SD from seasonal high GW elevation, 3 ft SD if hotspot or aquifer. Pretreat hotspots at 100% of $WQ_v$ .	Overland erosion and channel protection necessary ( $Cp_v$ ).	Design for enhanced TP removal. Use ponds with wetlands to increase TP removal.	Design for enhanced TP removal. Use ponds with wetlands to increase TP removal.	Moderate bacteria removal. Good to moderate TN removal. Provide permanent pools
Wetlands	Same as ponds	Same as ponds.	Same as ponds. Use Ponds/wetlands to increase TP removal.	Same as ponds. Use Ponds/wetlands to increase TP removal.	Provide long ED (> 48 hrs) for maximum bacteria dieoff.
Infiltration	100 ft SD from water supply wells. Pre-treat runoff in limestone regions at 90% Rule for $WQ_v$ .	OK, but soils overlaying volcanic dominated regions may limit application.	OK, if site has appropriate soils. Highest TP removal.	OK, if site has appropriate soils. Highest TP removal.	OK, but maintain 3 ft SD from seasonal high GW. TN removal is increased if placed within B soil horizon.
Filtering Systems	OK, ideal practice for pretreatment prior to infiltration.	Practices rarely can provide $Cp_v$ or $Q_{p-25}$ , other detention needed.	OK, moderate to high TP removal.	OK, moderate to high TP removal	OK, moderate to high bacteria and nitrogen removal
Open Channels	Pre-treat hotspots at 90% Rule for $WQ_v$ .	OK, should be linked w/ basin to provide $Cp_v$ or $Q_{p-25}$ .	OK, Dry swale provides more TP removal than wet swale.	OK, Dry swale provides more TP removal than wet swale.	Poor bacteria removal.
Detention	Does not meet $WQ_v$ pretreatment requirements.	Needed to provide $Cp_v$ and $Q_{p-25}$ .	Generally not necessary if directly discharging to large lake.		Generally not necessary, $Cp_v$ and $Q_{p-25}$ not required.

SD = separation distance, ED = extended detention, GW = groundwater

## 2.4 Step 4 - Stormwater Management Capability

This matrix examines the capability of each BMP option to meet stormwater management criteria. It shows whether a BMP can meet requirements for:

*Recharge.* The matrix indicates whether each practice can provide groundwater recharge, in support of recharge requirements. It may also be possible to meet this requirement using Better Site Design (see **Chapter 3** below).

*Water Quality.* The matrix tells whether each practice can be used to provide water quality treatment effectively. For more detail, consult the pollutant removal matrix, Matrix 5.

*Channel Protection.* The matrix indicates whether the BMP can typically provide channel protection storage. Finding that a particular BMP cannot meet the channel protection requirement does not necessarily imply that the BMP should be eliminated from consideration, but is a reminder that more than one practice may be needed at a site (e.g., a bioretention area and a downstream stormwater detention pond).

*Quantity Control.* The matrix shows whether a BMP can typically meet the overbank and extreme event flooding criteria for the site. Again, if a particular BMP cannot meet these requirements does not necessarily mean that it should be eliminated from consideration, but rather is a reminder that more than one practice may be needed at a site (e.g., a bioretention area and a downstream stormwater detention pond).

**Table 2.4 BMP Selection Matrix 4-Stormwater Management Capability**

<b>BMP Group</b>	<b>BMP Design</b>	<b>Recharge?</b>	<b>Water Quality?</b>	<b>Channel Protection?</b>	<b>Flood Control?</b>
Pond	Micropool ED	●	○	○	○
	Wet Pond	●	○	○	○
	Wet ED Pond	●	○	○	○
Wetland	Shallow Marsh	●	○	○	○
	ED Wetland	●	○	○	○
	Pocket Wetland/ Pond	●	○	○	○
Infiltration	Infiltration Trench/Chambers	○	①	③	④
	Shallow I-Basin	○	①	③	④
Filters	Sand Filter	②	○	③	●
	Organic Filter	②	○	●	●
	Bioretention	②	○	③	●
Open Channels	Dry Swale	②	○	●	●
	Wet Swale	●	○	●	●

○ Practice generally meets this stormwater management goal.  
 ● Practice can almost never be used to meet this goal.  
 ① Only provides water quality treatment if soil matrix extends at least 3 feet below bottom of practice.  
 ② Provides recharge only if designed as an exfilter system.  
 ③ Practice may partially meet this goal, or under specific site and design conditions.  
 ④ Can be used to meet flood control in highly permeable soils or limestone.

## 2.5 Step 5 - Pollutant Removal

This matrix examines the capability of each BMP option to remove specific pollutants from stormwater runoff. The matrix includes data for:

- Total Suspended Solids
- Total Phosphorous
- Total Nitrogen
- Metals
- Bacteria
- Hydrocarbons

**Table 2.5 BMP Selection Matrix 5-Pollutant Removal**

Practice	TSS [%]	TP [%]	TN [%]	Metals <sup>1</sup> [%]	Bacteria [%]	Hydrocarbons [%]
Wet Ponds	80	51	33	62	70	81 <sup>2</sup>
Stormwater Wetlands	76	49	30	42	78 <sup>2</sup>	85 <sup>2</sup>
Filtering Practices	86	59	38	69	37 <sup>2</sup>	84 <sup>2</sup>
Infiltration Practices <sup>3</sup>	95 <sup>2</sup>	80	51	99 <sup>2</sup>	N/A <sup>5</sup>	N/A
Open Channels <sup>4</sup>	81	34	84 <sup>2</sup>	70	N/A	62 <sup>2</sup>

1. Average of zinc and copper. Only zinc for infiltration.  
 2. Based on fewer than five data points (i.e., independent monitoring studies).  
 3. Infiltration practices only provide treatment when located within the soil profile. These removal values also include porous pavement, which is not on the list of approved water quality practices for CNMI and Guam.  
 4. Higher removal rates expected for dry swales.  
 5. While no data is available on the removal of bacteria for infiltration practices, it is generally accepted that if there is a good soil matrix, removal is expected to be high; while if there is little organic matter and a shallow soil profile over limestone, removal is likely to be poor.  
 N/A: Data not available  
 Removals represent median values from Winer (2000)

## 2.6 Step 6 - Community and Environmental

The last step assesses community and environmental factors involved in BMP selection. This matrix employs a comparative index approach. An open circle indicates that the BMP has a high benefit and a dark circle indicates that the particular BMP has a low benefit.

*Maintenance.* This column assesses the relative maintenance effort needed for a practice, in terms of three criteria: frequency of scheduled maintenance, chronic maintenance problems (such as clogging) and reported failure rates. It should be noted that all BMPs require routine inspection and maintenance.

*Affordability.* The BMPs are ranked according to their relative construction cost per impervious acre treated. These costs exclude design, land acquisition, and other costs.

*Community Acceptance.* This column assesses community acceptance, as measured by three factors: market and preference surveys, reported nuisance problems, and visual orientation (i.e., is it prominently located or is it in a discrete underground location). It should be noted that a low rank can often be improved by a better landscaping plan.

*Safety.* A comparative index that expresses the relative public safety of a BMP. An open circle indicates a reasonably safe BMP, while a darkened circle indicates deep pools may create potential public safety risks. The safety factor is included at this stage of the screening process because liability and safety are of paramount concern in many residential settings.

*Habitat.* BMPs are evaluated on their ability to provide wildlife or wetland habitat, assuming that an effort is made to landscape them appropriately. Objective criteria include size, water features, wetland features and vegetative cover of the BMP and its buffer.

**Table 2.6 BMP Selection Matrix 6-Community and Environmental**

BMP Group	BMP List	Ease Of Maintenance	Affordability	Community Acceptance	Safety	Habitat
Ponds	Micropool ED	◐	○	◐	◐	◐
	Wet Pond	○	○	○	●	○
	Wet ED Pond	○	○	○	●	○
Wetlands	Shallow Marsh	◐	◐	○	◐	○
	ED Wetland	◐	◐	◐	◐	○
	Pocket Wetland/Pond	●	○	◐	◐	●
Infiltration	Infiltration Trench/Chambers	●	◐	○	○	●
	Shallow I-Basin	●	◐	●	○	●
Filters	Sand Filter	●	●	◐	○	●
	Organic Filter	◐	●	○	○	●
	Bioretention	◐	◐	◐	○	◐
Open Channels	Dry Swale	◐	◐	○	○	●
	Wet Swale	○	○	◐	◐	◐
○ High    ◐ Medium    ● Low						





## ***3.0 Better Site Design and Non-Structural BMPs***

The purpose of this chapter is to provide guidance to plan for and implement Better Site Design practices for new development and redevelopment projects. While reducing the impacts from stormwater runoff may be achieved through both regulatory and non-regulatory techniques, this chapter focuses on the site-level planning and design tools available to the development community.

As research, technology, and information transfer have improved over recent years, alternative approaches are being sought by the public and regulatory boards to reduce the impacts of stormwater runoff from new development and redevelopment. Developers and designers also are seeking alternatives to expedite permitting processes, reduce construction costs, reduce long-term operation and maintenance costs, and increase property values.

### **3.1 Definition of Better Site Design**

What is “Better Site Design,” and how does it differ from “Conventional Design”? Better site design incorporates non-structural and natural approaches to new and redevelopment projects to reduce impacts on watersheds by conserving natural areas, reducing impervious cover and better integrating stormwater treatment. For the purposes of this chapter, Conventional Design can be viewed as the style of suburban development that has evolved over the past 50 years, which generally involves larger lot development, clearing and grading of significant portions of a site, wider streets and larger cul-de-sacs, large monolithic parking lots, enclosed drainage systems for stormwater conveyance, and large “hole-in-the-ground” detention basins.

### **3.2 Goals of Better Site Design**

The aim of better site design is to reduce the environmental impact “footprint” of the site while retaining and enhancing the owner/developer’s purpose and vision for the site. Many of the better site design concepts employ non-structural on-site treatment that can reduce the cost of infrastructure while maintaining or even increasing the value of the property relative to conventional designed developments. The goals of better site design include:

- Prevent stormwater impacts rather than having to mitigate for them;
- Manage stormwater (quantity and quality) as close to the source as possible and minimize the use of large or regional collection and conveyance;

- Preserve natural areas, native vegetation and reduce the impact on watershed hydrology;
- Use natural drainage pathways as a framework for site design;
- Utilize simple, non-structural methods for stormwater management that are lower cost and lower maintenance than structural controls; and
- Create a multifunctional landscape.

### **3.3 Benefits of Better Site Design**

The use of better site design can have a number of benefits that extend beyond improving water quality and stormwater runoff management that include:

- Reduced construction costs;
- Reduced long-term operation and maintenance costs;
- Increased property values;
- Easier compliance with wetland and other resource protection regulations;
- More open space for recreation;
- More pedestrian friendly neighborhoods;
- Protection of sensitive forests, wetlands, and habitats; and
- More aesthetically pleasing and naturally attractive landscape.

### **3.4 Better Site Design Planning Process**

Site design should be done in unison with the design and layout of stormwater infrastructure in attaining stormwater management and land use goals. The stormwater better site design process utilizes a three-step process as follows:

1. Avoid the Impacts – Preserve Natural Features and use Conservation Design Techniques.
2. Reduce the Impacts – Reduce Impervious Cover.
3. Manage the Impacts – Utilize Natural Features and Natural Low-Impact Techniques to Manage Stormwater.

The first step in the planning and design process is to avoid or minimize disturbance by preserving natural areas or strategically locating development based on the location of resource areas and physical conditions at a site. Once sensitive resource areas and site constraints have been avoided, the next step is to minimize the impact of land alteration by reducing impervious areas. Finally, for the areas that must be impervious, alternative and “natural-systems” stormwater management techniques are chosen as opposed to the more routine structural, “pipe-to-pond,” approach.

### **3.5 Better Site Design Categories**

Stormwater better site design practices and techniques covered in this chapter are grouped into the following three categories:

*Preservation of Natural Features and Conservation Design:* Preservation of natural features includes techniques to foster the identification and preservation of natural areas that can be used in the protection of water resources. Conservation Design includes laying out the elements of a development project in such a way that the site design takes advantage of a site's natural features, preserves the more sensitive areas, and identifies any site constraints and opportunities to prevent or reduce impacts.

*Reduction of Impervious Cover:* Reduction of Impervious Cover includes methods to reduce the amount of rooftops, parking lots, roadways, sidewalks and other surfaces that do not allow rainfall to infiltrate into the soil, in order to reduce the volume of stormwater runoff, increase groundwater recharge, and reduce pollutant loadings that are generated from a site.

*Utilization of Natural Features and Source Control for Stormwater Management:* Utilization of Natural Features for Stormwater Management includes design strategies that use natural features to help manage and mitigate runoff, rather than structural stormwater controls. Source Control for Stormwater Management includes elements to mitigate or manage stormwater in a natural or "lower-impact" manner.

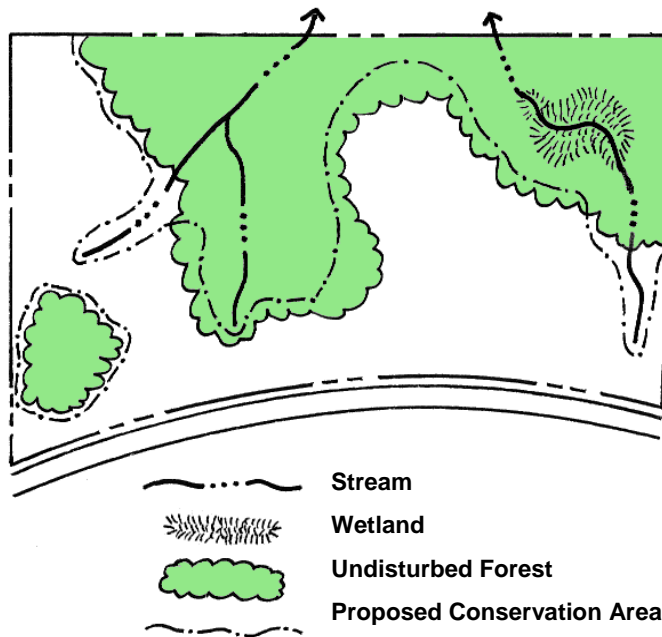
### 3.6 Better Site Design Best Management Practices

**Table 3.1** lists the specific better site design BMPs and techniques for each of the three categories, followed by a description of each practice.

**Table 3.1 Better Site Design General Categories and Specific BMPs**

<b>Preservation of Natural Features and Conservation Design</b>
<ol style="list-style-type: none"> <li>1. Preservation of Undisturbed Areas</li> <li>2. Preservation of Buffers</li> <li>3. Reduction of Clearing and Grading</li> <li>4. Locating Sites in Less Sensitive Areas</li> <li>5. Open Space Design</li> </ol>
<b>Reduction of Impervious Cover</b>
<ol style="list-style-type: none"> <li>6. Roadway Reduction</li> <li>7. Sidewalk Reduction</li> <li>8. Driveway Reduction</li> <li>9. Cul-de-Sac Reduction</li> <li>10. Building Footprint Reduction</li> <li>11. Parking Reduction</li> </ol>
<b>Utilization of Natural Features and Source Control for Stormwater Management</b>
<ol style="list-style-type: none"> <li>12. Vegetated Buffer/Filter Strips</li> <li>13. Open Vegetated Channels</li> <li>14. Bioretention and Rain Gardens</li> <li>15. Infiltration</li> <li>16. Rooftop Runoff Reduction Mitigation</li> <li>17. Stream Daylighting for Redevelopment Projects</li> <li>18. Tree Planting</li> </ol>

**Practice #1 – Preservation of Undisturbed Areas:** Important natural features and areas such as undisturbed forested and native vegetated areas, natural terrain, riparian corridors, wetlands and other important site features should be delineated and placed into permanent conservation areas.



**Figure 3.1 Example of Natural Resource Inventory Plan**

(Source: Georgia Stormwater Manual, 2001)

- Delineate and define natural conservation areas before performing site layout and design; and
  - Ensure that conservation areas and native vegetation are protected in an undisturbed state through the design, construction and occupancy stages. Ensure that vehicles, heavy equipment, and staging areas are prohibited in conservation/buffer areas.
- Practice #2 – Preservation of Buffers:** Naturally vegetated buffers should be defined, delineated and preserved along streams, rivers, shorelines, and wetlands.
- Delineate and preserve naturally vegetated riparian buffers (define the width, identify the target vegetation, designate methods to preserve the buffer indefinitely);
  - Ensure that buffers and native vegetation are protected throughout planning, design, construction and occupancy; and
  - Consult local planning authority for minimum buffer width and/or recommended width.

**Practice #3 – Reduction of Clearing and Grading:** Clearing and Grading of the site should be limited to the minimum amount needed for the development function, road access, and infrastructure (e.g., utilities, wastewater disposal, stormwater management). Site foot-printing should be used to disturb the smallest possible land area on a site.

- Restrict clearing to the minimum area required for building footprints, construction access, and safety setbacks;
- Establish limits of disturbance for all development activities;
- Use site foot-printing to minimize clearing and land disturbance;
- Limit site mass grading approach; and
- Use alternative site designs that use open-space or “cluster” developments.

**Practice #4 – Locating Sites in Less Sensitive Areas:** Development sites should be located to avoid sensitive resource areas such as floodplains, steep slopes, erodible soils, wetlands, mature

forests and critical habitat areas. Buildings, roadways, and parking areas should be located to fit the terrain and in areas that will create the least impact.

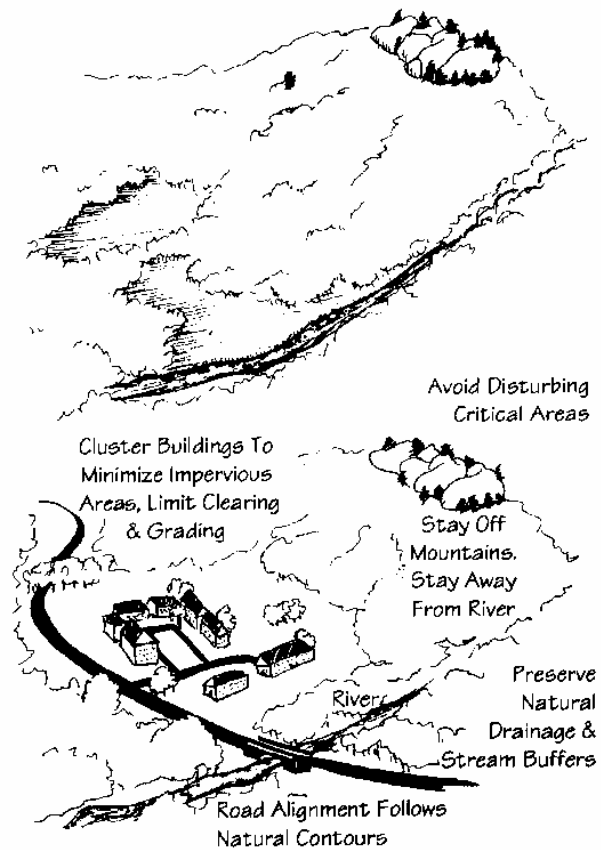
- Ensure all development activities do not encroach on designated floodplain and/or wetland areas;
- Avoid development on steep slope areas and minimize grading and flattening of hills and ridges;
- Leave areas of porous or highly erodible soils as undisturbed conservation areas;
- Develop roadway patterns to fit the site terrain and locate buildings and impervious surfaces away from steep slopes, drainageways and floodplains; and
- Locate site in areas that are less sensitive to disturbance or have a lower value in terms of hydrologic function.

**Practice #5 – Open Space Design:** Open space site designs (also referred to as conservation development or clustering) incorporate smaller lot sizes to reduce overall impervious cover while providing more undisturbed open space and protection of water resources.

- Use a site design which concentrates development and preserves open space and natural areas of the site;
- Locate the developed portion of the cluster areas in the least sensitive areas of the site (see practice #4); and
- Utilize reduced setbacks and frontages, and narrower right-of-way widths to design non-traditional lot layouts within the cluster.

**Practice #6 – Roadway Reduction:** Roadway lengths and widths should be minimized on a development site where possible to reduce overall imperviousness.

- Consider different site and road layouts that reduce overall street length;
- Minimize street width by using narrower street designs that are a function of land use, density and traffic demand; and
- Use smaller side yard setbacks to reduce total road length.



**Figure 3.2 Fit the design of a site to the terrain and natural features**



**Figure 3.3 Residential road in Saipan that seems much wider than necessary to accommodate residential traffic flow**

Practice #7 – Sidewalk Reduction: Sidewalk lengths and widths should be minimized on a development site where possible to reduce overall imperviousness.

- Locate sidewalks on only one side of the street;
- Provide common walkways linking pedestrian areas;
- Use alternative sidewalk and walkway surfaces (e.g., permeable pavers - **Figure 3.4**); and
- Shorten front setbacks to reduce walkway lengths.

Practice #8 – Driveway Reduction: Driveway lengths and widths should be minimized on a development site where possible to reduce overall imperviousness.

- Use shared driveways that connect two or more homes together;
- Use alternative driveway surfaces (e.g., permeable pavers - **Figure 3.4**); and
- Use smaller lot front building setbacks to reduce total driveway length.

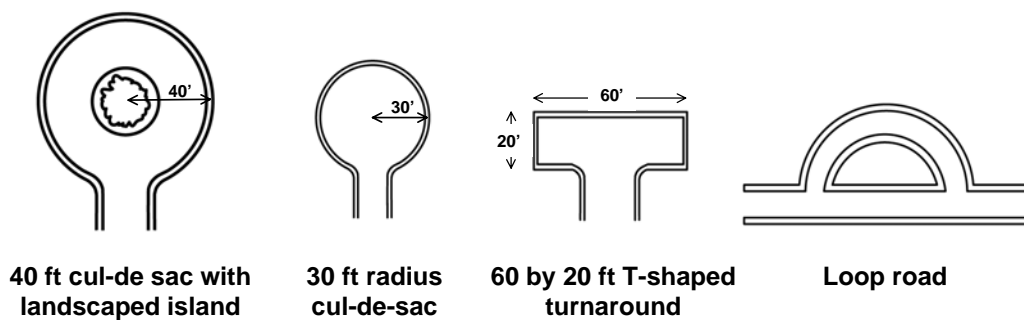


**Figure 3.4 Examples of Permeable Pavers**

(Source: MA EOE, 2005)

**Practice #9 – Cul-de-Sac Reduction:** Minimize the number of cul-de-sacs and incorporate landscaped areas to reduce their impervious cover. The radius of a cul-de-sac should be the minimum required to accommodate emergency and maintenance vehicles. Alternative turnarounds should also be considered.

- Reduce the radius of the turnaround bulb or consider alternative cul-de-sac design, such as “tee” turn-a-rounds or looping lanes;
- Apply site design strategies that minimize dead-end streets; and
- Create a pervious island or a stormwater bioretention area in the middle of the cul-de-sac to reduce impervious area.



**Figure 3.5 Turnaround Options for Residential Streets**

(Source: Adapted from Schueler, 1995)

**Practice #10 – Building Footprint Reduction:** The impervious footprint of residences and commercial buildings can be reduced by using alternate or taller buildings while maintaining the same floor to area ratio.

- Use alternate or taller building designs to reduce the impervious footprint of buildings;
- Consolidate functions and buildings or segment facilities to reduce footprints of structures; and
- Reduce directly connected impervious areas.

**Practice #11 – Parking Reduction:** Reduce the overall imperviousness associated with parking lots by eliminating unneeded spaces, providing some compact car spaces, minimizing stall dimensions, incorporating efficient parking lanes, utilizing multi-storied parking decks, and using porous paver surfaces or porous concrete in overflow parking areas where feasible.

- Reduce the number of un-needed parking spaces by examining minimum parking ratio requirements, and set a maximum number of spaces;
- Reduce the number of un-needed parking spaces by examining the site’s accessibility to mass transit;
- Minimize individual parking stall dimensions;
- Examine the traffic flow of the parking lot design to eliminate un-needed lanes/drive aisles;
- Consider parking structures and shared parking arrangements between non-competing uses;
- Use alternative porous surface for overflow areas, or in main parking areas if not a high traffic parking lot;
- Use landscaping or vegetated stormwater practices in parking lot islands; and
- Provide incentives for compact cars.

**Practice #12 – Vegetated Buffer/Filter Strips:** Undisturbed natural areas such as forested conservation areas and stream buffers, or vegetated filter strips, can be used to treat and control stormwater runoff from some areas of a development project.



**Figure 3.6 Use of a Grassed Filter Strip**

- Direct runoff towards buffers and undisturbed areas using sheet flow or a level spreader to ensure sheet flow;
- Utilize natural depressions for runoff storage;
- Direct runoff and nature of runoff (sheet flow versus shallow concentrated flow) to buffer/filter strip areas;
- Examine the slope, soils and vegetative cover of the buffer/filter strip; and
- Disconnect impervious areas to these areas.

**Practice #13 – Open Vegetated Channels:** The natural drainage paths of a site, or properly designed and constructed vegetated channels, can be used instead of constructing underground



storm sewers or concrete open channels. Where density, topography, soils, slope, and safety issues permit, vegetated open channels can be used in the street right-of-way to convey and treat stormwater runoff from roadways.

- Preserve natural flow paths in the site design;
- Direct runoff to natural drainage ways, ensuring that peak flows and velocities will not cause channel erosion;
- Use vegetated open channels (enhanced wet or dry swales or grass channels) in place of curb and gutter, and pipes, to convey and treat stormwater runoff; and
- Ensure runoff volumes and velocities provide adequate residence times and non-erosive conditions (i.e., use of check dams).

**Practice #14 – Bioretention and Rain Gardens:** Provide stormwater treatment for runoff from impervious surfaces using bioretention areas or rain gardens that can be integrated into required landscaping areas and traffic islands.

- Integrate bioretention into a parking lot or roadway design;
- Integrate bioretention, or rain gardens, into on-lot residential designs;
- Closely examine runoff volumes and velocities to ensure runoff enters bioretention in a distributed manner and in a non-erosive condition;
- Ensure the bioretention has proper pre-treatment;
- Carefully select the landscaping materials required; and
- Works well as a retrofit or in redevelopment projects.



**Figure 3.7 Dry Well**

(Source: MA EOE, 2005)

**Practice #15 – Infiltration:** Utilize infiltration trenches, basins, or leaching chambers to provide groundwater recharge, mimic existing hydrologic conditions, and reduce runoff and pollutant export. Permeable paving surfaces may also be used where site conditions are appropriate.

- May be used for roadway or parking impervious areas if adequate pre-treatment is provided;
- Rooftop runoff may discharge directly to drywells or infiltration chambers (**Figure 3.7**);
- The site must have soils with moderate to high infiltration capacities and must have adequate depth to groundwater;
- Certain sites (i.e., pollutant hotspots) require additional pretreatment prior to infiltration;
- Use porous pavers only in low traffic areas or for pedestrian walkways/plazas; and
- Poor soils may preclude aggressive infiltration.

**Practice #16 – Rooftop Runoff Reduction Mitigation:** Direct runoff from residential rooftop areas to pervious areas, lower-impact practices, or utilize “green roof” strategies to reduce rooftop runoff volumes and rates.

- Direct rooftop runoff to pervious areas such as yards, open channels, or vegetated areas;
- Direct rooftop runoff to lower-impact practices such as rain barrels, cisterns, drywells, rain gardens, or stormwater planters; and
- Utilize “green roofs” (specially designed vegetated rooftops) to reduce stormwater runoff from rooftops. No pesticides, fertilizers or other potential water pollutants should be used on green roofs.



**Figure 3.8 Rooftop runoff is directed to a landscaped area around this house in Saipan**

**Practice #17 – Stream Daylighting for Redevelopment Projects:** Daylight previously-culverted/piped streams to restore natural habitats, better attenuate runoff, and help reduce pollutant loads where feasible and practical.

- Daylighting should be considered when a culvert replacement is scheduled;
- Restore historic drainage patterns by removing closed drainage systems and constructing stabilized, vegetated streams;
- Carefully examine flooding potential, utility impacts and/or prior contaminated sites; and
- Consider runoff pretreatment and erosion potential of restored streams/rivers.

**Practice #18 – Tree Planting:** Plant or conserve trees at new or redevelopment sites to reduce stormwater runoff, increase nutrient uptake, provide bank stabilization, provide shading, and provide wildlife habitat. Trees can be used for applications such as landscaping, stormwater management practice areas, conservation areas and erosion and sediment control.

- Conserve existing trees during construction by performing an inventory of the existing forest and identifying trees to protect;
- Design the development with tree conservation in mind, protect trees during construction, and protect trees after construction;
- Plant trees at development sites by first selecting the planting sites and then evaluate and improve the planting sites. Trees should be planted in stormwater management practices and other open spaces; and
- Tree types and locations should be chosen to withstand the constraints of an urban setting.

The following case studies illustrate how better site design practices can be successfully incorporated into site planning. A comparison to a conventional design approach illustrates the opportunities presented by better site design practices to meet stormwater management criteria in addition to identifying the obstacles for implementing such practices.

#### *Medium Density Residential Subdivision Case Study*

A conventional residential subdivision design on a parcel is shown in **Figure 3.9a**. The entire parcel except for the subdivision amenity area (clubhouse and tennis courts) is used for lots. The entire site is cleared and mass graded, and no attempt is made to fit the road layout to the existing topography. Because of the clearing and grading, all of the existing tree cover and vegetation and topsoil are removed, dramatically altering both the natural hydrology and drainage of the site. The wide residential streets create unnecessary impervious cover and a curb-and-gutter system that carries stormwater flows to the storm sewer system. No provision for non-structural stormwater treatment is provided on the subdivision site.

A residential subdivision employing stormwater better site design practices is presented in **Figure 3.9b**. This subdivision configuration shows six (6) more lots than the conventional, while also preserving a quarter of the property as undisturbed open space and vegetation. The road layout is designed to fit the topography of the parcel, following the high points and ridgelines. The natural drainage patterns of the site are preserved and are utilized to provide natural stormwater treatment and conveyance. Narrower streets reduce impervious cover and open vegetated channels provide for treatment and conveyance of roadway and driveway runoff. Bioretention islands at the ends of cul-de-sacs also reduce impervious cover and provide stormwater treatment functions. When constructing and building homes, only the building envelopes of the individual lots are cleared and graded, further preserving the natural hydrology of the site.

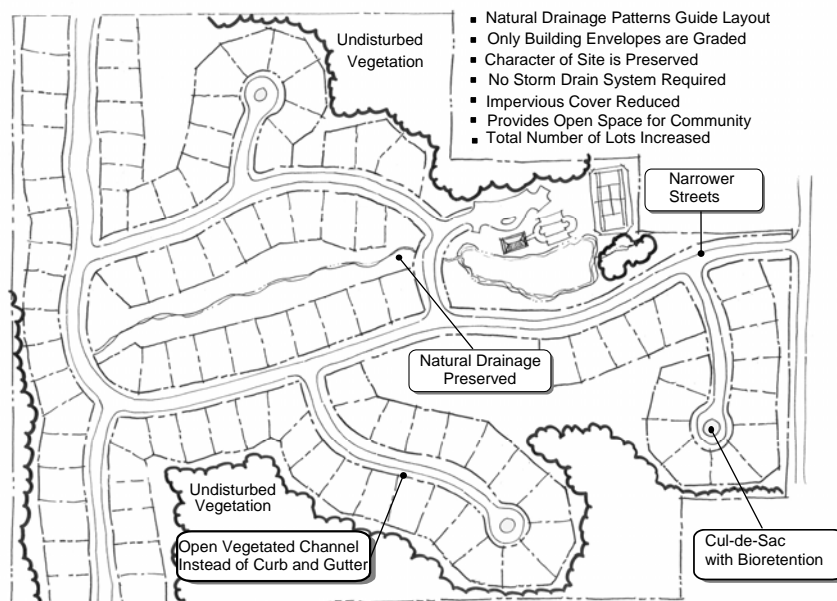
#### *Commercial Development Case Study*

**Figure 3.10a** shows a conventional commercial development containing a supermarket, drugstore, smaller shops and a restaurant on an adjacent lot. The majority of the parcel is a concentrated parking lot area. The only pervious area is a small replanted vegetation area acting as a buffer between the shopping center and adjacent land uses. Stormwater quality and quantity control are provided by a wet extended detention pond in the corner of the parcel.

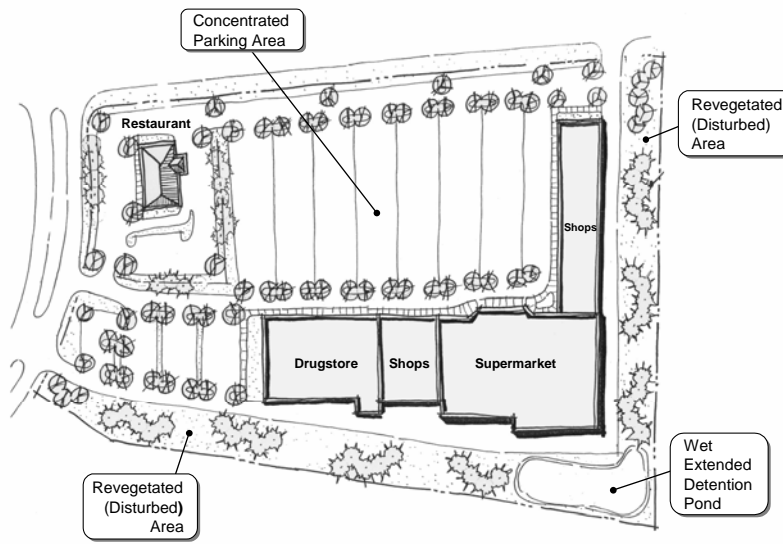
A better site design commercial development can be seen in **Figure 3.10b**. Here the same amount of retail space is dispersed on the property, providing more of an “urban-village” feel with pedestrian access between the buildings. The same number of parking spaces is broken up into separate areas, and bioretention areas for stormwater treatment are built into parking lot islands. A large bioretention area which serves as open green space is located at the main entrance to the shopping center. A larger undisturbed buffer has been preserved on the site. Because the bioretention areas and buffer provide water quality treatment, only a dry extended detention basin is needed for water quantity control.



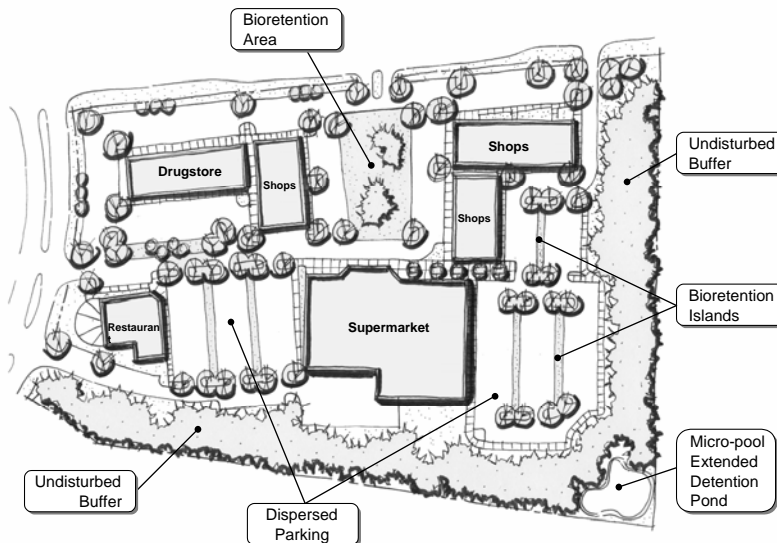
**Figure 3.9 Residential Subdivision - Conventional Design (above) and Better Site Design (below)**  
 (Source: Georgia Stormwater Manual, 2001)



**\*Number of lots actually increased in Better Site Design layout.**



**Figure 3.10 Commercial Development - Conventional Design (above) and Better Site Design (below).**  
 (Source: Georgia Stormwater Manual, 2001)



**\*Number of parking lots and amount of retail space are same in both designs.**

**<This page left blank intentionally>**



## 4.0 *Design Examples*

This chapter provides design examples based on hypothetical case studies located in both Guam and CNMI. Step-by-step design guidance for the following Best Management Practices (BMPs) are presented within four case studies:

### 4.1 *Case Study #1: Medium-Density Residential Site in Guam*

- Stormwater Wet Pond
- Dry Swale
- Infiltration Basin

### 4.2 *Case Study #2: Commercial Site in Guam*

- Bioretention with Grass Channel Pretreatment
- Bioretention with Filter Strip Pretreatment
- Sand Filter

### 4.3 *Case Study #3: Commercial Site in CNMI*

- Infiltration Trench with Oil/Grit Separator Pretreatment

### 4.4 *Case Study #4: Single-Family Residential Site in CNMI*

- Cistern and Drywell
- Rain Garden
- Permeable Pavers
- Swale

It should be noted that the case studies presented in this chapter are hypothetical even though they may be based upon actual development sites. Names and site characteristics have been revised as necessary to provide simplified and effective design examples. The design examples are for illustration purposes only for a particular type of stormwater practice, and do not necessarily include a comprehensive stormwater management design for the entire site, nor do they necessarily include examples of all the criteria required for the site. Sample calculations for all of the Unified Stormwater Sizing Criteria are presented in **Volume I, Section 2.2.4**. It should also be noted that for simplicity, the case studies presented often provide computed values or particular constraints that the designer would normally need to determine or research for an actual site design.

## 4.1 Case Study #1: Medium Density Residential Site in Guam

This case study represents a medium-density residential site located in Yigo, Guam. Mountain View Estates (see **Figure 4.1**) is a hypothetical subdivision consisting of approximately 180 ¼-acre lots, with approximately 28,000 linear feet of 48-ft wide residential roads. The total site consists of 44 acres with 69.1% impervious cover. Due to the site size and localized topographic features, the site area is divided into two catchments that drain to separate stormwater treatment practices. Catchment A drains to the southwest portion of the site and is comprised of 4.9 acres with 46.9% impervious cover. Catchment B drains to the southeast portion of the site and is comprised of 39.1 acres with 71.9% impervious cover.

On-site soils as determined by the NRCS soil maps are mostly Akina silty clay, classified as HSG “B”, as well as some Guam cobbly clay loam, classified as HSG “D”. The site is located in a small area of volcanic uplands in northern Guam, with the boundary between the volcanics/Akina soil type and the limestone/Guam soil type running through the lower portion of Catchment A. Three stormwater practice design examples are presented for this case study, consisting of a stormwater wet pond, a dry swale, and an infiltration basin. The data for the site is summarized in **Table 4.1**.

**Table 4.1 Base Data for Mountain View Estates**

	Hydrologic Data	
	Pre	Post
<b>Location:</b> Yigo, Guam		
<b>Drainage Area A</b>	<b>Area A</b>	
<b>Site Area:</b> 4.9 acres	<b>CN Value</b>	61      78
<b>Impervious Area:</b> 2.3 acres	<b>t<sub>c</sub></b>	0.26    0.23
<b>Drainage Area B</b>	<b>Area B</b>	
<b>Site Area:</b> 39.1 acres	<b>CN Value</b>	60      89
<b>Impervious Area:</b> 28.1 acres	<b>t<sub>c</sub></b>	0.46    0.20
<b>Soils Type:</b> Akina silty clay, “B” Guam cobbly clay loam, “D”		



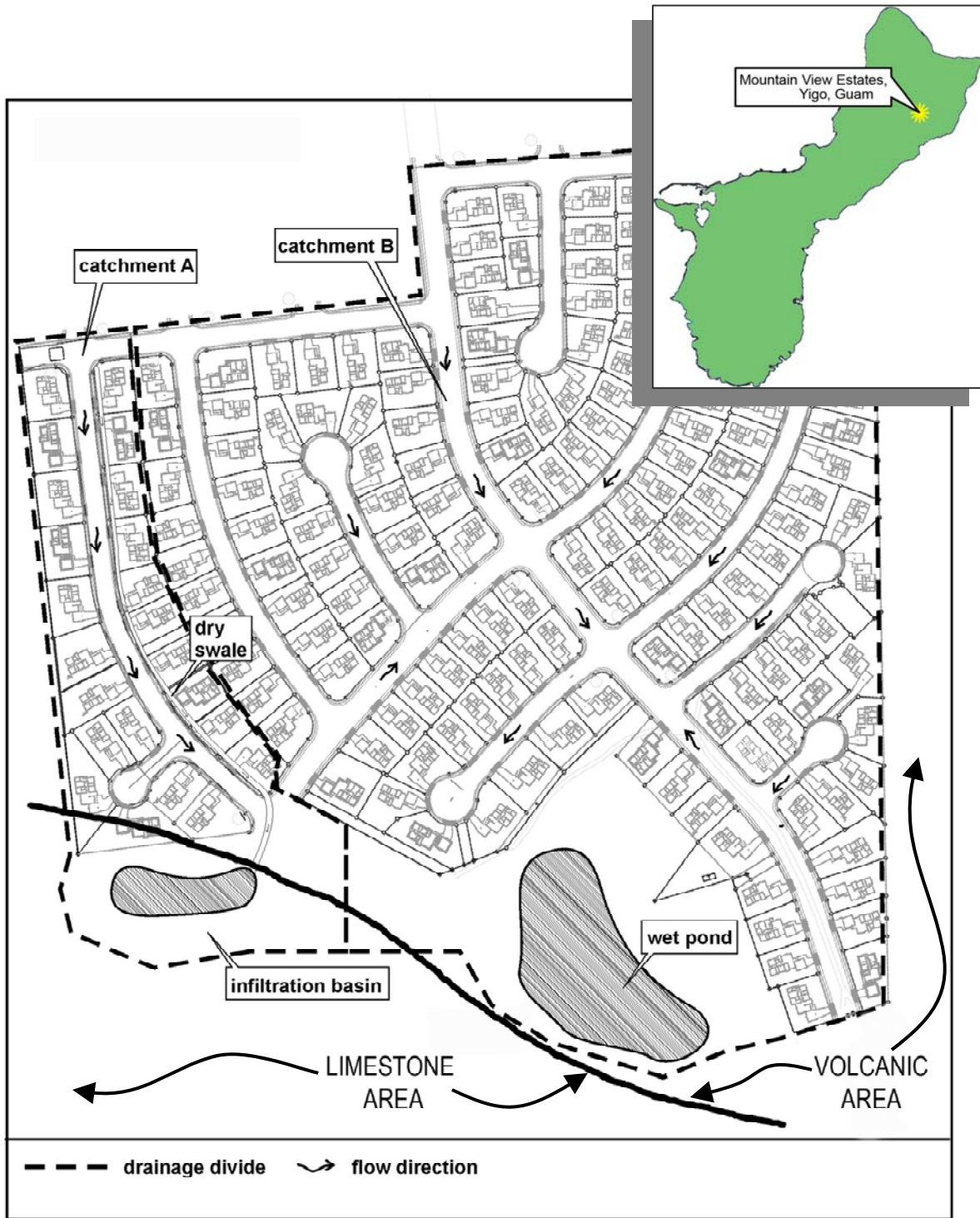


Figure 4.1 Medium Density Residential Site Plan in Guam

#### 4.1.1 Stormwater Wet Pond Design Example

The layout of the Mountain View Estates is shown in **Figure 4.1**. This is the same site used in **Section 4.1.2 and 4.1.3** (dry swale and infiltration basin design examples). Due to the site size and localized topographic features, the site area is divided into two catchments - this example focuses on the design of a stormwater wet pond associated with catchment area “B” of the Mountain View Estates residential subdivision (see **Figure 4.1**). This step-by-step example shows how the water quality volume, channel protection, and peak control requirements for this portion of the site will be met by the stormwater pond. In general, the primary function of wet ponds is to provide water quality treatment and storage volume for large storms. The recharge requirements for this site are being met by bioretention/rain gardens in each lot, which are not shown here.

#### Step 1: Compute preliminary runoff control volumes.

The volume requirements were determined in **Volume I, Section 2.2.4** (Sample Calculations). **Table 4.2** provides a summary of the storage requirements.

**Table 4.2 Summary of General Storage Requirements for Mountain View Estates, Catchment B**

Symbol	Category	Volume Required (ac-ft)	Notes
Re <sub>v</sub>	Recharge Volume	1.2	
WQ <sub>v</sub>	Water Quality Volume	1.9	Includes Re <sub>v</sub>
Cp <sub>v</sub>	Stream Protection	3.7	Average ED release rate is 1.87 cfs over 24 hours
Q <sub>p-25</sub>	Overbank Control	6.81	

#### Step 2: Determine if the development site and conditions are appropriate for the use of a stormwater pond.

The drainage area to the pond is 39.1 acres. Existing ground at the proposed pond outlet is 390.0 ft. Soil boring observations reveal that the seasonally high water table is at elevation 379.0 ft. The soil layer is 60 inches deep (Akina silty clay). The pond will discharge into an existing natural drainage channel.

#### Step 3: Confirm local design criteria and applicability.

There are no additional requirements for this site.

**Step 4: Determine pretreatment volume.**

Size wet forebay to treat 10% of the  $WQ_v$  as required in **Volume I, Section 3.2.4.1c**:

$$(0.1) (1.9 \text{ ac-ft}) = 0.2 \text{ ac-ft}$$

(forebay volume is included in  $WQ_v$  as part of permanent pool volume)

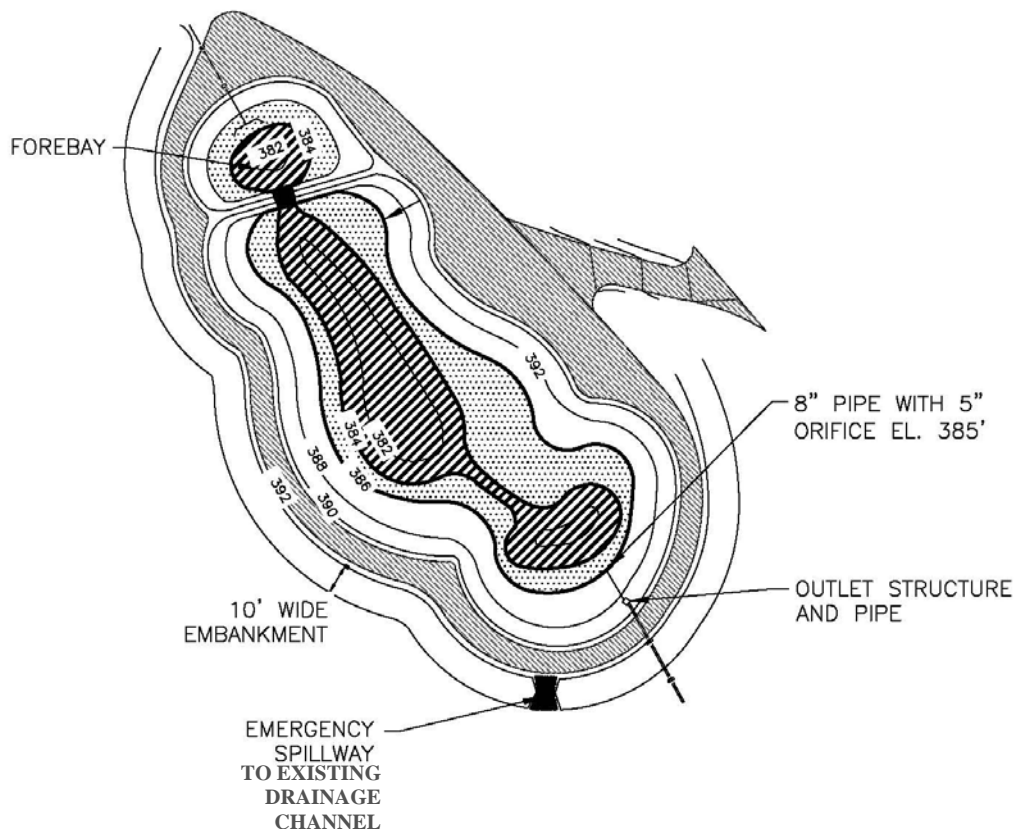
**Step 5: Determine permanent pool volume.**

Size permanent pool volume to contain at least 100% of  $WQ_v$  (minus recharge volume which is being handled upstream by bioretention/rain gardens in each lot):

$$1.9 - 1.2 = 0.7 \text{ ac-ft. (includes 0.2 ac-ft of forebay volume)}$$

**Step 6: Determine pond location and preliminary geometry. Conduct pond grading and determine storage available for  $WQ_v$  permanent pool.**

This step involves initially grading the pond (establishing contours) and determining the elevation-storage relationship for the pond. Storage must be provided for the permanent pool (including sediment forebay), 1-year storm, and 25-year storm. An elevation-storage table and curve is prepared using the average area method for computing volumes. A 2-ft berm is included around the edge of the pond. See **Figure 4.2** for pond grading and **Figure 4.3** for Elevation-Storage Data.

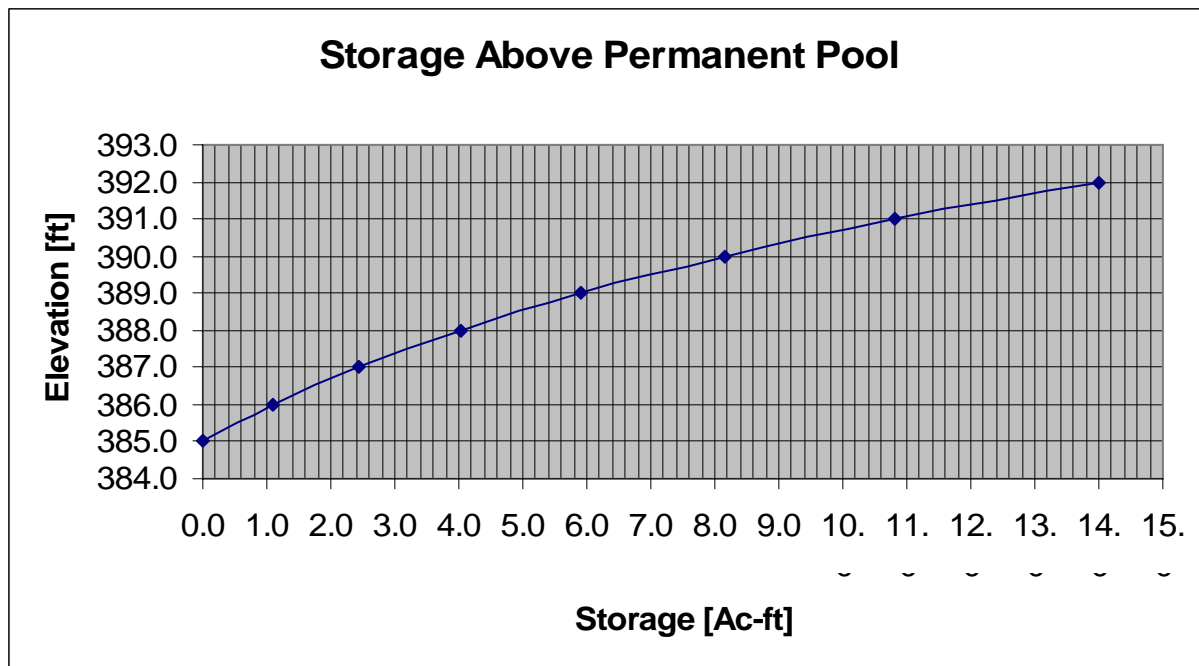


**Figure 4.2 Plan View of Pond Grading for Residential Site on Guam (Not to Scale)**

**Figure 4.3 Storage-Elevation Table/Curve for Pond Design**

Elevation ft	Area ft <sup>2</sup>	Average Area ft <sup>2</sup>	Depth ft	Volume ft <sup>3</sup>	Cumulative Volume ft <sup>3</sup>	Cumulative Volume ac-ft	Volume Above Permanent Pool ac-ft	Elevation ft
381.0	5468							381.0
382.0	6455	5962	1	5962	5962	0.14		382.0
383.0	7480	6968	1	6968	12929	0.30		383.0
384.0	12467	9974	1	9974	22903	0.53		384.0
385.0	13668	13068	1	13068	35970	0.83	0.00	385.0
386.0	54226	33947	1	33947	69917	1.61	1.08	386.0
387.0	64071	59149	1	59149	129066	2.96	2.44	387.0
388.0	74325	69198	1	69198	198264	4.55	4.03	388.0
389.0	88872	81599	1	81599	279862	6.42	5.90	389.0
390.0	106819	97846	1	97846	377708	8.67	8.15	390.0
391.0	126456	116638	1	116638	494345	11.35	10.82	391.0
392.0	150257	138357	1	138357	632702	14.52	14.00	392.0

← Perm. Pool Elev.



Set basic elevations for pond structures

- The pond bottom is set at elevation 381.0 ft.
- Provide gravity flow to allow for pond drain, set riser invert at 381.0 ft.
- Set barrel outlet elevation at 379.0 ft.

Set permanent pool water surface elevation

- Required permanent pool volume = 100% of  $WQ_v = 0.7$  ac-ft. From the elevation-storage table, read elevation 385.0 ft (0.83 ac-ft) – site can accommodate it and it allows for a safety factor for fine sediment accumulation – OK
- Set permanent pool wsel = 385.0 ft
- Forebay volume provided in single pool with volume = 0.2 ac-ft - OK

### Step 7: Compute release rate for $C_{pv}$ control and establish $C_{pv}$ elevation.

Set the  $C_{pv}$  pool elevation.

- Required  $C_{pv}$  storage = 3.7 ac-ft (see **Table 4.1**).
- From the elevation-storage table, read elevation 387.9 ft.
- Set  $C_{pv}$  wsel = 388.0 ft

Size  $C_{pv}$  orifice.

- Size to release average of 1.87 cfs.
  - Set invert of orifice at wsel = 385.0 ft
  - Head = (388.0 ft – 385.0 ft)/2 = 1.5 ft

Note: use average head between  $C_{pv}$  elevation and permanent pool

Use orifice equation to compute cross-sectional area and diameter.

- $Q = CA(2gh)^{0.5}$ , for  $h = 1.5$  ft
  - $A = 1.87 \text{ cfs} / [(0.6)((2)(32.2 \text{ ft/s}^2)(1.5\text{ft}))^{0.5}]$
  - $A = 0.114 \text{ ft}^2$ ,  $A = \pi d^2 / 4$ ;
  - dia. = 0.38 ft = 4.6 in
  - Use 8in pipe with 5in orifice plate to achieve equivalent diameter

Compute the stage-discharge equation for the 5in dia.  $C_{pv}$  orifice

- $Q_{C_{pv}} = CA(2gh)^{0.5} = (0.6) (0.14 \text{ ft}^2) [((2) (32.2\text{ft/s}^2))^{0.5}] (h^{0.5})$ ,
- $Q_{C_{pv}} = (0.66) (h^{0.5})$ , where:  $h = \text{wsel} - 385.21 \text{ ft}$

Note: head is measured from the WSEL to the center line of the orifice.

### Step 8: Calculate $Q_{p-25}$ (25-year storm) release rate and water surface elevation.

In order to calculate the 25-year release rate and water surface elevation, the designer must set up a stage-storage-discharge relationship for the control structure for the  $C_{pv}$  orifice plus the 25-year storm.

Develop basic data and information

- The 25-year pre-developed peak discharge = 122 cfs
- The post developed inflow = 182 cfs
- From previous estimate  $Q_{p-25} = 6.81$  ac-ft. Adding 15% to account for ED storage yields a preliminary volume of 7.83 ac-ft, say 7.85 ac-ft.
- From elevation-storage table (**Figure 4.3**), read elevation 389.9 ft, say 390.0 ft.

Size 25-year slot to release 122 cfs at a water surface elevation of 390.0 ft.

At wsel 390.0 ft:

- $C_{pv}$  orifice releases 1.87 cfs, therefore
- Allowable  $Q_{p-25} = 122 \text{ cfs} - 1.9 = 120.1 \text{ cfs}$ .
- Set weir crest elevation at wsel = 388.0 ft (this is max  $C_{pv}$  elevation)
- Max head = (390.0 ft – 388.0 ft) = 2.0 ft

- Use weir equation to compute slot length →  $Q = CLh^{3/2}$
- $L = 58.1 \text{ cfs} / (3.1) (2.0^{3/2}) = 13.7 \text{ ft}$

Use four (4) 4.0 ft x 2.0 ft slots for 25-year release (opening should be slightly larger than needed so as to have the barrel control before slot goes from weir flow to orifice flow).

Maximum  $Q = (3.1)(7.0)(2.0)^{3/2} = 140.29 \text{ cfs}$

Check orifice equation using cross-sectional area of opening

- $Q = CA(2gh)^{0.5}$ , for  $h = 1.0\text{ft}$  (For orifice equation,  $h$  is from midpoint of slot)
- $A = (16.0\text{ft}) (2.0\text{ft}) = 32.0 \text{ ft}^2$
- $Q = 0.6 (14.0 \text{ ft}^2) [(64.4)(1.0)]^{0.5} = 154.1 \text{ cfs} > 140.29 \text{ cfs}$ , so weir equation controls.
- $Q_{25} = (3.1) (16.0) h^{3/2}$ ,  $Q_{25} = (49.6) h^{3/2}$ , where  $h = \text{wsel} - 388.0 \text{ ft}$

Size barrel to release approximately 122 cfs at elevation 390.0 ft using approved pipe sizing method (e.g., culvert sizing software, NRCS pipe sizing equation). In this case, use a 42-in barrel for the outlet.

Complete stage-storage-discharge summary (**Table 4.3**) up to preliminary 25-year wsel (390.0 ft) and route 25-year post-developed condition inflow using computer software (e.g., HydroCAD, TR-55).

- Pond routing computes 25-year wsel at 390.2 ft with discharge = 119.07 cfs < 122 cfs, OK.

**Table 4.3 Stage-Storage-Discharge Summary for Pond Example**

Elevation ft	Storage ac-ft	Riser						42" Barrel		Total Discharge
		Cpv 5.0" eq. dia		High Stage Slot				Pipe		
		H ft	Q cfs	Orifice		Weir		H ft	Q cfs	
		H ft	Q cfs	H ft	Q cfs	H ft	Q cfs	H ft	Q cfs	Q cfs
385.0	0.00	0.0	0.00							0.00
386.0	1.08	0.8	0.59							0.59
387.0	2.44	1.8	0.88							0.88
388.0	4.03	2.8	1.10			0.0	0.0			1.10
389.0	5.90	3.8	1.28			1.0	49.6			50.88
390.0	8.15	4.8	1.44	1	154	2.0	140.3	9.0	116.9	116.89

Note: Adequate outfall protection must be provided in the form of a riprap channel, plunge pool, or combination to ensure non-erosive velocities.

The 25-year wsel is at 390.0 ft (see **Table 4.4** – TR-55 Results). Set the emergency spillway invert at elevation 391.0 ft (this allows for a foot of freeboard above the 25-yr wsel) and design according to spillway criteria in **Section 6.1**. This pond is considered an excavated pond rather than an embankment pond. “Token” or emergency spillways (those placed above the water elevation of the largest managed storm) must be a minimum 8 ft wide, 1 ft deep, with 2:1 side slopes.

**Table 4.5** provides a summary of the storage, stage, and discharge relationships determined for this design example.

**Table 4.4 Sample TR-55 Results from HydroCAD**

**residential** Type IA 24-hr 25-year Rainfall=20.00"  
 Prepared by Horsley Witten Group Page 5  
 HydroCAD® 7.00 s/n 001445 © 1986-2003 Applied Microcomputer Systems 4/4/2006

**Subcatchment CB: Post-development, Catchment B**

Runoff = 182.27 cfs @ 7.98 hrs, Volume= 60.571 af, Depth=18.59"

Runoff by SCS TR-20 method, UH=SCS, Time Span= 0.00-100.00 hrs, dt= 0.01 hrs  
 Type IA 24-hr 25-year Rainfall=20.00"

Area (ac)	CN	Description
28.100	98	Paved parking & roofs
11.000	69	50-75% Grass cover, Fair, HSG B
39.100	89	Weighted Average

Tc (min)	Length (feet)	Slope (ft/ft)	Velocity (ft/sec)	Capacity (cfs)	Description
5.5	50	0.0200	0.2		<b>Sheet Flow,</b> Grass: Dense n= 0.240 P2= 7.00"
0.8	50	0.0200	1.0		<b>Shallow Concentrated Flow,</b> Short Grass Pasture Kv= 7.0 fps
2.9	700	0.0100	4.0	2.19	<b>Circular Channel (pipe),</b> Diam= 10.0" Area= 0.5 sf Perim= 2.6' r= 0.21' n= 0.013
2.8	1,251	0.0200	7.4	9.14	<b>Circular Channel (pipe),</b> Diam= 15.0" Area= 1.2 sf Perim= 3.9' r= 0.31' n= 0.013
12.0	2,051	Total			

**Pond WP: Wet Pond**

Inflow Area = 39.100 ac, Inflow Depth = 18.59" for 25-year event  
 Inflow = 182.27 cfs @ 7.98 hrs, Volume= 60.571 af  
 Outflow = 119.07 cfs @ 8.24 hrs, Volume= 59.638 af, Atten= 35%, Lag= 15.8 min  
 Primary = 119.07 cfs @ 8.24 hrs, Volume= 59.638 af  
 Secondary = 0.00 cfs @ 0.00 hrs, Volume= 0.000 af

Routing by Stor-Ind method, Time Span= 0.00-100.00 hrs, dt= 0.01 hrs  
 Peak Elev= 390.0' @ 8.24 hrs Surf.Area= 112,415 sf Storage= 410,946 cf  
 Plug-Flow detention time= 223.8 min calculated for 59.632 af (98% of inflow)  
 Center-of-Mass det. time= 212.3 min ( 882.5 - 670.2 )

#	Invert	Avail.Storage	Storage Description
1	381.00'	563,523 cf	<b>Custom Stage Data (Prismatic)</b> Listed below

**Table 4.5 Summary of Controls Provided for Pond Example**

Control Element	Type/Size of Control	Storage Provided	Elevation	Discharge	Remarks
<i>Units</i>		<i>Acre-feet</i>	<i>ft</i>	<i>cfs</i>	
Permanent Pool		0.83	385.0	0	part of $WQ_v$
Forebay	submerged berm	0.2	385.0	0	included in permanent pool vol.
Channel Protection ( $C_p$ )	8in pipe with 5in orifice plate	4.03	388.0	1.87	volume above perm. pool, discharge is average release rate over 24 hours
Overbank Protection ( $Q_{p-25}$ )	Four 4ft x 2ft slots on a 5ft x 5ft riser, 42in barrel.	8.15	390.0	122	volume above perm. pool
Emergency Spillway (storms > $Q_{p-25}$ )	Grass channel 8ft bottom width, 1ft deep, 2:1 side slopes	10.82	391.0	130	volume above perm. pool

See **Figure 4.4** for the profile of the principal spillway.



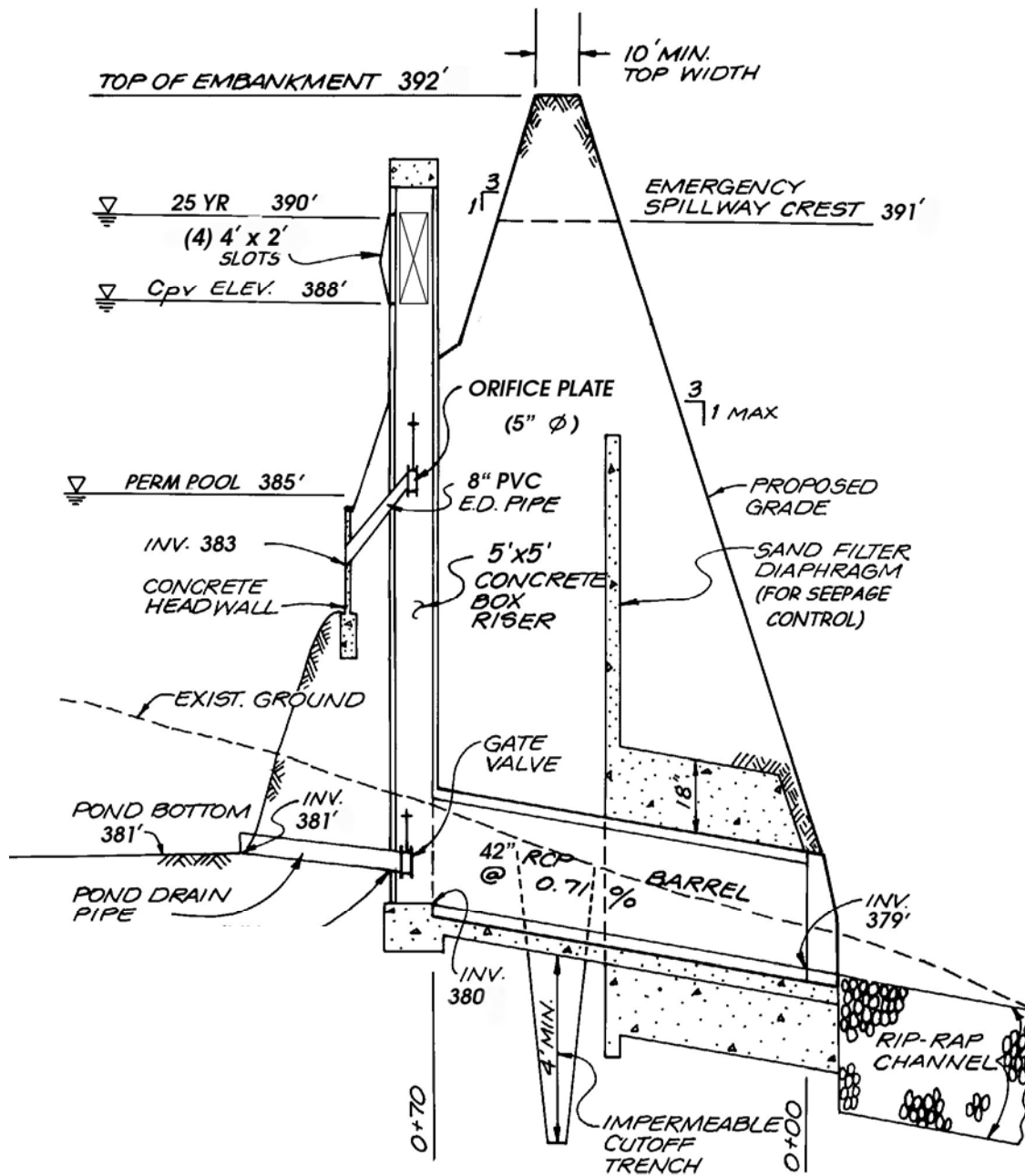


Figure 4.4 Profile of Principal Spillway

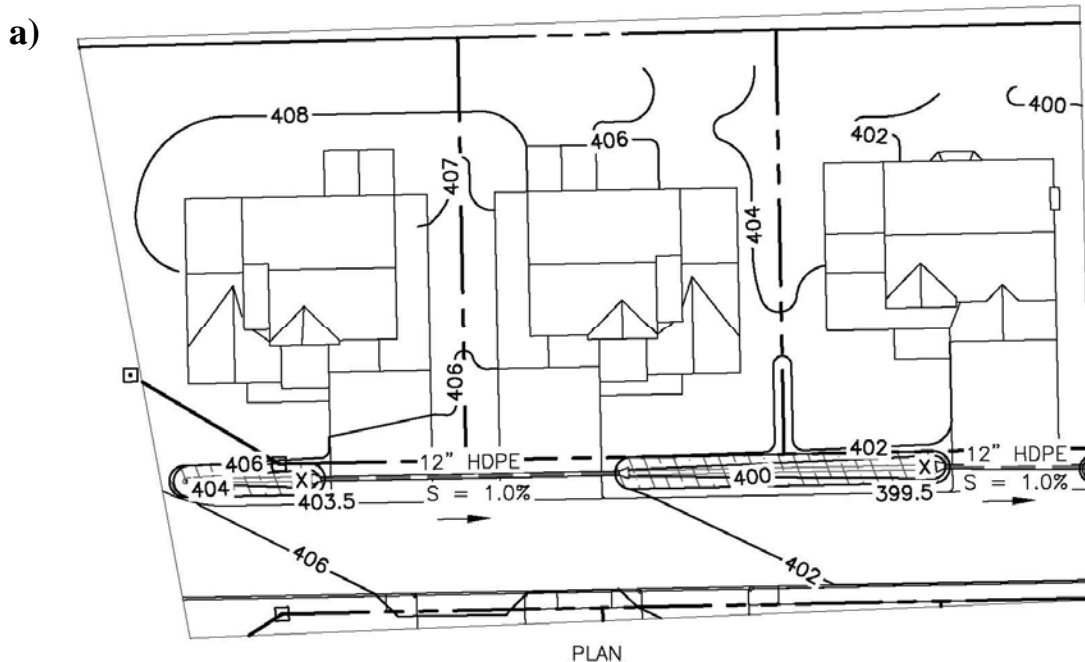
**<This page left blank intentionally>**

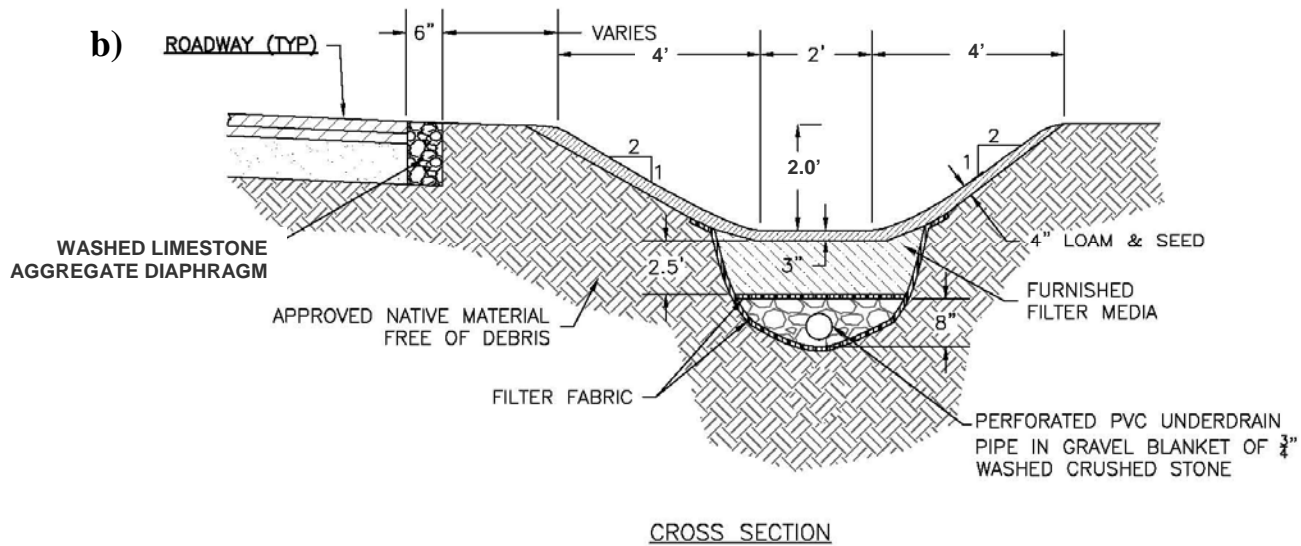
### 4.1.2 Dry Swale Design Example

This example focuses on the design of a dry swale associated with catchment area “A” of the Mountain View Estates residential subdivision (see **Figure 4.1**). This step-by-step example shows how the water quality volume requirements for this portion of the site will be met by the dry swale. In general, the primary function of dry swales is to provide water quality treatment and convey larger storms in a non-erosive condition. For this example, the post-development, 1-year and 2-year peak discharges are computed to check for non-erosive flows and to ensure that the channel has capacity to convey the 2-year event. The recharge, channel protection, and peak control requirements for this catchment area will be met after discharge from the swale by use of an infiltration basin, which will be presented as a separate design example in **Section 4.1.3**.

**Table 4.6 Base Data for Mountain View Estates – Dry Swale**

<u>Base Data</u>	<u>Hydrologic Data</u>	
Location: Yigo, Guam		
Total Drainage Area (A) = 4.9 ac		
Measured Impervious Area=2.3 ac; or $I=2.3/4.9=46.9\%$		
Site Soils Types: 85% “B,” 15% “D”		
	<u>Pre</u>	<u>Post</u>
	CN	78
	$t_c$ (hr)	0.23





**Figure 4.5 Plan View (a) and Cross-Section (b) of Dry Swale**

**Step 1: Determine if the development site and conditions are appropriate for the use of a dry swale.**

The proposed road grade in the vicinity of the dry swale is approximately 3.0%. Soils are modestly to well drained. There is sufficient area to accommodate the dry swale within the roadside right of way.

**Step 2: Confirm local design criteria and applicability.**

There are no additional requirements for this site.

**Step 3: Compute the recharge and water quality volume.**

The impervious portion of this site is located in the volcanic region of the island (see **Figure 4.1** and **Volume I, Figure 2.1**) in “B” soils, so use  $F = 0.5$  multiplied by the impervious area.

$$\begin{aligned} Re_v &= [(F)(I)(A)] / 12 \\ &= [(0.5)(0.469)(4.9 \text{ ac})] (1\text{ft}/12\text{in}) \\ &= \underline{0.096 \text{ ac-ft}} \end{aligned}$$

This site is in the S2 area on Guam, which falls under the 80% capture rule with 0.8 inches for moderate quality resource areas **Volume I, Figure 2.1**.

$$\begin{aligned} WQ_v &= [(P)(I)(A)] / 12 \\ &= [(0.8\text{in})(0.469)(4.9 \text{ ac})] (1\text{ft}/12\text{in}) \\ &= \underline{0.153 \text{ ac-ft} = 6,674 \text{ ft}^3} \end{aligned}$$

$Re_v$  is less than  $WQ_v$ , so 100% of the recharge volume can be included within the  $WQ_v$ . This dry swale design will have an “open bottom” (i.e., no impermeable liner (**Figure 4.5**)) to allow groundwater recharge, but there is also an underdrain to convey water downstream to an infiltration basin where the recharge requirement will be met (see **Section 4.1.3**).

#### Step 4: Determine size of dry swale area.

The dry swale treats the  $WQ_v$  by filtering it through a filter bed. The following equation (also used for filtering BMPs) is used to size the surface area of the dry swale, given a maximum depth of 18 inches as required in **Volume I, Section 3.2.4.5d**.

$$A_f = (WQ_v) (d_f) / [(k) (h_f + d_f) (t_f)]$$

Where:

- $A_f$  = surface area of filter bed ( $ft^2$ )
- $WQ_v$  = Water quality volume ( $ft^3$ )
- $d_f$  = filter bed depth (ft) (recommended 2.5 ft from **Volume I, Figure 3.13**)
- $k$  = filter media coefficient of permeability (ft/day) (use same media as bioretention)
- $h_f$  = average height of water above filter bed (ft) (i.e.,  $\frac{1}{2}$  the max depth)
- $t_f$  = design filter bed drain time (days) (2 days is recommended)

$$A_f = (6,674 \text{ ft}^3) (2.5 \text{ ft}) / [(1 \text{ ft/day}) (0.75 \text{ ft} + 2.5 \text{ ft}) (2 \text{ days})]$$

(With  $k = 1 \text{ ft/day}$ ,  $h_f = 0.75 \text{ ft}$ ,  $t_f = 2 \text{ days}$ )

$$A_f = \underline{2,567 \text{ ft}^2}$$

#### Step 5: Size a channel and compute the required length to store the water quality volume.

Provide bottom width, depth, length, and slope necessary to store  $WQ_v$  with a maximum of 18 inches of ponding (as required in **Volume I, Section 3.2.4.5d**).

Assume a trapezoidal channel with a maximum  $WQ_v$  depth of 18 inches. Per the site plan, there is approximately 650 ft available for the swale along the road, not including driveways where there will be culverts connecting the swale. The outlet of the swale will be at the proposed infiltration basin shown in **Section 4.1.3**. The existing uphill invert is 408.5 ft, and the infiltration basin invert is 391.0 ft.

$$\text{Slope} = (408.5 \text{ ft} - 391.0 \text{ ft}) / 650 \text{ ft} = 0.0199 = 2.7\%$$

Minimum slope 1.0% and maximum slope 4.0%, OK

Side slopes = 2:1 (given the space restraints of this development, use 2:1 slopes. For a better site design, the width of the roads could be decreased, which would decrease total runoff and increase available space for BMPs. This would allow shallower side slopes, which can be safer in residential areas, can reduce amount of erosion during slope stabilization, and can ease maintenance requirements, e.g., mowing. See **Chapter 3** for more information on this topic).

For a surface area of  $A_f = 2,567 \text{ ft}^2$  and a  $L = 650 \text{ ft}$ , the  $WQ_v$  top width needs to be  $(2,567 \text{ ft}^2 / 650 \text{ ft}) = 3.95 \text{ ft}$ . For a  $WQ_v$  average depth of 9 inches (0.75 ft) and 2:1 side slopes, compute a bottom width of  $(3.95 \text{ ft}) - [2 * (2) (0.75 \text{ ft})] = 0.95 \text{ ft}$ . A minimum bottom width of 2 ft is required according to **Volume I, Section 3.2.4.5d**. Actual average depth is  $(3.95 \text{ ft} - 2.0 \text{ ft}) / (2) * (0.5) = 0.49 \text{ ft} =$  approximately 6.0 inches – thus, the max depth will be 12 inches.

Compute number of check dams (or similar structure) required to detain  $WQ_v$ . For a swale 650 ft long @ 2.7% slope, max depth of 12 inches (1 ft), place check dams at:  $1 \text{ ft} / 0.027 = 37 \text{ ft}$  so  $(650 \text{ ft} / 37 \text{ ft}) = 18$  are required. Note, driveway culverts can be utilized to create the 12-inch max ponding depth.

**Step 6: Check the velocity of the 1-year storm and the hydraulic capacity of the 2-year storm.**

- Develop Site Hydrologic Input Parameters and Perform Preliminary Hydrologic Calculations (see **Table 4.5**).

Note: For this design example, the 1-year storm is used to check the channel geometry for non-erosive conditions, and the 2-year storm is used to check the conveyance capacity of the channel. Any hydrologic model using SCS procedures, such as TR-20, HEC-HMS, or HEC-1, can be used to perform preliminary hydrologic calculations. In this example, TR-55 was used to compute these values (see **Table 4.5**).

**Table 4.7 Mountain View Estates “A” Post-Developed - TR-55 Output for 1- and 2-year storm events**

<b>PEAK DISCHARGE SUMMARY</b>				
<b>JOB:</b> Mountain View Estates -				
<b>DRAINAGE AREA NAME:</b> POST DEVELOPMENT				
<b>COVER DESCRIPTION</b>	<b>SOIL NAME</b>	<b>GROUP A,B,C,D?</b>	<b>CN from TABLE 2-2</b>	<b>AREA (In acres)</b>
Grass	Akina silty clay	B	61	2.40 Ac.
Grass	Guam cobbly clay loam	D	80	0.20 Ac.
Impervious (roads, roofs, driveways)	Akina silty clay	B/D	98	2.30 Ac.
<b>AREA SUBTOTALS:</b>				<b>4.90 Ac.</b>
<b>Time of Concentration</b>	<b>Surface Cover</b>	<b>Manning 'n' Pipe Diameter</b>	<b>Flow Length Avg Velocity</b>	<b>Slope Tt (Hrs)</b>
2-Yr 24 Hr Rainfall = 7.0 In				
<b>Sheet Flow</b>	dense grass	'n'=0.24	50 Ft.	3.00% 0.08 Hrs
<b>Shallow Flow</b>	Short Grass Pasture		50 Ft. 7.00 F.P.S.	2.00% 0.01 Hrs.
<b>Channel Flow</b>		'n'=0.130	1080 Ft.	2.00% 0.14 Hrs.
<b>Total Area in Acres =</b>	<b>4.90 Ac.</b>	<b>Total Sheet Flow=</b>	<b>Total Shallow Flow=</b>	<b>Total Channel Flow=</b>
<b>Weighted CN =</b>	<b>79</b>			
<b>Time Of Concentration =</b>	<b>0.23 Hrs.</b>			
<b>RAINFALL TYPE IA</b>				
<b>STORM</b>	<b>Precipitation (P) inches</b>	<b>Runoff (Q)</b>	<b>Qp, PEAK DISCHARGE</b>	<b>TOTAL STORM Volumes</b>
<b>1 Year</b>	<b>3.5 In.</b>	<b>1.6 In.</b>	<b>1.7 CFS</b>	27,926 Cu. Ft.
<b>2 Year</b>	<b>7.0 In.</b>	<b>4.6 In.</b>	<b>5.6 CFS</b>	81,464 Cu. Ft.

Check to ensure non-erosive velocity for 1-year storm:

Roadway slope = 2.0%, check velocity and depth for the following parameters:

$Q_{1\text{-year}} = 1.7 \text{ cfs}$

Bottom width = 3.95 ft (top width of  $WQ_v$ )

Side slopes = 2:1

Longitudinal slope = 2.7%

Manning’s roughness coefficient (n) = 0.04

Using Manning’s equation for a trapezoid channel:

$$Q = (a) (v) = (a) [1.49/n (R)^{2/3} (S)^{1/2}]; a = bd + zd^2; R = a / (b + 2d\sqrt{z^2 + 1})$$

where  $v$  = velocity (ft/s)

$n$  = Manning's roughness coefficient,

$R$  = hydraulic radius (ft)

$a$  = cross sectional area (ft<sup>2</sup>)

$S$  = channel longitudinal slope

$b$  = bottom width (ft)

$d$  = depth of water (ft)

$z$  = side slope (z:1)

*Solve for depth and velocity.*

Results:

$$a = (3.95 * d) + 2(d * d) = 3.95d + 2d^2$$

$$R = (3.95d + 2d^2) / (3.95 + 2d\sqrt{5}) = (3.95d + 2d^2) / (3.95 + 4.47d)$$

$$Q = (3.95d + 2d^2) [1.49/0.04 * ((3.95d + 2d^2) / (3.95 + 4.47d))^{2/3} * 0.027^{1/2}]$$

### Depth

Due to complexity of equation, solve for  $d$  by trial and error. First, choose a depth that seems reasonable and solve for  $Q$ . Repeat until the solution for  $Q$  is equal to  $Q_{1\text{-year}}$  (1.7 cfs).

Spreadsheets can be set up to help streamline this process, or an open channel model can be used.

Trial 1. Try a depth of 0.5 ft.

$$a = 3.95(0.5) + 2(0.5)^2 = 2.48 \text{ ft}^2$$

$$R = 2.48 \text{ ft}^2 / (3.95 + 4.47(0.5)) = 0.4 \text{ ft}$$

$$Q = 2.48 \text{ ft}^2 [1.49/0.04 * (0.4 \text{ ft})^{2/3} * 0.027^{1/2}] = 8.24 \text{ cfs} > Q_{1\text{-year}}, \text{ so try a smaller depth.}$$

Trial 2. Try a depth of 0.3 ft.

$$a = 3.95(0.3) + 2(0.3)^2 = 1.37 \text{ ft}^2$$

$$R = 1.37 \text{ ft}^2 / (3.95 + 4.47(0.3)) = 0.256 \text{ ft}$$

$$Q = 1.37 \text{ ft}^2 [1.49/0.04 * (0.256 \text{ ft})^{2/3} * 0.027^{1/2}] = 3.38 \text{ cfs} > Q_{1\text{-year}}, \text{ so try a smaller depth.}$$

Trial 3. Try a depth of 0.2 ft

$$a = 3.95(0.2) + 2(0.2)^2 = 0.87 \text{ ft}^2$$

$$R = 0.87 \text{ ft}^2 / (3.95 + 4.47(0.2)) = 0.18 \text{ ft}$$

$$Q = 0.87 \text{ ft}^2 [1.49/0.04 * (0.18 \text{ ft})^{2/3} * 0.027^{1/2}] = 1.7 \text{ cfs} = Q_{1\text{-year}}$$

Thus, depth = 0.2 ft (provide at least 0.2 ft above top of check dams to accommodate this storm).

### Velocity

$$v = Q/a$$

$$v = 1.7 \text{ cfs} / 0.87 \text{ ft}^2 = 1.95 \text{ ft/s} \text{ (} v \text{ is less than 5.0 ft/s, OK)}$$

Check to ensure adequate capacity for 2-year storm:



From hydrology information, the 2-year flow is 5.6 cfs. Compute depth and provide an additional 0.5 ft of freeboard above 2-year flow.

Roadway slope = 2.0%, depth for the following parameters:

$$Q_{2\text{-year}} = 5.6 \text{ cfs}$$

$$\text{Bottom width} = 3.95 \text{ ft (top width of } WQ_v)$$

$$\text{Side slopes} = 2:1$$

$$\text{Longitudinal slope} = 2.7\%$$

$$\text{Manning's Coeff.} = 0.04$$

Solve for depth using Manning's equation and trial and error method shown above. Using a depth of 0.5 ft in Trial 1 above gave a solution of  $Q = 8.24$  cfs; thus, we know the depth for the 2-year storm is less than 0.5 ft.

Try a depth of 0.4 ft:

$$a = 3.95(0.4) + 2(0.4)^2 = 1.9 \text{ ft}^2$$

$$R = 1.9 \text{ ft}^2 / (3.95 + 4.47(0.4)) = 0.33 \text{ ft}$$

$$Q = 1.9 \text{ ft}^2 [1.49/0.04 * (0.33 \text{ ft})^{2/3} * 0.027^{1/2}] = 5.6 \text{ cfs} = Q_{2\text{-year}}$$

Results:

Depth = 0.4 ft. Provide 0.4 ft plus additional 0.5 ft of freeboard above checkdams. Total swale depth = 1.0 ft + 0.4 ft + 0.5 ft = 1.9 ft for a total top width of 9.6 ft.

### Step 7: Set design elevations and dimensions.

$WQ_v$ : depth = 1.0 ft (Height of Checkdam)

1-year:  $v = 1.9 \text{ ft/s}$ , depth\* = 1.0 ft + 0.2 ft = 1.2 ft

2-year: depth\* = 1.0 ft + 0.4 ft = 1.4 ft

set freeboard equal to 6 inches above 2-year depth = 1.4 ft + 0.5 ft = 1.9 ft.

Round off to  $d = 2.0$  ft, top width = 10 ft (see detail).

\*Note: Depth is calculated in the swale at a checkdam location. While in most cases the  $WQ_v$  ponded behind a checkdam will infiltrate through the filter media before the next storm event, the design should be conservative and allow for back-to-back rainfall events. Thus, for this example, the calculated 1-year storm depth is added to the height of the checkdam with the conservative assumption that water is ponded up to that level.

### Step 8: Design pretreatment.

Pretreat with grassed side slopes and washed, rounded limestone aggregate diaphragm (curtain drain).

Since runoff is not entering the swale directly from a concentrated inflow point (i.e., a pipe), no formal pretreatment chamber is required. Instead, pretreatment is provided by a washed, rounded limestone aggregate diaphragm (running parallel to the roadway shoulder) and the grass slopes leading to the edge of the channel (see **Figure 4.1**).

**Step 9: Choose vegetation for the channel.**

Choose vegetation based on factors such as resistance to erosion, resistance to drought and inundation, cost, aesthetics, maintenance, etc.

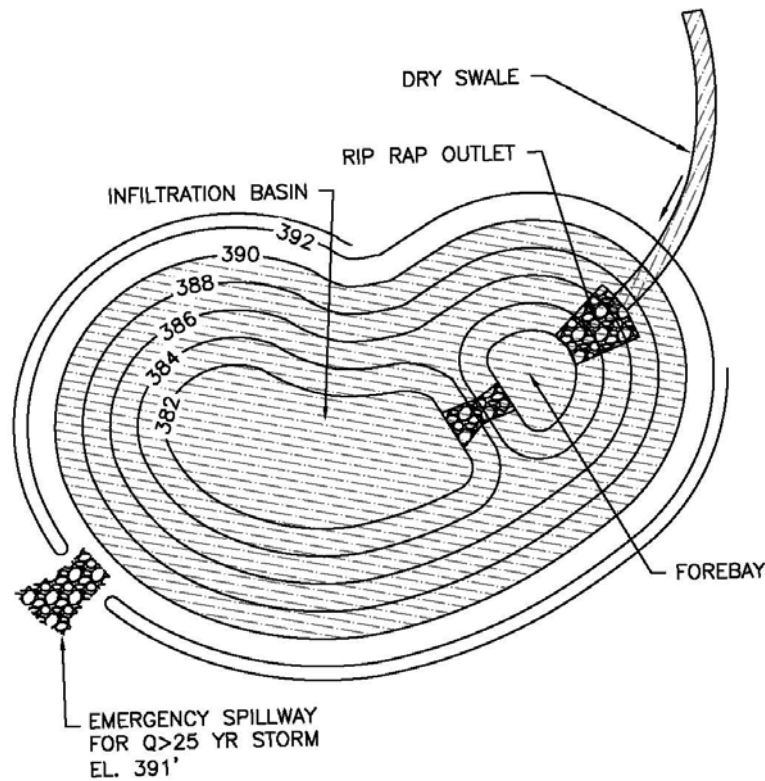
Based on the project slope range (0-5%), and 1-year velocity equal to approximately 2.0 ft/s, choose appropriate grass for channel (moist to well drained soils, higher permissible velocities, and good establishment rate). See local NRCS office for guidance.

### 4.1.3 Infiltration Basin Design Example

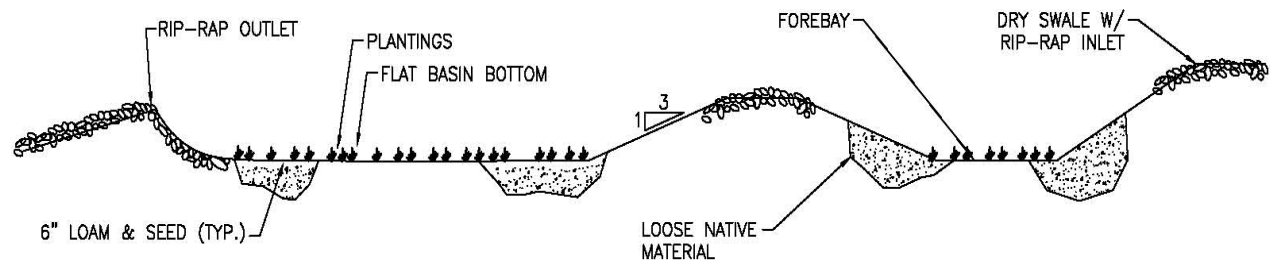
This example focuses on the design of an infiltration basin associated with catchment area “A” of the Mountain View Estates residential subdivision (see **Figure 4.1**). This step-by-step example shows how the recharge, channel protection and peak control requirements for this portion of the site will be met by the infiltration basin. An infiltration basin was chosen because the southwestern portion of the site is dominated by limestone geology, as shown on the geologic map (**Volume I, Figure 2.1**) and verified by geotechnical investigation. Groundwater was found at an elevation of 379 ft, just above the interface with the volcanics. The overflow from the basin will discharge into an existing sinkhole downgrade from the site. The water quality volume for this catchment area will be met prior to discharge to the infiltration basin by use of a dry swale, which is presented as a separate design example in **Section 4.1.2**.

**Table 4.8 Base Data for Mountain View Estates – Infiltration Basin**

<u>Base Data</u>	<u>Hydrologic Data</u>	
Location: Yigo, Guam		
Total Drainage Area (A) = 4.9		
Measured Impervious Area=2.3 ac; or $I = 2.3/4.9 = 46.9\%$	CN	<u>Pre</u> <u>Post</u>
Site Soils Types: 85% “B,” 15% “D”	$t_c$ (hr)	61   78
		0.26   0.23



**Figure 4.6 Plan View of Infiltration Basin**



**Figure 4.7 Cross-Section of Infiltration Basin**

**Step 1: Compute the  $Re_v$  and the  $Q_{p-25}$  Volume using the Unified Stormwater Sizing Criteria**

The western edge of this site is located in the limestone area of northern Guam where the soil profile is very shallow (~8 inches) with the highly pervious limestone bedrock underneath. Due to these conditions, an infiltration basin is an appropriate practice to be used to meet the recharge and volume requirements of the site since the water quality requirements are met by the dry swale in **Section 4.1.2**. The basin will be sized to infiltrate the  $Q_{p-25}$  volume (the entire  $Cp_v$  will be infiltrated as a result) with 1 ft of freeboard. The overflow from storms greater than the 25-year storm will be discharged off-site by means of an emergency spillway into a down-gradient sinkhole, where it can be shown that the overflow will not cause damage to neighboring houses or structures.

Even though the basin will be located in the limestone area, the impervious portion of this site is located in the volcanic region of the island (**Volume I, Figure 2.1**) in “B” soils, so use  $F = 0.5$  multiplied by the impervious area.

$$\begin{aligned}
 Re_v &= [(F) (I) (A)] / 12 \\
 &= [(0.5) (0.469) (4.9 \text{ ac})] (1\text{ft}/12\text{in}) \\
 &= \underline{0.096 \text{ ac-ft}}
 \end{aligned}$$

The  $Q_{p-25}$  volume was determined with a TR-55 computer model, with results shown in **Table 4.9** below.  $Q_{p-25} = 6.93 \text{ ac-ft}$ . The  $Re_v$  is included in the  $Q_{p-25}$  volume that will be infiltrated.

**Table 4.8 Mountain View Estates “A” Post-Developed - TR-55 Output for 1- and 25-year storm events**

<b>PEAK DISCHARGE SUMMARY</b>				
<b>JOB:</b> Mountain View Estates -				
<b>DRAINAGE AREA NAME:</b> POST DEVELOPMENT				
<b>COVER DESCRIPTION</b>	<b>SOIL NAME</b>	<b>GROUP A,B,C,D?</b>	<b>CN from TABLE 2-2</b>	<b>AREA (In acres)</b>
Grass	Akina silty clay	B	61	2.40 Ac.
Grass	Guam cobbly clay loam	D	80	0.20 Ac.
Impervious (roads, roofs, driveways)	Akina silty clay	B/D	98	2.30 Ac.
<b>AREA SUBTOTALS:</b>				<b>4.90 Ac.</b>
<b>Time of Concentration</b>	<b>Surface Cover</b>	<b>Manning 'n' Pipe Diameter</b>	<b>Flow Length Avg Velocity</b>	<b>Slope Tc (Hrs)</b>
2-Yr 24 Hr Rainfall = 7.0 In				
<b>Sheet Flow</b>	dense grass	'n'=0.24	50 Ft.	3.00% 0.08 Hrs
<b>Shallow Flow</b>	Short Grass Pasture		50 Ft. 7.00 F.P.S.	2.00% 0.01 Hrs.
<b>Channel Flow</b>		'n'=0.130	1080 Ft.	2.00% 0.14 Hrs.
<b>Total Area in Acres =</b>	<b>4.90 Ac.</b>	<b>Total Sheet Flow=</b>	<b>Total Shallow Flow=</b>	<b>Total Channel Flow=</b>
<b>Weighted CN =</b>	<b>79</b>	<b>0.08 Hrs.</b>	<b>0.01 Hrs.</b>	<b>0.14 Hrs.</b>
<b>Time Of Concentration =</b>	<b>0.23 Hrs.</b>	<b>RAINFALL TYPE IA</b>		
<b>STORM</b>	<b>Precipitation (P) inches</b>	<b>Runoff (Q)</b>	<b>Qp, PEAK DISCHARGE</b>	<b>TOTAL STORM Volumes</b>
<b>1 Year</b>	<b>3.5 In.</b>	<b>1.57 In.</b>	<b>1.7 CFS</b>	27,926 Cu. Ft.
<b>25 Year</b>	<b>20.0 In.</b>	<b>17.1 In.</b>	<b>21.4 CFS</b>	304,691 Cu. Ft.

**Step 2: Determine if the development site and conditions are appropriate for the use of an infiltration basin.**

Table 4.10 presents site-specific data, such as soil type, percolation rate, and slope, for consideration in the design of the infiltration basin.

**Table 4.10 Site Specific Data for Mountain View Estates**

Criteria	Value
Soil	Limestone
Percolation Rate	1.5 in/hour
Ground Elevation at BMP	392 ft
Seasonally High Water Table	379 ft
Soil slopes	<2%

<b>Step 3: Confirm local design criteria and applicability.</b>
---

**Table 4.11**, below, summarizes the requirements that need to be met to successfully implement infiltration practices. On this site, infiltration is feasible, with restrictions on the depth and width of the basin.

**Table 4.11 Infiltration Basin Feasibility**

Criteria	Status
Infiltration rate ( $f_c$ ) greater than or equal to 0.5 in/hour.	Infiltration rate is 1.5 in/hour. OK.
Soils have a clay content of less than 20% and a silt/clay content of less than 40%.	Limestone meets both criteria.
Infiltration cannot be located on slopes greater than 6% or in fill soils.	Slope is <2%; not fill soils. OK.
Hotspot runoff should not be infiltrated.	Not a hotspot land use. OK.
The bottom of the infiltration facility must be separated by at least 3 ft vertically from the seasonally high water table.	Elevation of seasonally high water table: 379 ft Elevation of BMP location: 391 ft. The difference is 12 ft. Thus, the basin can be up to 9 ft deep. OK.
Infiltration facilities must be located 100 ft horizontally from any water supply well.	No water supply wells nearby. OK.
Maximum contributing area generally less than 10 acres.	Area draining to facility is less than 5 acres. OK.
Setback 25 ft down-gradient from structures.	Basin edge is > 25 ft from all structures. OK.

#### Step 4: Calculate the required surface area.

Calculate the surface area of trapezoidal\* infiltration basins using the following equation from **Volume I, Section 3.2.4.3.d**:

$$A_b = (2V_w - A_t * db) / (db - P/6 + f_c T/6)$$

Where:

$V_w$  = design volume (ft<sup>3</sup>)

$A_t$  = area at the top of the basin (ft<sup>2</sup>) = length (L) \* width (W)

$db$  = depth of the basin (ft) (separated at least three feet from seasonally high groundwater)

$P$  = design rainfall depth (in)

$f_c$  = infiltration rate (in/hr)

$T$  = time to fill basin (hours) (assumed to be 2 hours for design purposes)

$z$  = side slope z:1

$A_b$  = surface area at the bottom of the basin (ft<sup>2</sup>) = (L - 2\*z\*db) (W - 2\*z\*db)

\*Basins do not need to be trapezoidal – use this to approximate required surface area.

$$\text{So: } A_b = (2 * (6.93 \text{ ac-ft} * 43,560 \text{ ft}^2/\text{ac})) - (A_t) (db) / (db - (20.0 \text{ in}/6) + (1.5 \text{ in/hr} * 2 \text{ hr}/6))$$

Using the available area on the site and keeping a slope of 3:1, use trial and error to solve for  $A_b$  by varying  $A_t$  and  $db$ . For this site, there is an area of 54,250 ft<sup>2</sup> available for the basin, or roughly 164.7ft x 329.4ft.

$$\text{So } A_b = (2 * (6.93 \text{ ac-ft} * 43,560 \text{ ft}^2/\text{ac})) - (53,000 \text{ ft}^2) (db) / (db - (20.0 \text{ in}/6) + (1.5 \text{ in/hr} * 2 \text{ hr}/6)) \text{ and } A_b = (329.4 \text{ ft} - 2 * 3 * db) (164.7 \text{ ft} - 2 * 3 * db)$$

Solve by setting the equations equal to one another using a spreadsheet or trial and error. For a basin depth of  $db = 8$  ft and  $A_b = \sim 32,800$  ft<sup>2</sup>, the equations balance. The final basin will be 9 ft deep, which provides 1 ft of freeboard.

#### Step 5: Size pretreatment.

Infiltration basins should have redundant methods to protect the long-term integrity of the infiltration rate. Use a sediment forebay at the outfall of the dry swale for additional sediment removal. Size forebay using the equation in **Volume I, Section 3.2.4.4c**:

$$A_s = 0.066 (WQ_v) = 0.066 * (6,674 \text{ ft}^3 * 0.25)$$

$$A_s = 110 \text{ ft}^2$$

Use a minimum 3 ft depth with a length to width ratio of 1.5:1. Sediment forebay dimensions should be approximately 8.5 ft x 13 ft with a depth of 3 ft.

**Step 6: Design spillway.**

Locate an emergency overflow spillway at downstream edge of infiltration facility for passage of storms greater than the 25-yr event. Set the spillway invert at elevation 391.0 ft for a foot of freeboard and design according to spillway criteria in **Section 6.1**. This is considered an excavated pond rather than an embankment pond. “Token” spillways (those placed above the water elevation of the largest managed storm) must be a minimum 8 ft wide, 1 ft deep, with a minimum of 2:1 side slopes.



## 4.2 Case Study #2: Commercial Site in Guam

This case study represents a portion of a commercial site located in Hagatna, Guam. The Capitol Beach Shopping Center (see **Figure 4.8**) is a hypothetical commercial development which includes a restaurant and a bank, as well as other shops, businesses and green space. The total site area is 20 acres, with 65% impervious cover.

The following examples show how to manage the stormwater from the three small subcatchments associated with the restaurant and the bank that have a total site area of approximately 1.45 acres. The three catchments each drain to separate stormwater treatment practices, ultimately discharging to Agana Bay. Catchment A drains to the SW portion of the site and is comprised of 0.78 acres with 90% impervious cover; Catchment B drains to the SE portion of the site and is comprised of 0.46 acres with 79% impervious cover; and Catchment C drains to the middle portion of the site and is comprised of 0.19 acres with 89% impervious cover. While the impervious percentage of each subcatchment is greater than 70%, the site as a whole still meets the post-construction criteria of less than 70% impervious cover for developments over 1 acre. On-site soils as determined by the NRCS soil maps are classified as “Urban Land.”

Three stormwater practice design examples are presented for this case study, consisting of a bioretention system with a grass channel for pretreatment, a bioretention system with a grass filter strip for pretreatment, and a perimeter sand filter. This case study is a good example of how to effectively, and more aesthetically, treat stormwater close to the source instead of the traditional technique of using one large practice to handle the runoff from the entire 20-acre development.

**Table 4.11 Base Data for Capitol Beach Shopping Center**

<p><b>Location:</b> Hagatna, Guam</p> <p><b>Drainage Area A</b></p> <p><b>Site Area:</b> 0.78 acres</p> <p><b>Impervious Area:</b> 0.7 acres</p> <p><b>Soils Type:</b> Urban Land</p>	<p><b>Drainage Area B</b></p> <p><b>Site Area:</b> 0.46 acres</p> <p><b>Impervious Area:</b> 0.42 acres</p>
	<p><b>Drainage Area C</b></p> <p><b>Site Area:</b> 0.19 acres</p> <p><b>Impervious Area:</b> 0.17 acres</p>

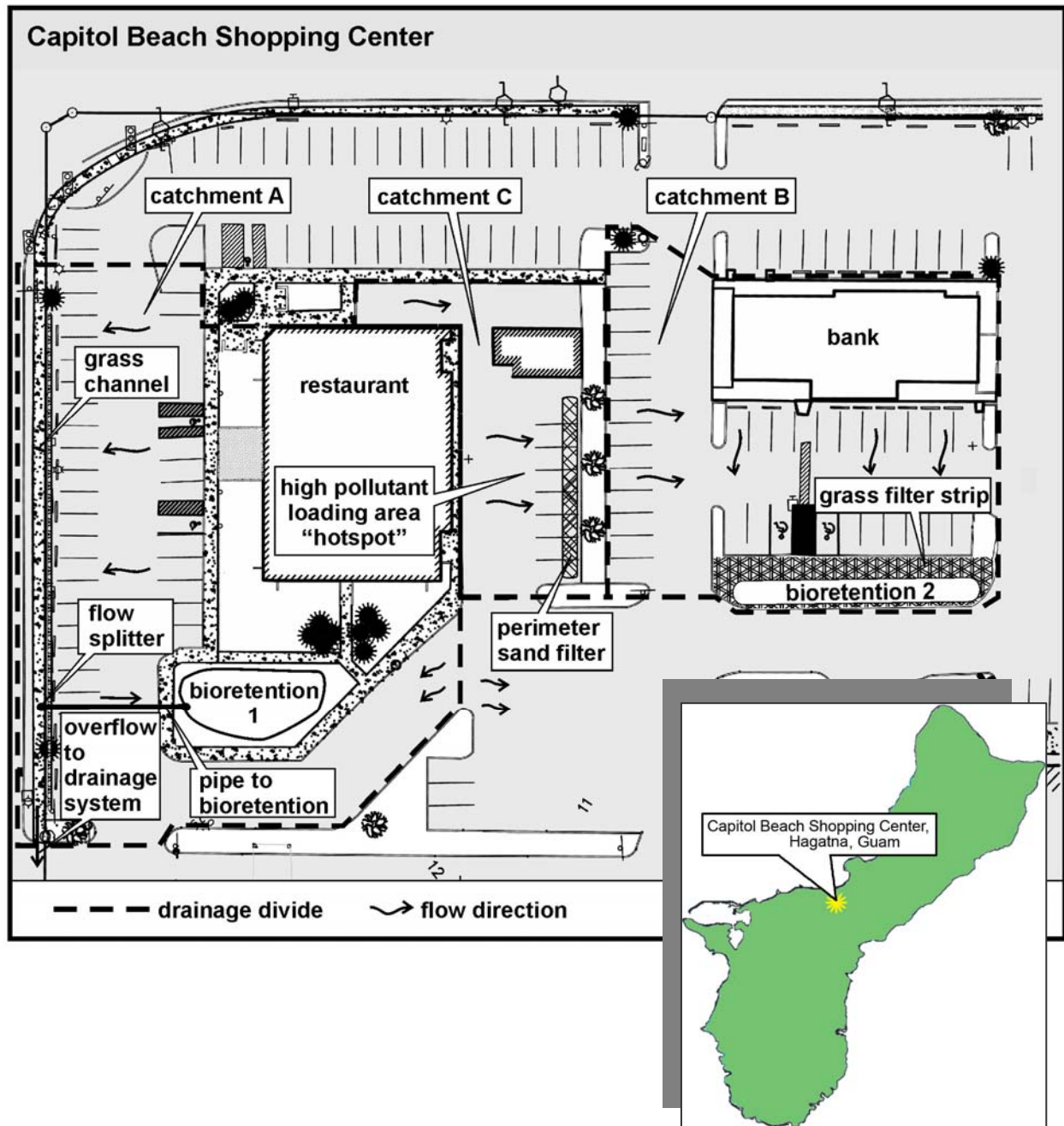
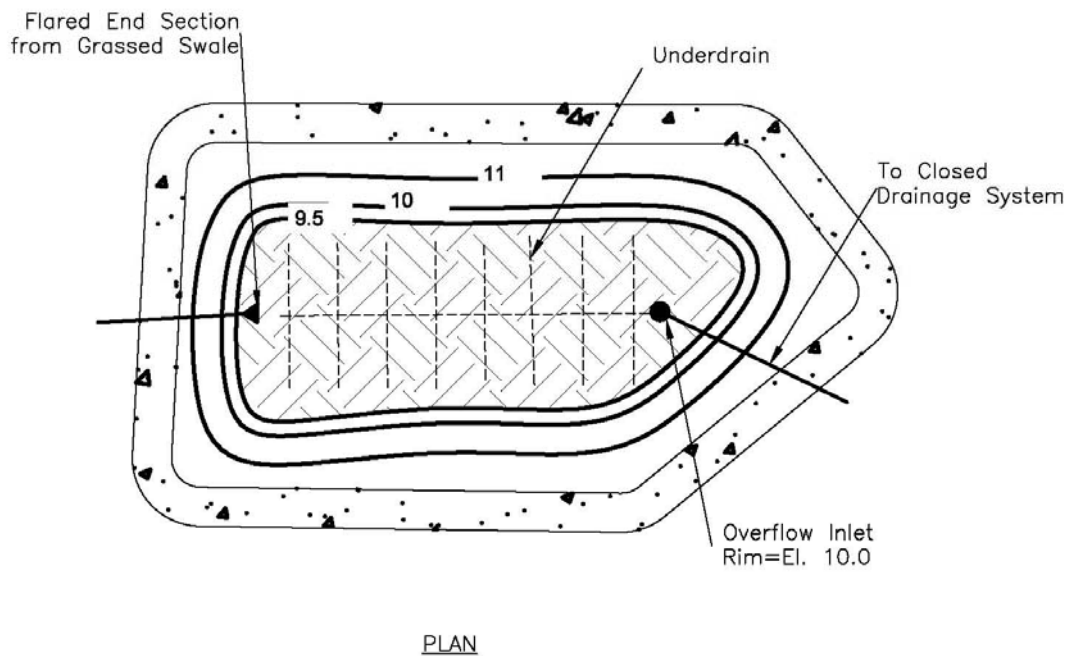


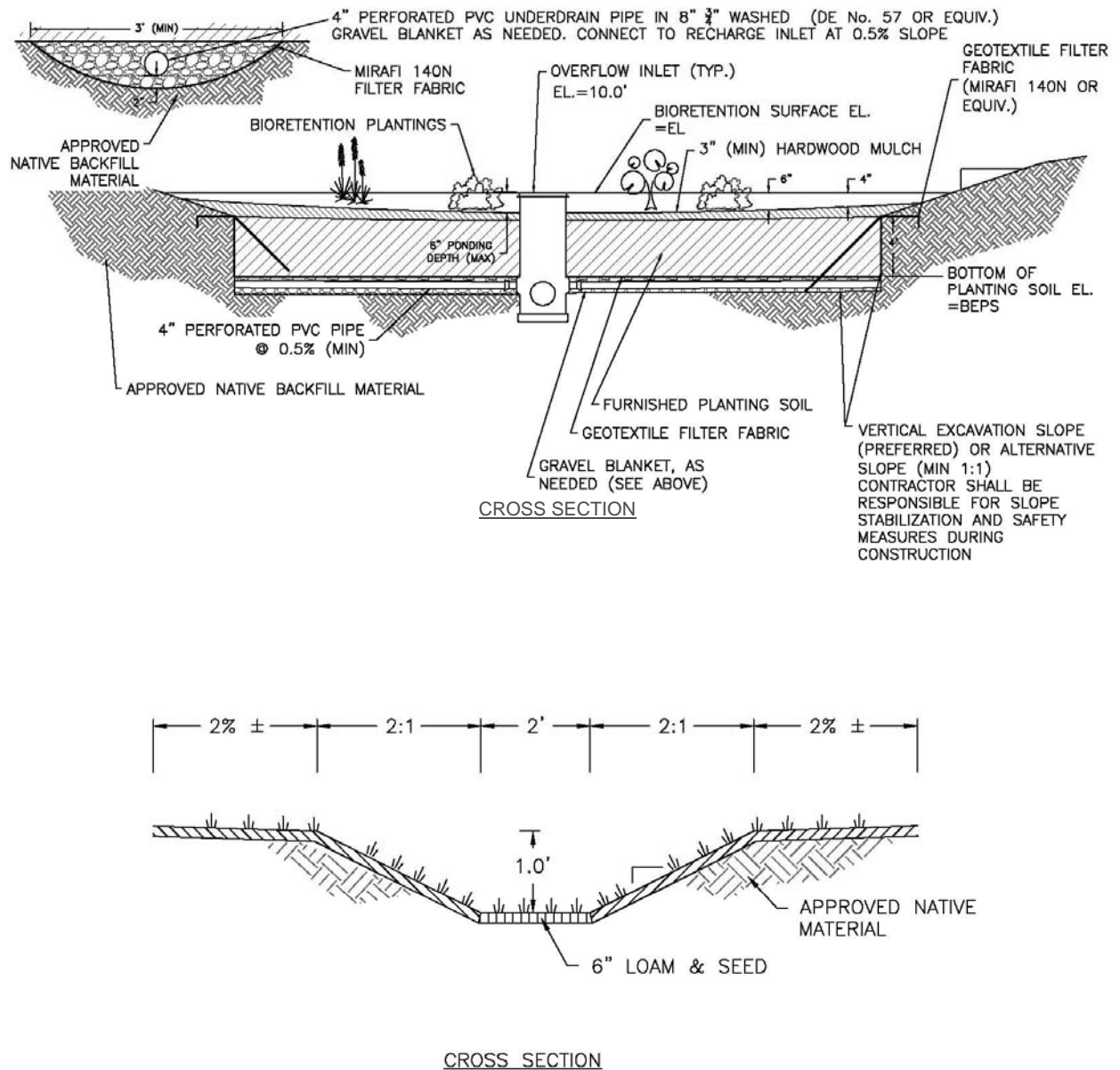
Figure 4.8 Capitol Beach Shopping Center - Commercial Site Plan on Guam

#### 4.2.1 Bioretention Design Example with Grass Channel Pretreatment

This example focuses on the design of a bioretention system associated with catchment area “A” of the Capitol Beach Shopping Center commercial development (see **Figure 4.8**), which drains to the SW portion of the site and is comprised of 0.78 acres with 90% impervious cover. This step-by-step example shows how the recharge volume and water quality volume requirements for this portion of the site will be met by the bioretention system. In addition, this example will show how to design a grass channel for pretreatment. In general, the primary function of bioretention facilities is to provide water quality treatment and not large storm attenuation. As such, flows in excess of the water quality volume are typically routed to a downstream facility for large storm attenuation. For this example, the channel protection and peak control requirements are not required because the site ultimately discharges to Agana Bay, a tidally-influenced body of water (see **Volume I, Section 2.2.2.3**).



**Figure 4.9** Plan View of Bioretention with Grass Swale



**Figure 4.10 Typical Sections of a Bioretention Facility and a Grass Swale**

**Step 1: Compute Recharge Volume ( $Re_v$ ) and the Water Quality Volume ( $WQ_v$ ) using the Unified Stormwater Sizing Criteria**

**Recharge,  $Re_v$**

The site is located in the limestone region of the island (**Volume I, Figure 2.1**), so use  $P = 1.5$  in.

$$\begin{aligned}
 Re_v &= [(P) (I) (A)] / 12 \\
 &= [(1.5 \text{ in}) (0.9) (0.78 \text{ ac})] (1\text{ft}/12\text{in}) \\
 &= \underline{0.088 \text{ ac-ft}}
 \end{aligned}$$

### Water Quality Volume, $WQ_v$

Consult **Volume I, Figure 2.1** to determine the quality of the site. This site is in the S3 freshwater area on Guam, and ultimately discharges to the M2 marine area. Both areas fall under the 80% capture rule (note: if areas fell under different categories, the more stringent rule would apply).

$$\begin{aligned} WQ_v &= [(P) (I) (A)] / 12 \\ &= [(0.8 \text{ in}) (0.9) (0.78 \text{ ac}) (1 \text{ ft}/12 \text{ in})] \\ &= \underline{0.047 \text{ ac-ft}} \end{aligned}$$

The  $WQ_v$  is less than the  $Re_v$  – thus, no additional volume must be treated other than the  $Re_v$ . Bioretention will be designed without an impermeable liner (as an exfilter) to allow for infiltration. Total  $WQ_v$  to be treated by the bioretention facility is:  $\underline{WQ_v = 0.088 \text{ ac-ft} = 3822 \text{ ft}^3}$ .

**Step 2: Determine if the development site and conditions are appropriate for the use of a bioretention area.**

Site Specific Data:

Existing ground elevation at practice location is 10.0 ft, mean sea level. Soil boring observations reveal that the seasonally high water table is at 2.0 ft and underlying soil is urban fill over limestone.

**Step 3: Confirm local design criteria and applicability.**

There are no additional local criteria that must be met for this design.

**Step 4: Determine size of bioretention filter area.**

Use sizing equation and values provided in **Volume I, Section 3.2.4.4d**:

$$A_f = (WQ_v) (d_f) / [(k) (h_f + d_f) (t_f)]$$

Where:

- $A_f$  = surface area of filter bed ( $\text{ft}^2$ )
- $d_f$  = filter bed depth (ft) (use 4 ft per **Volume I**, 1.5 ft min. allowed with designer justification)
- $k$  = coefficient of permeability of filter media (ft/day)
- $h_f$  = average height of water above filter bed (ft) (max 6in allowed, so ave = 0.25ft)
- $t_f$  = design filter bed drain time (days) (48 hours is recommended)

$A_f = (3,822 \text{ ft}^3) (4 \text{ ft}) / [(1 \text{ ft /day}) (0.25\text{ft} + 4 \text{ ft}) (2 \text{ days})]$  (With  $d_f = 4 \text{ ft}$ ,  $k = 1.0 \text{ ft /day}$ ,  $h_f = 0.25\text{ft}$ ,  $t_f = 2 \text{ days}$ )

$$A_f = \underline{1,799 \text{ ft}^2}$$

#### Step 5: Set design elevations and dimensions.

Assume a roughly 2:1 rectangular shape. Given a filter area requirement of 1,799 ft<sup>2</sup>, say facility is roughly 30ft by 60ft. See **Figure 4.9**. Set top of facility at 10.0 ft, with the berm at 11.0 ft. The facility is 5 ft deep from rim to bottom of planting area, which will allow 3 ft of clearance above the seasonally high water table. See **Figure 4.10** for a typical section of the facility.

#### Step 6: Design conveyance to facility.

Stormwater treatment practices can be either on or off-line. On-line facilities are generally sized to receive, but not necessarily treat, larger storms. Off-line facilities are designed to receive a more or less exact flow rate through a weir, channel, manhole “flow splitter”, etc. The facility in this example is situated to receive only the  $WQ_v$  via a flow splitter in a grass channel.

To design a flow splitter for this offline bioretention area, refer to **Section 9.3** for guidance on Water Quality Peak Flow Calculation.

Using the water quality volume ( $WQ_v$ ), a corresponding Curve Number (CN) is computed utilizing the following equation:

$$CN = 1000 / [10 + 5P + 10Q - 10(Q^2 + 1.25 QP)^{1/2}]$$

Where P = rainfall, in inches (use 1.5in in this case – see **Step 1**)

Q = runoff volume, in inches (equal to  $WQ_v \div \text{area}$ )

$Q = (0.088 \text{ ac-ft}) (12 \text{ inches/ft}) / (0.78 \text{ acres}) = 1.35 \text{ inches}$

$$CN = 1000 / [10 + 5(1.5 \text{ in}) + 10(1.35 \text{ in}) - 10((1.35 \text{ in})^2 + 1.25 (1.35 \text{ in})(1.5 \text{ in}))^{1/2}]$$

$$CN = 1000 / [10 + 7.5 + 13.5 - 20.87] = 98.7$$

The time of concentration ( $t_c$ ) is calculated as 2.3 min, but use a minimum of 5 min (0.08 hr).

Read initial abstraction ( $I_a$ ) from TR-55 Table 4.1 or calculate  $I_a = 200/CN - 2 = 0.026$

Compute  $I_a/P = 0.026 / 1.5 \text{ in} = 0.0173$

Approximate the unit peak discharge ( $q_u$ ) from TR-55 Exhibit 4-IA for appropriate  $t_c$ .

$$q_u = 180 \text{ csm/in}$$

Using the water quality volume ( $WQ_v$ ), compute the peak discharge ( $Q_p$ )

$$Q_p = q_u * A * WQ_v$$

where

- $Q_p$  = the peak discharge, in cfs
- $q_u$  = the unit peak discharge, in cfs/mi<sup>2</sup>/inch (180 csm/in)
- $A$  = drainage area, in square miles (0.00122 sq miles)
- $WQ_v$  = Water Quality Volume, in watershed inches (1.35 inches)

$$Q_p = 180 * 0.00122 * 1.35 = 0.3 \text{ cfs}$$

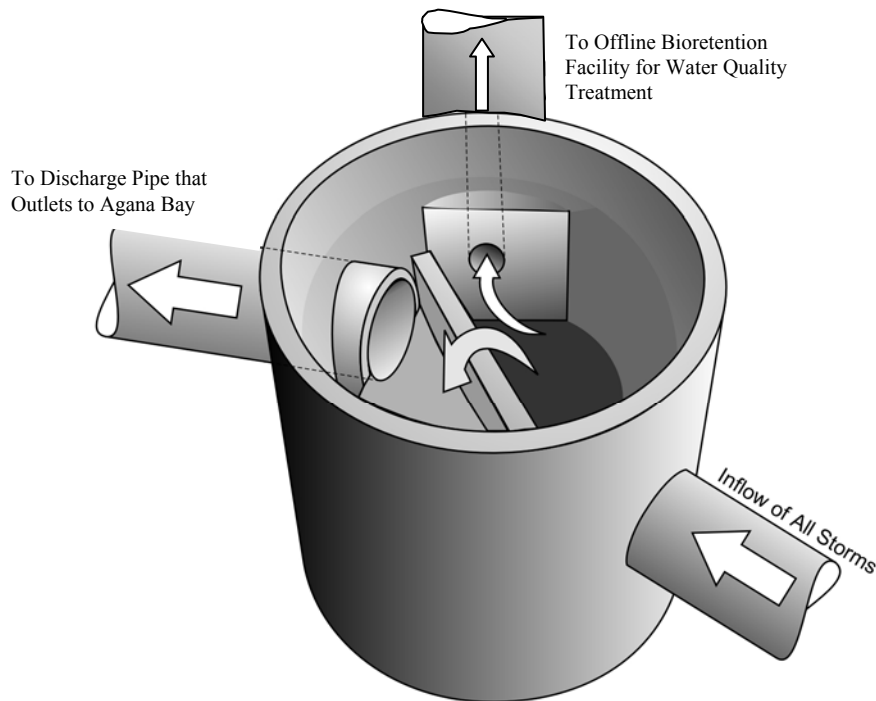
Use the orifice equation to size pipe to bioretention area.  $Q_p = CA(2gh)^{1/2}$

where:

- $C$  = discharge coefficient (0.6)
- $A$  = cross-section area of orifice ( $D^2/4*\pi$ )
- $g$  = acceleration due to gravity (32.2 ft/s<sup>2</sup>)
- $h$  = head, height above the center of the orifice (assume 1 ft)

$$A = Q_p / [C * (2gh)^{1/2}] = 0.3 \text{ cfs} / [0.6 * (2*32.2 \text{ ft/s}^2 * 1 \text{ ft})^{1/2}] = 0.062 \text{ ft}^2$$

Diameter = 3.38 in. Use 6in pipe with 3.5 in restricter.



**Figure 4.11 Flow Splitter Design**

**Step 7: Design pretreatment.**

Pretreat with a grass channel. Assume trapezoidal grass channel dimensions of 2 ft bottom width, 2:1 side slopes, and 1 ft depth, with a cross-sectional area = 6 ft<sup>2</sup>. Size for 25% of WQ<sub>v</sub> (3,822 ft<sup>3</sup>). The length can be determined by the following equation (**Volume I, Section 3.2.4.4c**):

$$L = WQ_v / A = 3,822 \text{ ft}^3 / 6 \text{ ft}^2 * 0.25 = 160 \text{ ft}$$

Given the site layout, 175ft is available for a grass channel along the parking lot, which is greater than the required length, OK.

**Step 8: Size underdrain area.**

Because this bioretention area is designed as an exfilter, an underdrain may not be necessary. However, an underdrain system can still be installed to ensure proper drainage if the area beneath the practice becomes clogged and no longer infiltrates properly. As a rule of thumb, the length of underdrain can be based on 10% of the A<sub>f</sub> or 152 ft<sup>2</sup> and a 3 ft wide zone of influence. See **Figures 4.9 and 4.10**. Using 4 in perforated plastic pipes surrounded by a 3ft-wide washed, rounded limestone aggregate bed, 10 ft on center (o.c.), yields the following length of pipe:

$$(152 \text{ ft}^2) / 3 \text{ ft per foot of underdrain} = \underline{51 \text{ ft of perforated underdrain}}$$

**Step 9: Overflow design.**

Since the bioretention is designed as an off-line practice sized to treat only the WQ<sub>v</sub>, it theoretically should not overflow. However, should filtering rates become reduced due to facility age or poor maintenance, an overflow weir is provided to prevent flooding until the filter media and plants can be replaced. The overflow weir elevation is set so that a maximum of 6 inches of ponding occurs above the bottom of the bioretention area. In this case, the overflow weir is set at 10.0 ft.

**Step 10: Choose plants for planting area.**

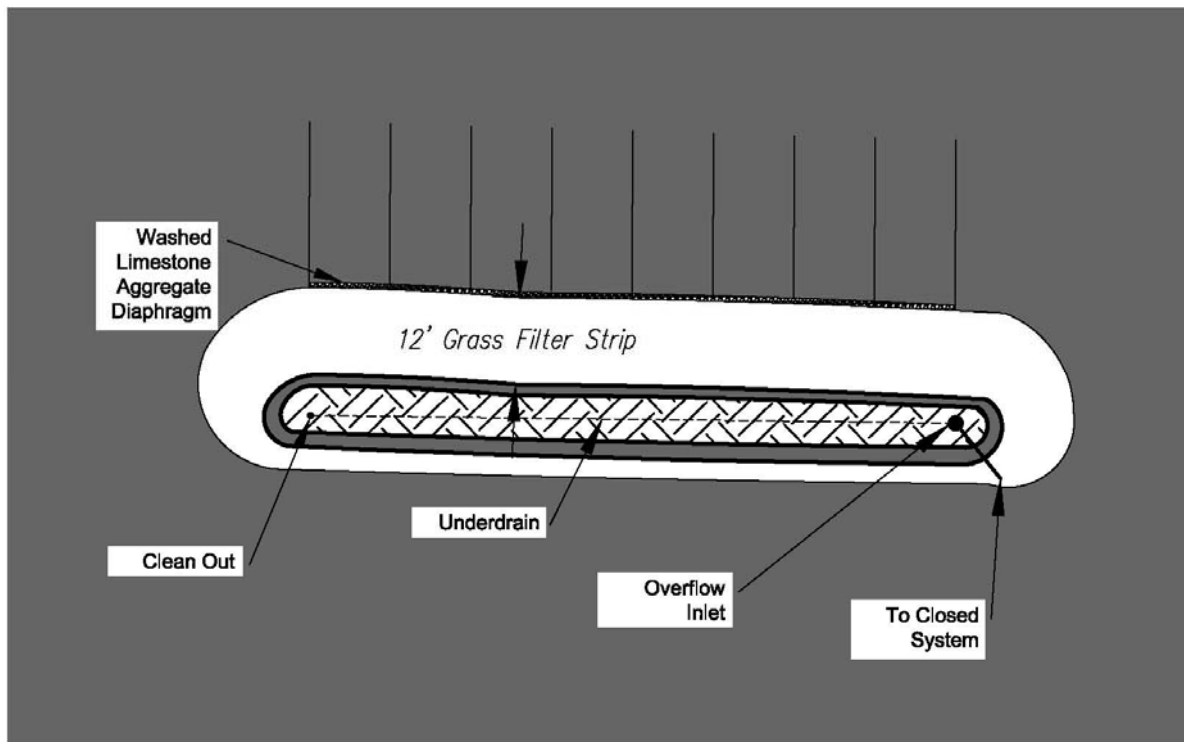
Choose plants based on factors such as whether native or not, resistance to drought and inundation, cost, aesthetics, maintenance, etc. Select species locations (i.e., on center planting distances) so species will not “shade out” one another. Do not plant trees and shrubs with extensive root systems near pipe work. Planting guidelines for this practice are presented in **Chapter 5**.



#### 4.2.2 Bioretention Design Example with Filter Strip Pretreatment

This example focuses on the design of a bioretention system associated with catchment area “B” of the Capitol Beach Shopping Center commercial development (see **Figure 4.8**), which drains to the SE portion of the site and is comprised of 0.46 acres with 79% impervious cover. This step-by-step example shows how the recharge volume and water quality volume requirements for this portion of the site will be met by the bioretention system. In addition, this example will show how to design a filter strip for pretreatment. For this example, the channel protection and peak control requirements are waived since the ultimate discharge flows to coastal waters. In general, the primary function of bioretention facilities is to provide water quality treatment and not large storm attenuation. As such, flows in excess of the water quality volume are typically routed to a downstream facility, such as conventional detention basins or some other facility such as underground storage vaults.

Follow the sizing calculations from **Section 4.2.1** for the bioretention design. Pretreatment and overflow designs for catchment area “B” are discussed below.



**Figure 4.12** Plan View of Bioretention with Filter Strip

<b>Step 1: Design pretreatment.</b>
-------------------------------------

Volume I, Table 3.4 (also provided below).

**Guidelines for Filter Strip Pretreatment Sizing**

Parameter	Impervious Parking Lots				Residential Lawns			
	Maximum Inflow Approach Length (ft.)	35		75		75		150
Filter Strip Slope	≤2%	≥2%	≤2%	≥2%	≤2%	≥2%	≤2%	≥2%
Filter Strip Minimum Length	10'	15'	20'	25'	10'	12'	15'	18'

The maximum inflow approach length is 60 ft with a slope of 2%, so a filter strip length of 20' is required. However, our site only has 12' available for a filter strip, so use a washed, rounded limestone aggregate curtain in addition to meet pretreatment requirements.

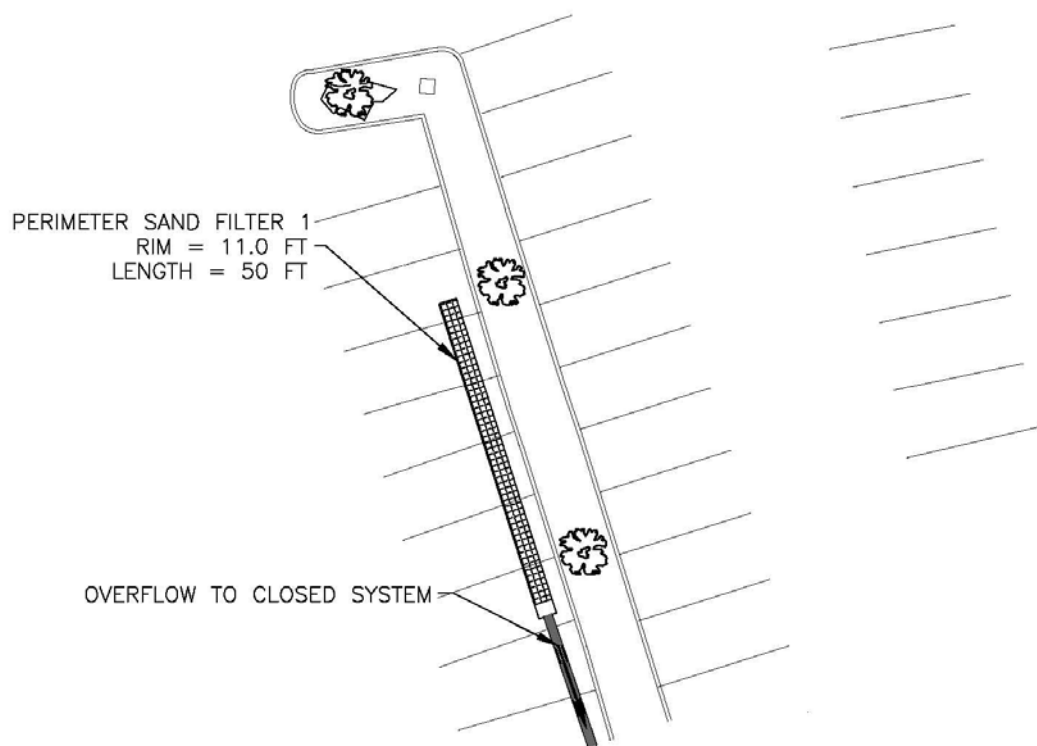
<b>Step 2: Overdrain and Emergency Spillway design.</b>
---

Stormwater treatment practices can be either on or off-line. On-line facilities such as this one receiving direct runoff from the parking lot are generally sized to receive, but not necessarily treat, larger storms. Thus, an overflow weir is provided to pass the 25-year event. The overflow weir elevation is set so that a maximum of 6 inches of ponding occurs above the bottom of the bioretention area. Outlet protection in the form of riprap or a plunge pool/stilling basin should be provided to ensure non-erosive velocities downstream.

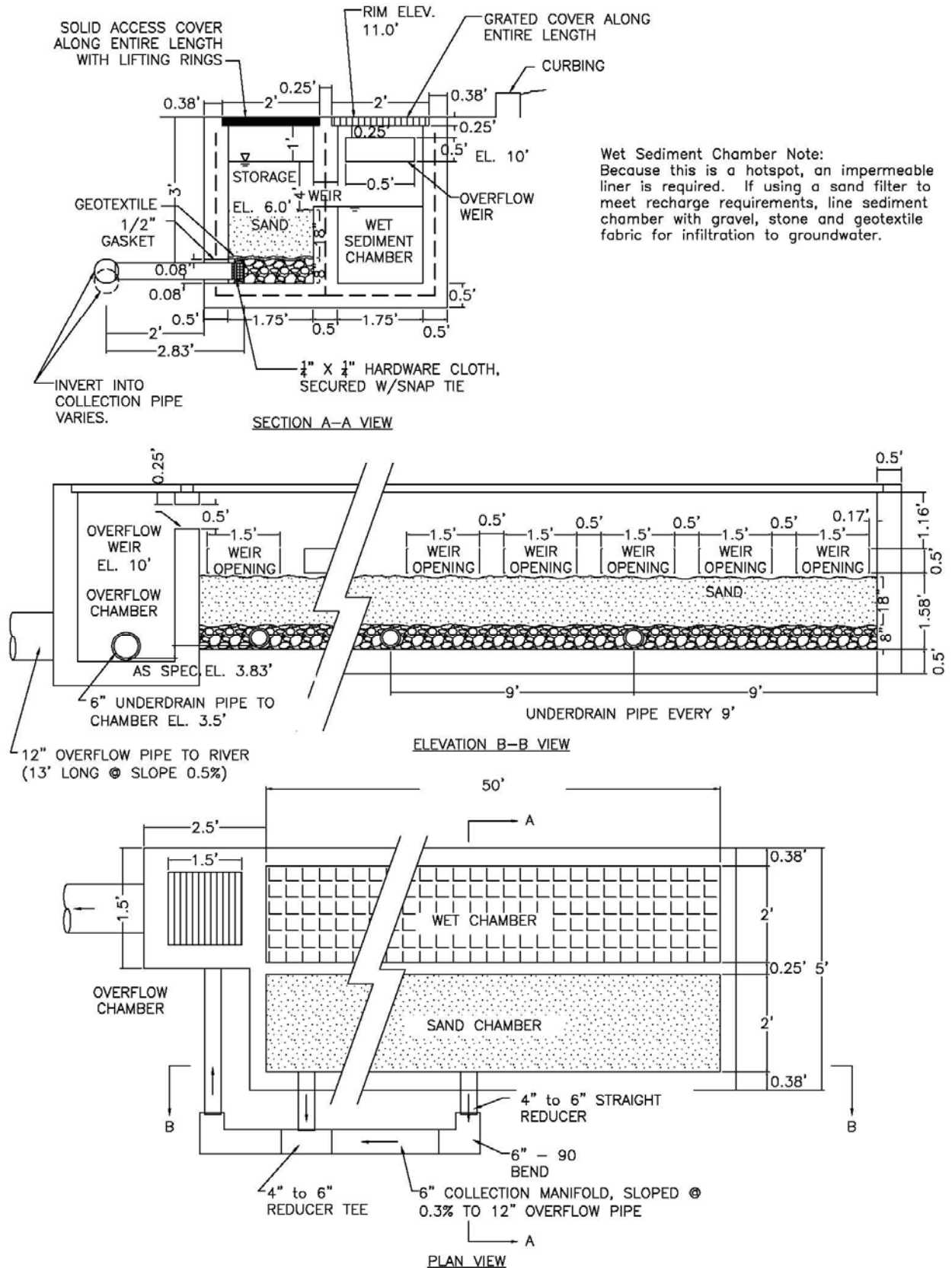
### 4.2.3 Sand Filter Design Example

This example focuses on the design of a perimeter sand filter associated with catchment area “C” of the Capitol Beach Shopping Center commercial development (see **Figure 4.8**), which drains to the middle portion of the site and is comprised of 0.19 acres with 89% impervious cover. This step-by-step example shows how the water quality volume requirements for this portion of the site will be met by the sand filter. It is assumed that this catchment area is located in an area of higher-pollutant load generation. For this example, the recharge volume, channel protection and peak control requirements for this catchment area are not presented. The recharge requirement can be waived given that this site is a hotspot. Channel protection and peak control requirements can also be waived since the site discharges to coastal waters.

In general, the primary function of sand filters is to provide water quality treatment and not large storm attenuation. As such, flows in excess of the water quality volume are typically routed to bypass the facility. The post-development 2-yr peak discharge is provided to appropriately size the necessary by-pass flow splitter. If quantity control is required, bypassed flows are typically routed to conventional detention basins (or some other facility such as underground storage vaults).



**Figure 4.13** Plan View of Sand Filter



**Figure 4.14 Profile and Plan Views of Sand Filter**

**Step 1: Compute water quality volumes using the Unified Stormwater Sizing Criteria.**

Use the 90% capture rule with 1.5in of rainfall for hotspot areas.

$$\begin{aligned} WQ_v &= [(P) (I) (A)] / 12 \\ &= [(1.5 \text{ in}) (0.89) (0.19 \text{ ac}) (1 \text{ ft}/12 \text{ in})] \\ &= \underline{0.021 \text{ ac-ft} = 915 \text{ ft}^3} \end{aligned}$$

Note: For this design example, the 2-year peak discharge will be used to size the bypass flow splitter. Any hydrologic models using SCS procedures, such as TR-20, HEC-HMS, or HEC-1, can be used to perform preliminary hydrologic calculations

**Table 4.13 Summary of Post-development Hydrologic Data for Catchment C**

Condition	P <sub>(2-yr)</sub>	Area	CN	Q <sub>2</sub>
	in	ac		cfs
Post-developed Catchment C	7.0	0.19	96	0.28

**Step 2: Determine if the development site and conditions are appropriate for the use of a perimeter sand filter.**

Site Specific Data:

Existing ground elevation at practice location is 11.0 ft, mean sea level. Soil boring observations reveal that the seasonally high water table is at 2.0 ft.

**Step 3: Confirm local design criteria and applicability.**

There are no additional requirements for this site.

**Step 4: Compute WQ<sub>v</sub>, available head, & peak discharge (Q<sub>p-wq</sub>).**

- Determine available head (See Figures 4.13 and 4.14)

Low point at edge of facility is 11.0 ft. Subtract 1 ft to pass Q<sub>2</sub> discharge (10.0 ft). Set outfall underdrain pipe at 3.5 ft and add 4 in to this value for drain slope (3.83 ft). Add to this value 8 in for the washed, rounded limestone aggregate blanket over the underdrains, and 18 in for the sand bed (6.0 ft). The total available head is 10.0 ft – 6.0 ft or 4.0 ft. Therefore, the average depth, h<sub>f</sub>, is (h<sub>f</sub>) = 4.0 ft / 2, and h<sub>f</sub> = 2.0 ft.

**Step 5: Size flow diversion structure:**

Size the 2-year overflow as follows:

The 2-year wsel is set at 11.0 ft. Use a concrete weir to pass the 2-year flow (0.28 cfs) into an overflow chamber using the Weir equation. Assume 1 ft of head to pass this event.

$$Q = CLH^{3/2}$$

$$0.28 = 3.1 (L) (1\text{ft})^{1.5}$$

$L = 0.09$  ft; use  $L = 0.5$  ft which sets the flow diversion chamber dimension.

Weir wall elevation = 10.0 ft.

**Step 6: Size filtration bed chamber (see Figure 4.13).**

Use sizing equation provided in **Volume I, Section 3.2.4.4d**:

$$A_f = (WQ_v) (d_f) / [(k) (h_f + d_f) (t_f)]$$

Where:

- $A_f$  = surface area of filter bed (ft<sup>2</sup>)
- $d_f$  = filter bed depth (ft), use 1.5ft
- $k$  = coefficient of permeability of filter media (ft/day), use 3.5ft/day
- $h_f$  = average height of water above filter bed (ft), use 2.0ft
- $t_f$  = design filter bed drain time (days) (40 hours = 1.67 days is recommended)

$$A_f = (915 \text{ ft}^3) (1.5\text{ft}) / [(3.5\text{ft/day}) (2\text{ft} + 1.5\text{ft}) (1.67 \text{ days})] \text{ (With } d_f = 1.5\text{ft, } k = 3.5\text{ft/day, } h_f = 2.0\text{ft, } t_f = 1.67 \text{ days)}$$

$A_f = \underline{67.1 \text{ ft}^2}$  = use 75 ft<sup>2</sup> with a width of 1.75 ft and length of 43 ft.

**Step 7: Size sedimentation chamber.**

From Camp-Hazen equation shown in **Volume I, Section 3.2.4.4c**:  $A_s = 0.066 (WQ_v)$

$$A_s = 0.066 (915 \text{ ft}^3) \text{ or } \underline{60.4 \text{ ft}^2}$$

given a width of 1.75 ft, the minimum length will be  $60.4 \text{ ft}^2 / 1.75 \text{ ft}$  or 34.5 ft (so, use 43.0 ft to match filter length for easy construction)

**Step 8: Compute  $V_{\min}$ .**

$V_{\min}$  is the minimum volume that must be held by the entire system at one time (see **Volume I, Section 3.2.4.4d**).

$$V_{\min} = \frac{3}{4}(WQ_v) \text{ or } 0.75 (915 \text{ ft}^3) = \underline{687 \text{ ft}^3}$$

**Step 9: Compute volume within practice (iterate if necessary).**

Volume within filter bed ( $V_f$ ):  $V_f = A_f (d_f) (n)$ ;  $n = 0.4$  for sand

$$V_f = (1.75 \text{ ft} * 43 \text{ ft}) (1.5 \text{ ft}) (0.4) = \underline{45 \text{ ft}^3}$$

Temporary storage above filter bed ( $V_{f\text{-temp}}$ ):  $V_{f\text{-temp}} = 2h_f A_f$

$$V_{f\text{-temp}} = 2 (2.0 \text{ ft}) (1.75 \text{ ft} * 43 \text{ ft}) = \underline{300 \text{ ft}^3}$$

Compute remaining volume for sedimentation chamber ( $V_s$ ):

$$V_s = V_{\min} - [V_f + V_{f\text{-temp}}] \text{ or } 687 - [45 + 300] = \underline{342 \text{ ft}^3}$$

Compute height in sedimentation chamber ( $h_s$ ):  $h_s = V_s/A_s$

$(342 \text{ ft}^3) / (1.75 \text{ ft} * 43.0 \text{ ft}) = 4.54 \text{ ft}$  which is larger than the head available (4.0 ft); increase the design length to 46 ft for filter and sedimentation chamber;

Volume within filter bed ( $V_f$ ):  $V_f = A_f (d_f) (n)$ ;  $n = 0.4$  for sand

$$V_f = (1.75 \text{ ft} * 46 \text{ ft}) (1.5 \text{ ft}) (0.4) = \underline{48 \text{ ft}^3}$$

Temporary storage above filter bed ( $V_{f\text{-temp}}$ ):  $V_{f\text{-temp}} = 2h_f A_f$

$$V_{f\text{-temp}} = 2 (2.0 \text{ ft}) (1.75 \text{ ft} * 46 \text{ ft}) = \underline{322 \text{ ft}^3}$$

Compute remaining volume for sedimentation chamber ( $V_s$ ):

$$V_s = V_{\min} - [V_f + V_{f\text{-temp}}] \text{ or } 687 - [48 + 322] = \underline{317 \text{ ft}^3}$$

Compute height in sedimentation chamber ( $h_s$ ):  $h_s = V_s/A_s$

$(317 \text{ ft}^3) / (1.75 \text{ ft} * 46 \text{ ft}) = 3.94 \text{ ft}$  which is less than the head available (4.0 ft); OK.

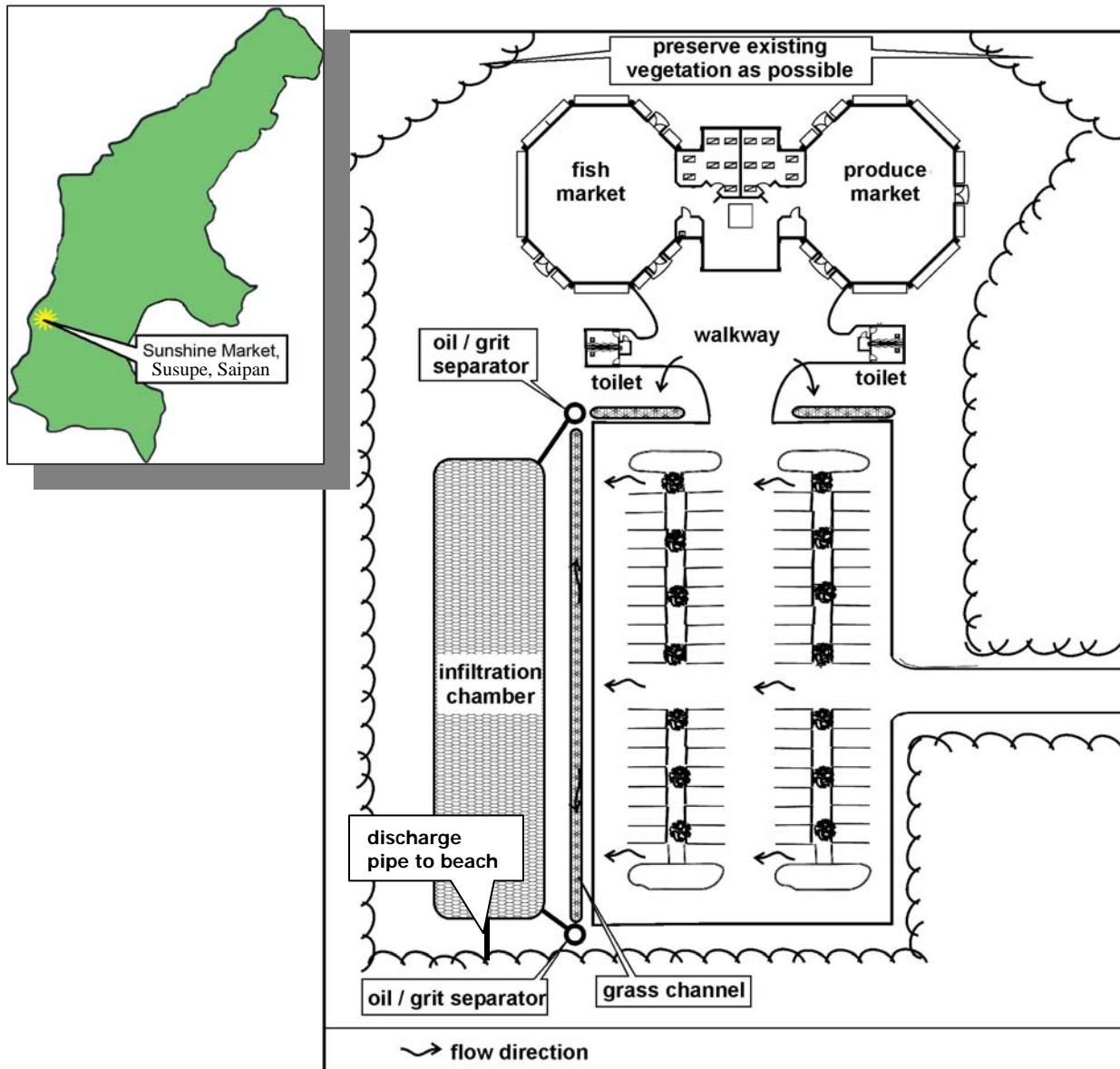
Use 1.75 ft x 46 ft for filter bed and sedimentation chamber dimensions.

**<This page left blank intentionally>**



### 4.3 Case Study #3: Commercial Site in CNMI

This case study represents a commercial site located in Susupe, Saipan in CNMI. The Sunshine Market (see **Figure 4.15**) is a hypothetical commercial development consisting of a fish and produce market with a total site area of approximately 3.0 acres with 52% impervious cover. On-site soils as determined by the NRCS soil maps are Shioya loamy sand and are classified as HSG “A”. Infiltration chambers with a grass channel and oil/grit separator for pretreatment is the design example presented for this case study.



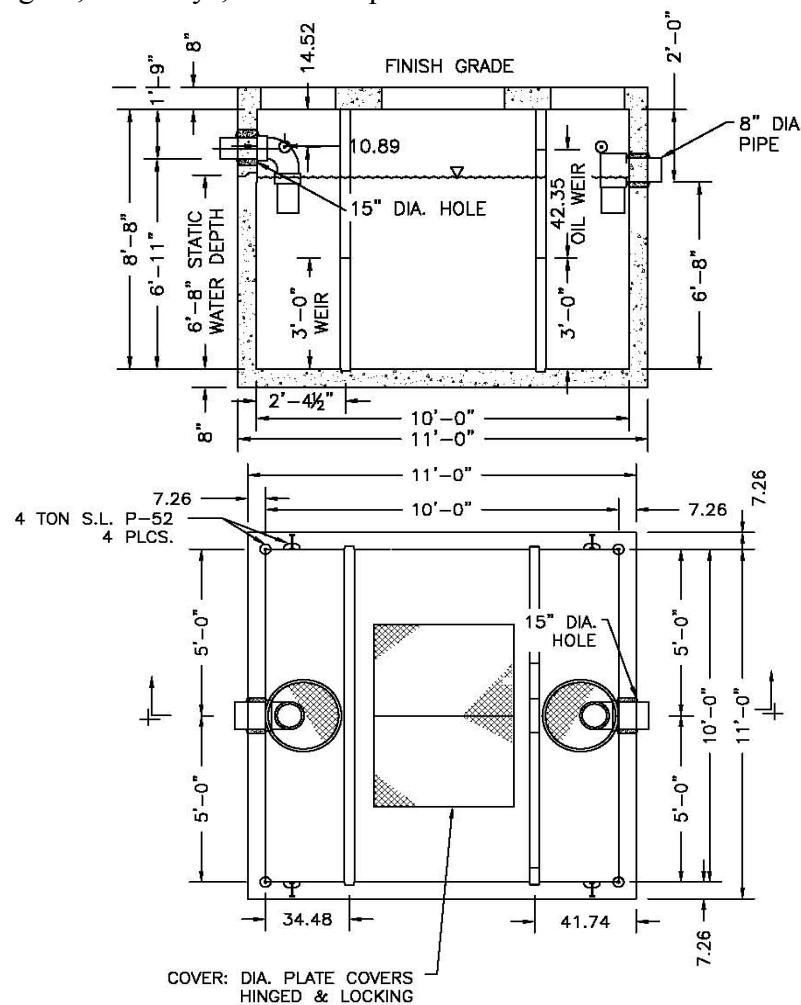
**Figure 4.15 Sunshine Market Site Plan on Saipan**

**Table 4.14 Sunshine Market Base Data**

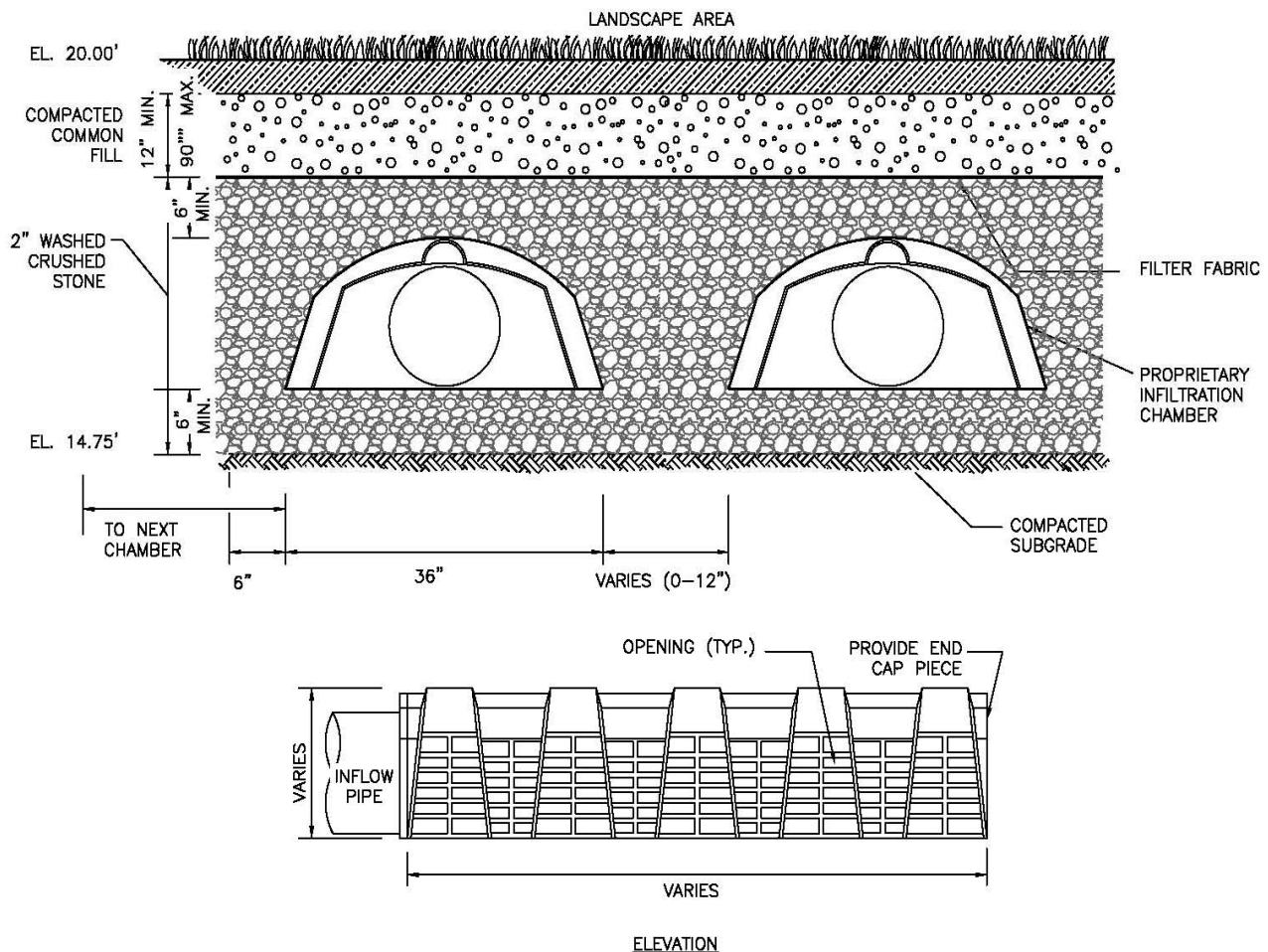
<p><b>Location:</b> Susupe, Saipan (CNMI)  <b>Site Area:</b> 3.0 acres  <b>Impervious Area:</b> 1.56 acres  <b>Soils Type:</b> Shioya loamy sand, "A"</p>
---

**4.3.1 Infiltration Chamber Design Example with Grass Channel and Oil/Grit Separator Pretreatment**

This example focuses on the design of subsurface infiltration chambers associated with the Sunshine Market in Susupe, Saipan (CNMI) (see **Figure 4.15**). This step-by-step example shows how the recharge and water quality volume requirements for this portion of the site will be met by the infiltration chambers. In general, the primary function of the chambers is to provide water quality treatment and groundwater recharge and not large storm attenuation. As such, flows in excess of the water quality volume are typically routed to bypass the facility. In this example, channel protection and overbank flood requirements are waived because flow from these larger storm events is discharged overland to the beach. The infiltration chambers are located in a landscaped area adjacent to the parking lot. The infiltration chambers receive runoff from the parking lot, walkways, and rooftops on the site.



**Figure 4.16 Typical Detail of an Oil/Grit Separator**



**Figure 4.17 Typical Detail of Infiltration Chambers**

**Step 1: Compute recharge and water quality volumes using the Unified Stormwater Sizing Criteria.**

**Recharge,  $Re_v$**

The site is located in the limestone region of the island (**Volume I, Figure 2.2**), so use 1.5 in multiplied by the impervious area.

$$\begin{aligned}
 Re_v &= [(P) (I) (A)] / 12 \\
 &= [(1.5 \text{ in}) (0.52) (3.0 \text{ ac})] (1\text{ft}/12\text{in}) \\
 &= \underline{0.195 \text{ ac-ft} = 8,494 \text{ ft}^3}
 \end{aligned}$$

**Water Quality,  $WQ_v$**

This site is in the Class 1 freshwater area on Saipan, and ultimately discharges to the Class AA marine area (**Volume I, Figure 2.2**). Both areas fall under the 90% capture rule (note: if areas fell under different categories, the more stringent rule would apply).

$$\begin{aligned}
 WQ_v &= [(P) (I) (A)] / 12 \\
 &= [(1.5 \text{ in}) (0.52) (3.0 \text{ ac}) (1\text{ft}/12\text{in})] \\
 &= 0.195 \text{ ac-ft} = 8,494 \text{ ft}^3
 \end{aligned}$$

Re<sub>v</sub> is equal to WQ<sub>v</sub>, so 100 % of the recharge volume is contained within the WQ<sub>v</sub>.

**Step 2: Determine if the development site and conditions are appropriate for the use of infiltration chambers.**

Site Specific Data:

**Table 4.15** presents site-specific data, such as soil type, percolation rate, and slope, for consideration in the design of the infiltration chamber.

**Table 4.15 Site Specific Data for Sunshine Market**

Criteria	Value
Soil	Loamy Sand
Infiltration Rate (f <sub>c</sub> )	2.41 in/hr*
Ground Elevation at BMP	20 ft
Seasonally High Water Table	9 ft
Soil slopes	<1%

\*Determine f<sub>c</sub> from **Table 3.5** in **Volume I**.

**Step 3: Confirm local design criteria and applicability.**

**Table 4.16**, below, summarizes the requirements that need to be met to successfully implement infiltration practices. On this site, infiltration is feasible, with restrictions on the depth and width of the chamber.

**Table 4.16 Infiltration Chambers Feasibility**

Criteria	Status
Infiltration rate (f <sub>c</sub> ) greater than or equal to 0.5 in/hour.	Infiltration rate is 2.41 in/hour. OK.
Soils have a clay content of less than 20% and a silt/clay content of less than 40%.	Loamy sand meets both criteria.
Infiltration cannot be located on slopes greater than 6% or in fill soils.	Slope is <1%; not fill soils. OK.
Hotspot runoff should not be infiltrated.	Not a hotspot land use. OK.
The bottom of the infiltration facility must be separated by at least 3 ft vertically from the seasonally high water table.	Elevation of seasonally high water table: 9 ft Elevation of BMP location: 20 ft. The difference is 11 ft. Thus, the facility can be up to 8 ft deep (but use maximum of 4 ft). OK.
Infiltration facilities must be located 100 ft horizontally from any water supply well.	No water supply wells nearby. OK.
Maximum contributing area generally ≤5 acres.	Area draining to facility is less than 5 acres. OK.
Setback 25 ft down-gradient from structures.	Chamber edge is > 25 ft from all structures. OK.

<b>Step 4: Size the infiltration chamber facility.</b>
--

In general, infiltration chambers can be sized by the equation below. For product-specific sizing, please refer to the manufacturer's instructions.

$$V_w = L * [(w * d * n) - (\# * A_c * n) + (\# * A_c) + (w * f_c * T / 12)]$$

Where:

- V<sub>w</sub> = design volume (e.g., WQ<sub>v</sub>) (ft<sup>3</sup>)
- L = Length of infiltration facility (ft)
- w = width of infiltration facility (ft)
- h = Depth of infiltration facility (ft)
- # = number of rows of chambers
- A<sub>c</sub> = Cross-sectional area of chamber (ft<sup>2</sup>)
- n = Porosity (assume 0.4)
- f<sub>c</sub> = infiltration rate (in/hour)
- T = Fill Time (time for the practice to fill with water), in hours

Assume that:

- n = 0.4
- d = 4 ft (see above; feasibility criteria)
- f = 2.41 in/hour (see above; site data)
- T = 2 hours (this is the recommended default value to be used unless site-specific data exists)
- A<sub>c</sub> = 3.445 ft<sup>2</sup> (supplied by manufacturer)
- # = 15 ft / 3.25 ft (supplied by manufacturer) = 4.6, only 4 rows can fit

Solve for Length given that we have 15 ft – 20 ft of width that we want to use at our site.

Therefore:

$$L = 8,494 \text{ ft}^3 / [(15 \text{ ft} * 4 \text{ ft} * 0.4) - (4 * 3.445 \text{ ft}^2 * 0.4) + (4 * 3.445 \text{ ft}^2) + (15 \text{ ft} * 2.41 \text{ in/hr} * 2 \text{ hr} / 12)]$$

$$L = 8,494 \text{ ft}^3 / [(24 \text{ ft}^2) - (5.5 \text{ ft}^2) + (13.8 \text{ ft}^2) + (6.0 \text{ ft}^2)]$$

$$L = 222 \text{ ft}$$

Add one foot to each end and each side to give room for a stone buffer (this distance could be more or less depending on manufacturer's specifications). Thus, the facility dimensions will be 17 ft x 224 ft. Check to ensure that there is sufficient room for the infiltration chamber facility alongside proposed parking lot. The proposed parking lot is 250 ft long, Ok. (Refer back to **Figure 4.15** for a site plan view).

<b>Step 5: Size pretreatment.</b>
-----------------------------------

For pretreatment, use a grass channel and oil/grit separators as shown in **Figure 4.15**. These should be sized to pretreat 50% of WQ<sub>v</sub> given the infiltration rate of the soil (see **Volume I, Section 3.2.4.3c**).

Pretreatment volume =  $0.5 * WQ_v = (0.195 \text{ ac-ft}) * (43,560 \text{ ft}^2/\text{ac}) * 0.5 = 4,247 \text{ ft}^3$

Use 2, 5,000 gallon oil/grit separators =  $2 * (5,000 \text{ gal} / 7.5 \text{ gal/cf}) = 1,333 \text{ ft}^3$

Size the grass channel to treat the remaining  $2,914 \text{ ft}^3$ . The grass channel is 325 ft long, which means that the cross-section area needs to be  $(2,914 \text{ ft}^3) / (325 \text{ ft}) = 8.97 \text{ ft}^2$ . Use a swale with a 3 ft bottom width, 1.5 ft deep, and 2:1 side slopes.

### 4.4 Case Study #4: Single Family Residential Site in CNMI

This case study represents a single-family residential site located in San Jose, Tinian in CNMI. This single family home (see **Figure 4.18**) is a hypothetical site consisting of a ¼-acre lot. The drainage area used for this example consists of the entire lot and is comprised of 32% impervious cover. On-site soils as determined by the NRCS soil maps are Dandan-Chinen Complex and are classified as HSG “C”. CNMI and Guam regulations do not require that stormwater management practices for single or dual-family residences be designed by an engineer, so a less rigorous approach is acceptable. The stormwater practice design examples presented for this case study are mostly qualitative in nature and are suitable for design and construction by qualified contractors and even enthusiastic homeowners. This example consists of calculations for a cistern to a drywell and descriptions of a rain garden, permeable pavers, and a dry swale.



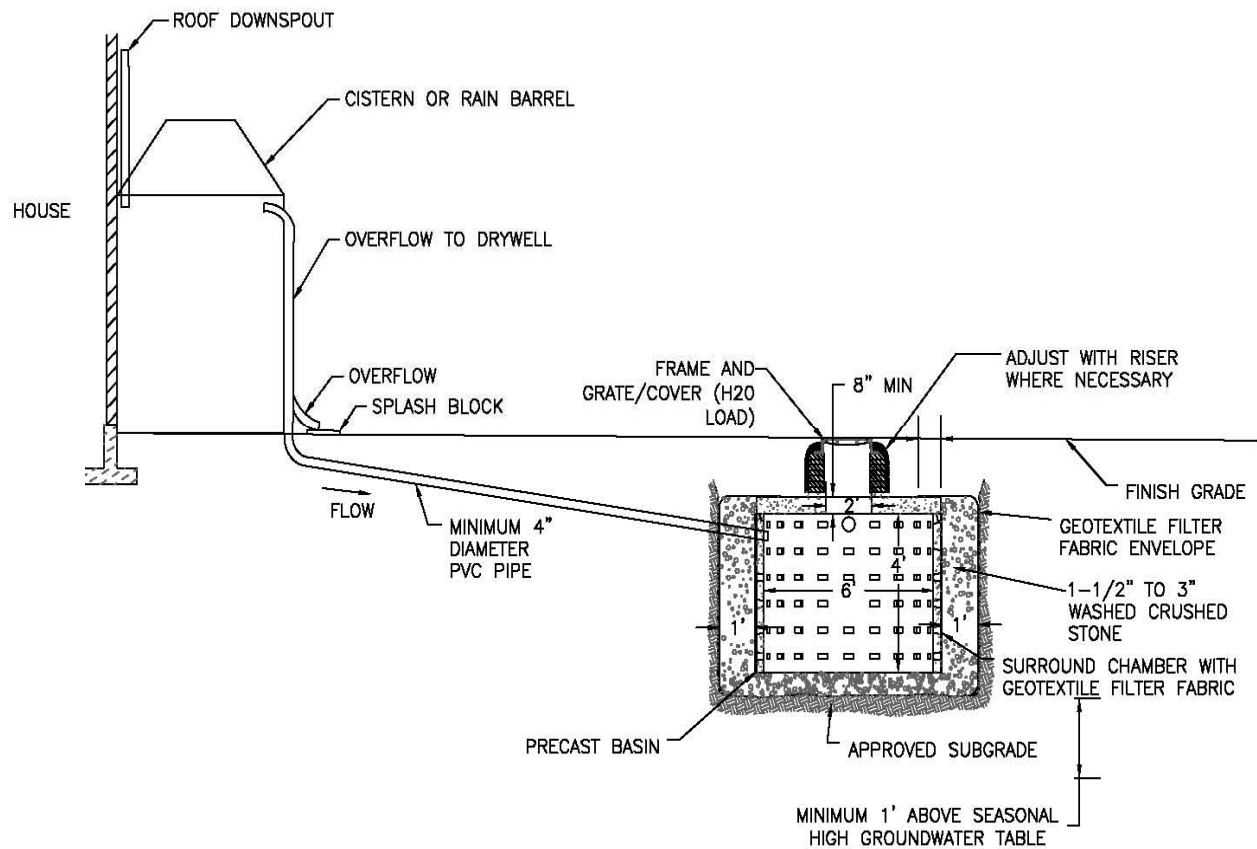
**Figure 4.18 Single-family Residential Site Plan on Tinian**

**Table 4.17 Tinian Single Family Home Base Data**

<p><b>Location:</b> San Jose, Tinian (CNMI)  <b>Site Area:</b> 0.25 acres  <b>Impervious Area:</b> 0.08 acres  <b>Soils Type:</b> Dandan-Chinen Complex, “C”</p>
--

**4.4.1 Cistern and Drywell**

The first part of this example focuses on the design of a cistern and a drywell to intercept rooftop runoff for a single family home located in San Jose, Tinian (CNMI). This example shows how the recharge requirements for this portion of the site will be met by cisterns that overflow to drywells. In general, the primary function of cisterns is to capture and store rooftop runoff that can be used at a later time. A drywell is a single infiltration chamber; in this case, it is intended to accept overflow from the cistern in larger rain events, or when the cistern is already full from a previous storm event. Both the cistern and the drywell help to reduce peak flows leaving the site, thus helping to meet channel protection and peak control requirements. Cisterns are only optional – since rooftop runoff does not need to be treated (**Volume I, Section 2.2.2.1**), it can discharge directly into the ground via drywells, with the volume counting towards both recharge and water quality requirements.



**Figure 4.19 Detail of Cistern and Drywell**



**Step 1: Compute the Water Quality Volume (WQ<sub>v</sub>) and Recharge Volume (Re<sub>v</sub>) using the Unified Stormwater Sizing Criteria**

**Recharge, Re<sub>v</sub>**

The site is located in the limestone region of the island (**Volume I, Figure 2.3**), so use P = 1.5 in.

$$\begin{aligned} \text{Re}_v &= [(P) (I) (A)] / 12 \\ &= [(1.5 \text{ in}) (0.32) (0.25 \text{ ac})] (1\text{ft}/12\text{in}) \\ &= \underline{0.01 \text{ ac-ft} = 436 \text{ ft}^3} \end{aligned}$$

**Water Quality Volume, WQ<sub>v</sub>**

Consult **Volume I, Figure 2.3** to determine the quality of the site. This site is in the highest quality resource area on Tinian, which falls under the 90% capture rule.

$$\begin{aligned} \text{WQ}_v &= [(P) (I) (A)] / 12 \\ &= [(1.5 \text{ in}) (0.32) (0.25 \text{ ac})] (1\text{ft}/12\text{in}) \\ &= \underline{0.01 \text{ ac-ft} = 436 \text{ ft}^3} \end{aligned}$$

**Step 2: Size the cistern and drywell.**

Cisterns are only optional, but for this example, they will be used as a supplemental water source for the house. There are several references to help homeowners size a cistern based on water needs for their house, including the following:

Sizing: Heitz LF, Winter SJ. Designing Your Rainwater Catchment and Storage System. Water and Energy Research Institute of the Western Pacific, University of Guam, Water Information Bulletin No. 1, March 1996.

Design & construction: Macomber PSH. Guidelines on Rainwater Catchment Systems for Hawaii. College of Tropical Agriculture and Human Resources, University of Hawaii at Manoa. 2004.

For this example, two cisterns (see **Figure 4.18**) will be sized to handle the recharge runoff volume from the house roof using the following equation recommended by the Low Impact Development Center, Inc. (<http://www.lid-stormwater.net>):

$$\text{Vol} = A * P * 0.90 * 7.5 \text{ gals/ ft}^3$$

Where:

- Vol = Volume of rain barrel or cistern (gallons)
- A = Impervious surface area draining into cistern (ft<sup>2</sup>)
- P = Precipitation (ft)
- 0.90 = fraction of total volume used by system (unitless)
- 7.5 = conversion factor (gallons per ft<sup>3</sup>)

The total roof area draining to the cisterns is 2,300 ft<sup>2</sup>, and the 90% capture rule should be used for the recharge and water quality requirement (P = 1.5 in = 0.125 ft).

Thus,  $\text{Vol} = (2,300 \text{ ft}^2) (0.125 \text{ ft}) (0.90) (7.5) = 1,941$  gallons required. Divide by 2 since flow will be diverted to two cisterns – 970.5 gallons. Thus, use two (2) 1,000-gallon tanks with an overflow to a drywell for recharge.

The drywell can be sized by following the step-by-step infiltration chamber example in **Section 4.3**.

### Step 3: Select additional BMPs to treat runoff from the site.

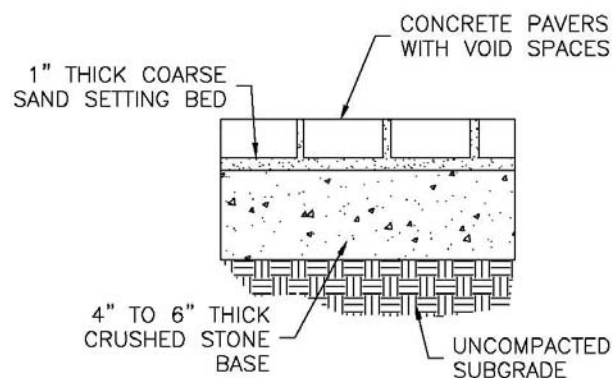
There are many structural and non-structural ways that a single-family home can meet stormwater requirements. For an in-depth look at better site design, please refer to **Chapter 3**. Some structural BMPs that could be utilized for this site are shown in **Figure 4.17** and described below.

#### 4.4.2 Rain Garden

A rain garden is a type of bioretention facility that can be designed to intercept flow associated with a single family home. The step-by-step example in **Section 4.2.1** shows how the water quality and recharge requirements can be met by rain garden. In general, rain gardens are smaller versions of bioretention systems, and are designed to provide water quality treatment, recharge, and in some instances peak flow controls. In this particular example, the rain garden is treating runoff from the yard and paved areas, although rain gardens can also be designed to capture rooftop runoff.

#### 4.4.3 Permeable Pavers

Permeable pavers (as described in **Section 3.6**) can be used in the driveway and walkway areas associated with the single family home. In general, permeable pavers are designed to promote recharge and decrease peak flows. **Figure 4.20** is a typical detail for permeable pavers. For more information on specifications and installation, visit the Interlocking Concrete Pavement Institute at <http://www.icpi.org/>.



**Figure 4.20** Detail of Permeable Pavers

#### 4.4.4 Swale

A dry swale can be used along the road to collect the overflow from the rain garden, driveway, and walkways. Dry swales can help meet recharge, water quality, and water quantity requirements for the site. See **Section 4.1.2** for a detailed design example.



## 5.0 Landscaping Guidance

Landscaping is a critical element to improve both the function and appearance of stormwater best management practices (BMPs). This chapter provides landscaping criteria and plant selection guidance for effective stormwater BMPs. It is organized as follows:

The first section, **5.1**, outlines general guidance that should be considered when landscaping any stormwater practice. **Sections 5.2-5.5** then present more specific guidance on landscaping criteria and plant selection for individual BMP designs. These include:

- Stormwater ponds and wetlands
- Infiltration and sand filter practices
- Bioretention
- Open Channels
- Filter Strips and Buffers

In **Section 5.6**, key factors in selecting plant material for stormwater landscaping are reviewed, including hardiness zones, physiographic regions, hydrologic zones, and cultural factors.

### *Native Species*

This manual encourages the use of native plants in stormwater management facilities. Native plants are defined as those species which evolved naturally to live in this region of the world. Practically speaking, this refers to those species which lived on the islands before recent human settlement. Many introduced species were weeds brought in by accident; others were intentionally introduced and cultivated for use as food, medicinal herbs, spices, dyes, fiber plants, and ornamentals.

Introduced species can often escape cultivation and begin reproducing in the wild. This is significant ecologically because many introduced species out-compete indigenous species and begin to replace them in the wild. Some introduced species like tangam-tangam, water-hyacinth, and sugar cane are invasive, have few predators, and can take over naturally occurring species at an alarming rate. By planting native species in stormwater management facilities, we can help protect the natural heritage of CNMI and Guam and provide a legacy for future generations.

Native species also have distinct genetic advantages over non-native species for planting in CNMI and Guam. Because they have evolved to live here naturally, indigenous plants are best suited for the local climate. This translates into greater survivorship when planted and less

replacement and maintenance during the life of a stormwater management facility. Both of these attributes provide cost savings for the facility owner.

Finally, people often plant exotic species for their ornamental value. While it is important to have aesthetic stormwater management facilities for public acceptance and the maintenance of property value, it is not necessary to introduce foreign species for this purpose. Many native species are aesthetically pleasing and can be used as ornamentals. When selecting ornamentals for stormwater management facilities, planting preference should be given to native ornamentals.



## 5.1 General Landscaping Guidance for All Stormwater BMPs

- Do not plant trees and shrubs within 15 ft of the toe of slope of a dam.
- Do not plant trees or shrubs known to have long tap roots within the vicinity of the earth dam or subsurface drainage facilities.
- Do not plant trees and shrubs within 15 ft of perforated pipes.
- Do not plant trees and shrubs within 25 ft of a hydraulic outlet control structure.
- Provide 15-ft clearance from a non-clogging, low-flow orifice.
- Herbaceous embankment plantings should be limited to 10 inches in height, to allow visibility for the inspector who is looking for burrowing rodents that may

compromise the integrity of the embankment.

- Provide slope stabilization methods for slopes steeper than 2:1, such as planted erosion control mats. Also, use seed mixes with quick germination rates in this area. Augment temporary seeding measures with container crowns or root mats of more permanent plant material.
- Utilize erosion control mats and fabrics to protect in channels that are subject to frequent wash outs.
- Stabilize all water overflows with plant material that can withstand strong current flows. Root material should be fibrous and substantial but lacking a tap root.
- Divert flows temporarily from seeded areas until stabilized.
- Check water tolerances of existing plant materials prior to inundation of area.
- Stabilize aquatic and safety benches with emergent wetland plants and wetland seed mixes.
- Do not block maintenance access to structures with trees or shrubs.
- Avoid plantings that will require routine or intensive chemical applications (i.e. turf area).
- Have soil tested to determine if there is a need for amendments.
- Select plants that can thrive with on-site soil with no additional amendments or a minimum of amendments.



- Decrease the areas where turf is used. Use low-maintenance ground cover to absorb run-off.
- Plant stream and edge of water buffers with trees, shrubs, ornamental grasses, and herbaceous materials where possible, to stabilize banks and provide shade.
- Maintain and frame desirable views. Be careful not to block views at entrances, exits, or difficult road curves. Screen or buffer unattractive views into the site.
- Use plants to prohibit pedestrian access to pools or steeper slopes that may be unsafe.
- The designer should carefully consider the long-term vegetation management strategy for the BMP, keeping in mind the “maintenance” legacy for the future owners. Keep maintenance area open to allow future access for pond maintenance. Provide a planting surface that can withstand the compaction of vehicles using maintenance access roads. Make sure the facility maintenance agreement includes a maintenance requirement of designed plant material.
- Provide Signage for:
  - Stormwater Management Areas to help educate the public when possible.
  - Wildflower areas, when possible, to designate limits of mowing.
- Avoid the overuse of any plant materials.
- Preserve existing natural vegetation when possible.

It is often necessary to test the soil in which you are about to plant in order to determine the following:

- pH; whether acid, neutral, or alkali
- major soil nutrients; Nitrogen, Phosphorus, Potassium
- minerals; such as chelated iron, lime

Have soil samples analyzed by experienced and qualified individuals, such as those at the Pacific Basin Natural Resources Conservation Service (NRCS), who will explain in writing the results, what they mean, as well as what soil amendments would be required. Certain soil conditions, such as marine clays or volcanic soils, can present serious constraints to the growth of plant materials and may require the involvement of qualified professionals. When poor soils cannot be amended, seed mixes and plant material must be selected to establish ground cover as quickly as possible.

Areas that have recently been involved in construction can become compacted so that plant roots cannot penetrate the soil. Seeds lie on the surface of compacted soils, allowing seeds to be washed away or be eaten by birds. Soils should be loosened to a minimum depth of two inches, preferably to a 4-inch depth. Hard soils may require discing to a deeper depth. The soil should be loosened regardless of the ground cover. This will improve seed contact with the soil, providing greater germination rates, allowing the roots to penetrate into the soil. Weak or patchy crops can be prevented by providing good growing conditions.

Whenever possible, topsoil should be spread to a depth of 4 inches (2-inch minimum) over the entire area to be planted. This provides organic matter and important nutrients for the plant material. This also allows the stabilizing materials to become established faster, while the roots are able to penetrate deeper and stabilize the soil, making it less likely that the plants will wash out during a heavy storm.

If topsoil has been stockpiled in deep mounds for a long period of time, it is desirable to test the soil for pH as well as microbial activity. If the microbial activity has been destroyed, it is necessary to inoculate the soil after application.

Remember that newly installed plant material requires water in order to recover from the shock of being transplanted. Be sure that some source of water is provided, should dry periods occur after the initial planting. This will reduce plant loss and provide the new plant materials with a chance to establish root growth.



## 5.2 Ponds and Wetlands

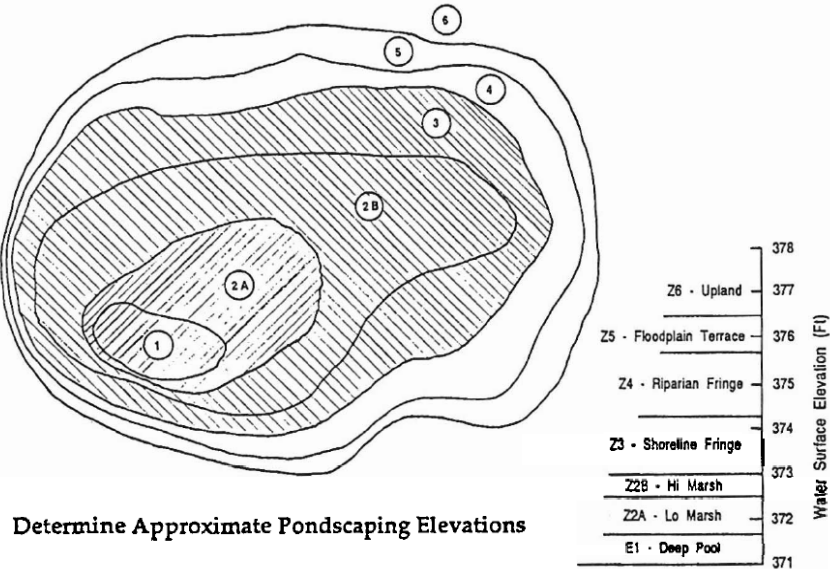
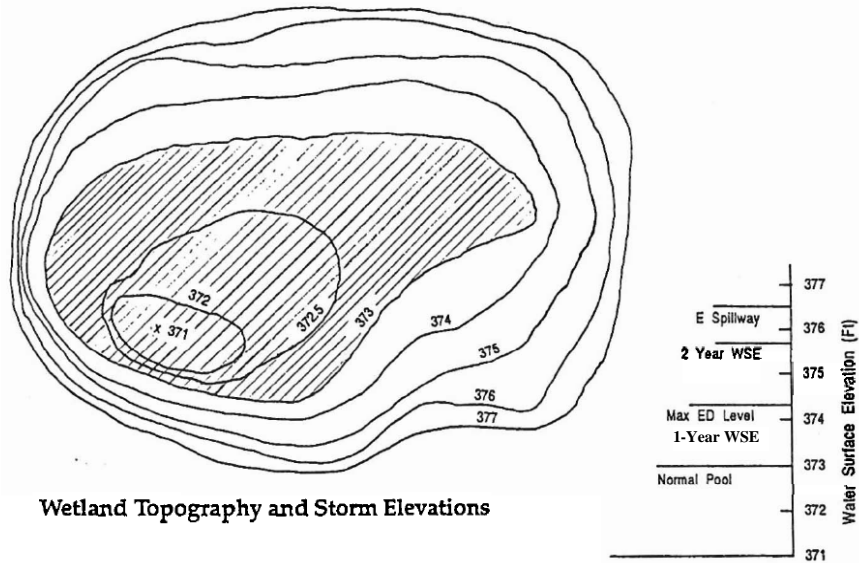
For areas that are to be planted within a stormwater management facility, it is necessary to determine what type of hydrologic zones will be created within the facility. The following six zones describe the different conditions encountered in stormwater management facilities. Every facility does not necessarily incorporate all of these zones. The hydrologic zones designate the degree of tolerance the plant exhibits to differing degrees of inundation by water.

Each zone has its own set of plant selection criteria based on the hydrology of the zone, the stormwater functions required of the plant and the desired landscape effect. The hydrologic zones are described in **Table 5.1** and illustrated in **Figure 5.1**.

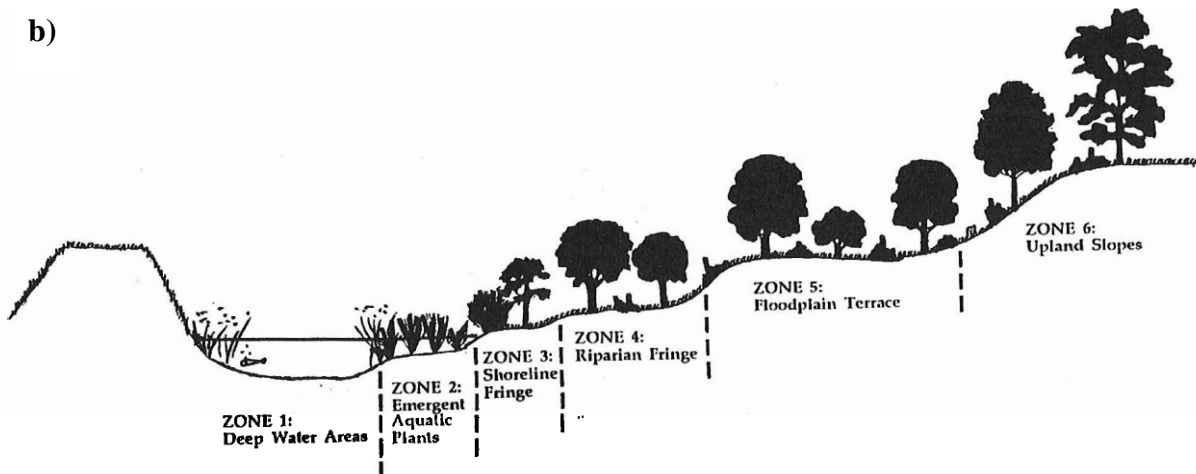
**Table 5.1 Hydrologic Zones**

<b><u>Zone #</u></b>	<b><u>Zone Description</u></b>	<b><u>Hydrologic Conditions</u></b>
<b>Zone 1</b>	Deep Water Pool	1-6 feet deep Permanent Pool
<b>Zone 2</b>	Shallow Water Bench	6 inches to 1 foot deep
<b>Zone 3</b>	Shoreline Fringe	Regularly inundated
<b>Zone 4</b>	Riparian Fringe	Periodically inundated
<b>Zone 5</b>	Floodplain Terrace	Infrequently inundated
<b>Zone 6</b>	Upland Slopes	Seldom or never inundated

a)



b)



**Figure 5.1 Planting Zones for Stormwater Ponds and Wetlands as they appear in a) plan view and b) cross-section (Schueler, 1992).**



### Zone 1: Deep Water Area (1 - 6 Feet)

Ponds and wetlands both have deep pool areas that comprise Zone 1. These pools range from one to six feet in depth, and are best colonized by submergent plants, if at all.

This pondscaping zone has not been routinely planted for several reasons. First, the availability of plant materials that can survive and grow in this zone is limited, and it is also feared that plants could clog the stormwater facility outlet structure. In many cases, these plants will gradually become established through natural recolonization (e.g., transport of plant fragments from other ponds via the feet and legs of waterfowl). If submerged plant material becomes more commercially available and clogging concerns are addressed, this area can be planted. The function of the planting is to reduce resedimentation and improve oxidation while creating a greater aquatic habitat.

- Plant material must be able to withstand constant inundation of water of one foot or greater in depth.
- Plants may be submerged partially or entirely.
- Plants should be able to enhance pollutant uptake.
- Plants may provide food and cover for waterfowl, desirable insects, and other aquatic life.

### Zone 2: Shallow Water Bench (Normal Pool to 1 Foot)

Zone 2 includes all areas that are inundated below the normal pool to a depth of one foot, and is the primary area where emergent plants will grow in stormwater wetlands. Zone 2 also coincides with the aquatic bench found in stormwater ponds. This zone offers ideal conditions for the growth of many emergent wetland species. These areas may be located at the edge of the pond or on low mounds of earth located below the surface of the water within the pond. When planted, Zone 2 can be an important habitat for many aquatic and nonaquatic animals, creating a diverse food chain. This food chain includes predators, allowing a natural regulation of mosquito populations, thereby reducing the need for insecticidal applications.

- Plant material must be able to withstand constant inundation of water to depths between six inches and one foot deep.
- Plants will be partially submerged.
- Plants should be able to enhance pollutant uptake.
- Plants may provide food and cover for waterfowl, desirable insects and other aquatic life.

Plants will stabilize the bottom of the pond, as well as the edge of the pond, absorbing wave impacts and reducing erosion, when water level fluctuates. Plant also slow water velocities and increase sediment deposition rates. Plants can reduce resuspension of sediments caused by the wind. Plants can also soften the engineered contours of the pond, and can conceal drawdowns during dry weather.



### Zone 3: Shoreline Fringe (*Regularly Inundated*)

Zone 3 encompasses the shoreline of a pond or wetland, and extends vertically about one foot in elevation from the normal pool. This zone includes the safety bench of a pond, and may also be periodically inundated if storm events are subject to extended detention. This zone occurs in a wet pond or shallow marsh and can be the most difficult to establish since plants must be able to withstand inundation of water during storms, when wind might blow water into the area, or the occasional drought during the summer. In order to stabilize the soil in this zone, Zone 3 must have a vigorous cover.

- Plants should stabilize the shoreline to minimize erosion caused by wave and wind action or water fluctuation.
- Plant material must be able to withstand occasional inundation of water. Plants will be partially submerged partially at this time.
- Plant material should, whenever possible, shade the shoreline, providing cover for wildlife.
- Plants should be able to enhance pollutant uptake.
- Plants may provide food and cover for waterfowl, songbirds, and wildlife. Plants could also be selected and located to control overpopulation of waterfowl.
- Plants should be located to reduce human access, where there are potential hazards, but should not block the maintenance access.
- Plants should have very low maintenance requirements, since they may be difficult or impossible to reach.
- Plants should be resistant to disease and other problems which require chemical applications (since chemical application is not advised in stormwater ponds).

### Zone 4: Riparian Fringe (*Periodically Inundated*)

Zone 4 extends from one to four feet in elevation above the normal pool. Plants in this zone are subject to periodic inundation after storms, and may experience saturated or partly saturated soil inundation. Nearly all of the temporary extended detention area is included within this zone.

- Plants must be able to withstand periodic inundation of water after storms, as well as occasional drought during the dry season.
- Plants should stabilize the ground from erosion caused by uphill run-off.
- Plants should shade the low-flow channel.
- Plants should be able to enhance pollutant uptake.
- Plant material should have very low maintenance, since they may be difficult or impossible to access.
- Plants may provide food and cover for waterfowl, songbirds and wildlife. Plants may also be selected and located to control overpopulation of waterfowl.
- Plants should be located to reduce pedestrian access to the deeper pools.

### Zone 5: Floodplain Terrace (*Infrequently Inundated*)

Zone 5 is periodically inundated by flood waters that quickly recede in a day or less. Operationally, Zone 5 extends from the maximum one year or  $C_{p_v}$  water surface elevation

(WSE) up to the 25-year maximum WSE. Key landscaping objectives for Zone 5 are to stabilize the steep slopes characteristic of this zone and to establish a low maintenance, natural vegetation area.

- Plant material should be able to withstand occasional but brief inundation during storms, although typical moisture conditions may be moist, slightly wet, or even swing entirely to drought conditions during the dry season.
- Plants should stabilize the basin slopes from uphill erosion.
- Ground cover should be very low maintenance, since they may be difficult to access on steep slopes or if frequency of mowing is limited. A dense tree cover may help reduce maintenance and discourage nuisance wildlife.
- Plants may provide food and cover for waterfowl, songbirds, and wildlife.
- Placement of plant material in Zone 5 is often critical, as it often creates a visual focal point and provides structure and shade for a greater variety of plants.

#### Zone 6: Upland Slopes (*Seldom or Never Inundated*)

The last zone extends above the maximum 25-year WSE, and often includes the outer buffer of a pond or wetland. Unlike other zones, this upland area may have sidewalks, bike paths, retaining walls, and maintenance access roads. Care should be taken to locate plants so they will not overgrow these routes or create hiding places that might make the area unsafe.

- Plant material is capable of surviving the particular conditions of the site. Thus, it is not necessary to select plant material that will tolerate any inundation. Rather, plant selections should be made based on soil condition, light, and function within the landscape.
- Groundcovers should emphasize infrequent mowing to reduce the cost of maintaining this landscape.
- Placement of plants in Zone 6 is important since they are often used to create a visual focal point, frame a desirable view, screen undesirable views, serve as a buffer, or provide shade to allow a greater variety of plant materials. Particular attention should be paid to seasonal color and texture of these plantings.

### 5.3 Infiltration and Sand Filters

Infiltration systems include Infiltration Trenches/Chambers (I-1) and Infiltration Basins (I-2). Filter systems include sand and organic filters (F-1 and F-2). Bioretention systems (F-3) are discussed in **Section 5.4**. Properly planted, these systems blend into natural surroundings. If unplanted or improperly planted, they can become eyesores and liabilities.

Design Constraints:

- Do not plant trees or provide shade within 15 ft of infiltration or filtering area or where leaf litter will collect and clog infiltration area.
- Have the soil tested in filtering bed to determine if there is a need for soil amendments.
- Determine depth of water table to determine standing water conditions and depth to constant soil moisture.
- Planting turf over sand filters is allowed with prior approval of the reviewing public agency, on a case-by-case basis.
- Do not locate plants to block maintenance access to structures.
- Divert flows temporarily from seeded areas until stabilized.
- Planting of peat filters or any filter requiring a filter fabric should include material selected with care to insure that no tap roots will penetrate the filter fabric.

### 5.4 Bioretention

#### *Planting Soil Bed Characteristics*

The characteristics of the soil for the bioretention facility are perhaps as important as the facility location, size, and treatment volume. The soil must be permeable enough to allow runoff to filter through the media, while having characteristics suitable to promote and sustain a robust vegetative cover crop. In addition, much of the nutrient pollutant uptake (nitrogen and phosphorus) is accomplished through adsorption and microbial activity within the soil profile. Therefore, the soils must balance soil chemistry and physical properties to support biotic communities above and below ground.

The planting soil should be a sandy loam, loamy sand, loam (USDA), or a loam/sand mix (should contain ~80% sand, by volume). Crushed limestone that is washed and meets the technical specification of ASTM C-33 is an acceptable substitute. The clay content for these soils should be less than 2% by volume. A permeability of at least 1.0 ft/day (0.5in/hr) is required. The soil should be free of stones, stumps, roots, other woody material over 1 in diameter, or brush/seeds from noxious weeds. Placement of the planting soil should be in lifts of 12 to 18in, loosely compacted (tamped lightly with a dozer or backhoe bucket). The specific characteristics are presented in **Table 5.2**.

**Table 5.2 Planting Soil Characteristics**

Parameter	Value
PH range	5.2 to 7.00
Organic matter*	0 to 20%
Magnesium	35 lbs. per acre, minimum
Phosphorus (P <sub>2</sub> O <sub>5</sub> )	75 lbs. per acre, minimum
Potassium (K <sub>2</sub> O)	85 lbs. per acre, minimum
Soluble salts	500 ppm
Clay	0 to 2%
Silt	0 to 20%
Sand (crushed, washed limestone)**	~80%

\*Organic matter shall consist of well-aged ( $\geq 3$  months) leaf compost created in a well-aerated atmosphere.

\*\*See bioretention construction specifications in **Section 6.4**.

### *Mulch Layer*

The mulch layer plays an important role in the performance of the bioretention system. The mulch layer helps maintain soil moisture and avoids surface sealing which reduces permeability. Mulch helps prevent erosion, and provides a micro-environment suitable for soil biota at the mulch/soil interface. It also serves as a pretreatment layer, trapping the finer sediments which remain suspended after the primary pretreatment.

The mulch layer should be standard landscape style, single or double, shredded tangantangan or coconut mulch or chips. The mulch layer should be well aged (stockpiled or stored for at least six (6) months), uniform in color, and free of other materials, such as weed seeds, soil, roots, etc. The mulch should be applied to a maximum depth of three inches. Grass clippings should not be used as a mulch material.

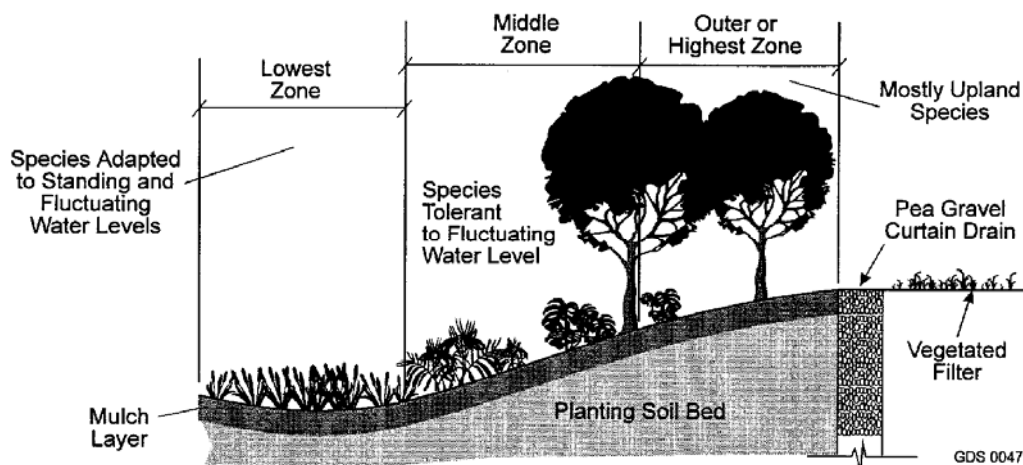
### *Planting Plan Guidance*

Plant material selection should be based on the goal of simulating a terrestrial forested community of native species. Bioretention simulates an ecosystem consisting of an upland-oriented community dominated by trees, but having a distinct community, or sub-canopy, of understory trees, shrubs and herbaceous materials. The intent is to establish a diverse, dense plant cover to treat stormwater runoff and withstand urban stresses from insect and disease infestations, drought, temperature, wind, and exposure.

The proper selection and installation of plant materials is key to a successful system. There are essentially three zones within a bioretention facility (**Figure 5.2**). The lowest elevation supports plant species adapted to standing and fluctuating water levels. The middle elevation supports a

slightly drier group of plants, but still tolerates fluctuating water levels. The outer edge is the highest elevation and generally supports plants adapted to dryer conditions.

The layout of plant material should be flexible, but should follow the general principals described in **Table 5.3**. As stated in **Volume I, Section 3.2.4.4**, tree density of approximately one tree per 100 ft<sup>2</sup> (i.e., 10 ft on-center) is recommended. Shrubs and herbaceous vegetation should generally be planted at higher densities (5 ft on-center and 2.5 ft on center, respectively). The objective is to have a system which resembles a random and natural plant layout, while maintaining optimal conditions for plant establishment and growth.



**Figure 5.2 Planting Zones for Bioretention Facilities**

**Table 5.3 Planting Plan Design Considerations**

Native plant species should be specified over exotic or foreign species.
Appropriate vegetation should be selected based on the zone of hydric tolerance
Species layout should generally be random and natural.
A canopy should be established with an understory of shrubs and herbaceous materials.
Woody vegetation should not be specified in the vicinity of inflow locations.
Trees should be planted primarily along the perimeter of the bioretention area.
Urban stressors (e.g., wind, sun, exposure, insect and disease infestation, drought) should be considered when laying out the planting plan.
Noxious weeds should not be specified.
Aesthetics and visual characteristics should be a prime consideration.
Traffic and safety issues must be considered.
Existing and proposed utilities must be identified and considered.

### *Plant Material Guidance*

Plant materials should conform to the American Standard Nursery Stock, published by the American Association of Nurserymen, and should be selected from certified, reputable nurseries. Planting specifications should be prepared by the designer and should include a sequence of construction, a description of the contractor's responsibilities, a planting schedule and installation specifications, initial maintenance, and a warranty period and expectations of plant survival.

**Table 5.4** presents some typical issues for planting specifications.

**Table 5.4 Planting Specification Issues for Bioretention Areas**

Specification Element	Elements
Sequence of Construction	Describe site preparation activities, soil amendments, etc.; address erosion and sediment control procedures; specify step-by-step procedure for plant installation through site clean-up.
Contractor's Responsibilities	Specify the contractor's responsibilities, such as watering, care of plant material during transport, timeliness of installation, repairs due to vandalism, etc.
Planting Schedule and Specifications	Specify the materials to be installed, the type of materials (e.g., B&B, bare root, containerized); time of year of installations, sequence of installation of types of plants; fertilization, stabilization seeding, if required; watering and general care.
Maintenance	Specify inspection periods; mulching frequency (annual mulching is most common); removal and replacement of dead and diseased vegetation; treatment of diseased trees; watering schedule after initial installation (once per day for 14 days is common); repair and replacement of staking and wires.
Warranty	Specify the warranty period, the required survival rate, and expected condition of plant species at the end of the warranty period.

## 5.5 Open Channels

Consult **Table 5.5** for grass species that perform well in the stressful environment of an open channel.

**Table 5.5 Common Grass Species for Dry and Wet Swales and Grass Channels used in Guam and CNMI**

Common Name	Scientific Name
Carpet grass	<i>Axonopus affinis</i>
Bermuda grass	<i>Cynodon dactylon</i>
Pangola grass	<i>Digitaria decumbens</i>
Centipede grass	<i>Eremochloa ophiuroides</i>
Tropic lalo paspalum	<i>Paspalum hieronymelii</i>
Bahia grass	<i>Paspalum notatum</i>

## 5.6 Other Considerations in Stormwater BMP Landscaping

### *Use or Function*

In selecting plants, consider their desired function in the landscape. Is the plant needed as ground cover, soil stabilizer, or a source of shade? Will the plant be placed to frame a view, create focus, or provide an accent? Does the adjacent use provide conflicts or potential problems and require a barrier, screen, or buffer? Nearly every plant and plant location should be provided to serve some function in addition to any aesthetic appeal.

### *Plant Characteristics*

Certain plant characteristics are so obvious that they may actually be overlooked in the plant selection. These are:

- Size
- Shape

For example, tree limbs, after several years, can grow into power lines. A wide-growing shrub may block an important line of sight to oncoming vehicular traffic. A small tree could strategically block the view from a second-story window. Consider how these characteristics can work for you or against you, today and in the future.

Other plant characteristics must be considered to determine whether the plant will fit with the landscape today and through the years to come. Some of these characteristics are:

- Color
- Texture
- Aesthetic Interest, i.e.- Flowers, Fruit, Leaves, Stems/Bark
- Growth rate

In urban or suburban settings, residents living next to a stormwater system may desire that the facility be appealing or interesting. Aesthetics is an important factor to consider in the design of these systems. Failure to consider the aesthetic appeal of a facility to the surrounding residents may result in reduced value to nearby lots. Careful attention to the design and planting of a facility can result in maintained or increased values of a property and long-term benefits to the reputation of the designer.

### *Availability and Cost*

Often overlooked in plant selection is the availability from wholesalers and the cost of the plant material. There are many plants listed in landscape books that are not readily available from the nurseries. Without knowledge of what is available, time spent researching and finding the one plant that meets all the needs will be wasted, if it is not available from the growers. It may require shipping, therefore, making it more costly than the budget may allow. Some planting requirements may require a special effort to find the specific plant that fulfills the needs of the site and the function of the plant in the landscape.

**<This page left blank intentionally>**





## ***6.0 BMP Sample Design and Construction Specifications***

The following sections provide standards and specifications for the design and construction of the acceptable stormwater treatment practices described in **Volume I, Chapter 3**. In addition, a construction checklist is provided with each construction specification.

### **6.1 Design Specification for Embankments**

#### **DEFINITION**

A pond is a water impoundment made by constructing a dam or an embankment or by excavating a pit or dugout.

In this standard, ponds constructed by the first method are referred to as embankment ponds, and those constructed by the second method are referred to as excavated ponds. Ponds constructed by both excavation and the embankment methods are classified as embankment ponds if the depth of water impounded against the embankment at the principal spillway storm design high water elevation is 3 feet or more (See **Table 6.1**).

These 3 feet shall be measured from the low point on the upstream toe of the embankment to the design high water.

#### **PURPOSE**

To provide water for livestock, fish and wildlife, recreation, fire control, crop and orchard spraying, and other related uses, and to maintain or improve water quality. This standard also applies to stormwater management ponds.

#### **CONDITIONS WHERE PRACTICE APPLIES**

**General** - This practice applies where it is determined that stormwater management, water supply, or temporary storage is justified and it is feasible and practicable to build a pond which will meet local and federal law requirements.

**Note:** This document was adapted from Maryland Code 378 Pond Specifications. Conservation practice standards are reviewed periodically, and updated if needed. To obtain the current version of this standard, contact the Natural Resources Conservation Service.

This standard establishes the minimum acceptable quality for the design and construction of ponds if:

1. Failure of the dam will not result in loss of life; in damage to homes, commercial or industrial buildings, main highways, or railroads; or interruption of the use or service of public utilities.
2. The product of the storage times the effective height of the dam is less than 3,000. Storage is the volume, in acre-feet, in the reservoir below the elevation of the crest of the emergency spillway.

The effective height of the dam is the difference in elevation, in feet, between the emergency spillway crest and the lowest point on a profile taken along the centerline of the dam, excluding the cutoff trench. If there is no emergency spillway, the top of the dam becomes the upper limit for determining the storage and the effective height.

3. For dams in rural areas, the effective height of the dam (as defined above) is 35 feet or less and the dam is hazard class “a”. For dams in urban areas, the effective height of the dam is 20 feet or less and the dam is hazard class “a”.

Ponds exceeding any of the above conditions shall be designed and constructed according to the requirements of Technical Release 60.

***Exemptions*** - Soil Conservation District small pond approval is not required for small class “a” structures where the following exists:

1. Ponds or other structures have less than four (4) feet of embankment, or
2. The storage at emergency spillway design high water elevation according to **Table 6.1** does not exceed 40,000 ft<sup>3</sup>, and the height of the embankment is 6 ft or less.

The height of the embankment shall be measured from the top of the dam to the lowest point of excavation, excluding the cutoff trench, along the centerline of the dam.

In addition, an embankment pond that meets the criteria below shall be considered an excavated pond and is also exempt from small pond approval.

1. The calculation of  $10H+20=L$ , where H=height from the pond bottom to the top of the dam, is provided, and
2. The projection of L horizontally downstream from the pond bottom is below the existing or proposed ground, and
3. The existing or proposed downstream ground slope within the projection of L is less than 10% at any point.

The review and design of such class “a” structures shall be based on sound engineering judgment assuring a stable outfall for the ten (10) year, 24-hour storm event.

**Site Conditions** - Site Conditions shall be such that runoff from the design storm can be safely passed through (1) a natural or constructed emergency spillway, (2) a combination of a principal spillway and an emergency spillway, or (3) a principal spillway.

**Drainage Area** - The drainage area above the pond must be protected against erosion to the extent that expected sedimentation will not shorten the planned effective life of the structure.

For ponds whose primary purpose is to trap sediment for water quality, adequate storage should be provided to trap the projected sediment delivery from the drainage area for the life of the pond.

If the intent is to maintain a permanent pool, the drainage area should be at least 4 acres for each acre-foot of permanent storage. These recommendations may be reduced if a dependable source of ground water or diverted surface water contributes to the pond. The water quality shall be suitable for its intended use.

**Soils Investigation** - A soils investigation is required on all ponds. As a minimum it shall include information along the centerline of the proposed dam, in the emergency spillway location, and the planned borrow area. The type of equipment used and the extent of the investigation will vary from site to site.

**Road Embankments** - Where road embankments are being designed to impound a specific volume of water, either as a permanent pool or temporary stormwater storage, special design and evaluation criteria may be required as determined by the local regulating authority.

## **CONSIDERATIONS**

**Water Quantity** - The following items should be considered for water quantity:

1. Effects upon components of the water budget, especially effects on volumes and rates of runoff, infiltration, evaporation, transpiration, deep percolation, and ground water recharge.
2. Variability of effects caused by seasonal or climatic changes.
3. Effects on the downstream flows or aquifers that could affect other water uses or users.
4. Potential for multiple use.
5. Effects on the volume of downstream flow to prohibit undesirable environmental, social or economic effects.

**Water Quality** - The following items should be considered for water quality:

1. Effects on erosion and the movement of sediment, pathogens, and soluble and sediment attached substances that are carried by runoff.
2. Effects on the visual quality of on-site and downstream water resources.

3. Short-term and construction-related effects of this practice on the quality of downstream water courses.
4. Effects of water level control on the temperatures of downstream waters to prevent undesired effects on aquatic and wildlife communities.
5. Effects on wetlands and water-related wildlife habitats.
6. Effects of water levels on soil nutrient processes such as plant nitrogen use or denitrification.
7. Effects of soil water level control on the soil chemistry, soil water, or downstream water.
8. Potential for earth moving to uncover or redistribute sulfidic bearing soils.

## **CRITERIA**

### **Embankment Ponds**

**Structure Hazard Classification** - Documentation of the classification of dams is required. Documentation is to include but is not limited to location and description of dam, configuration of the valley, description of existing development (houses, utilities, highways, railroads, farm or commercial buildings, and other pertinent improvements), potential for future development, and recommended classification. It is also to include results obtained from breach routings, if breach routings are used as part of the classification process. The class (“a”, “b”, and “c”) as contained in this document is related to the potential hazard to life and property that might result from a sudden major breach of the earth embankment. Structure classification and land use for runoff determination must take into consideration the anticipated changes in land use throughout the expected life of the structure. The classification of a dam is the responsibility of the designer, and subject to review and concurrence of the approving authority.

The classification of a dam is determined only by the potential hazard from failure, not by the criteria. Classification factors in the National Engineering Manual, as supplemented, are given below:

Class “a” - Structures located in rural, agricultural or urban areas dedicated to remain in flood tolerant usage where failure may damage non-inhabited buildings, agricultural land, floodplains or county roads.

Class “b” - Structures located in rural, agricultural, or urban areas where failure may damage isolated homes, main highways or minor railroads or cause interruption of use or service of relatively important public utilities.

Class “c” - Structures located where failure may cause loss of life or serious damage to homes, industrial and commercial buildings, important public utilities, main highways, or railroads.

“Rural areas” is defined as those areas in which residents live on farms, in unincorporated settlements, or in incorporated villages or small towns. It is where agriculture, including woodland activities, and extractive industries, including seafood harvesting, provides the primary employment base for residents and where such enterprises are dependent on local residents for labor.

Non-rural areas shall be classified as urban.

**Peak Breach Discharge Criteria** - Breach routings are used to help delineate the area potentially impacted by inundation should a dam fail and can be used to aid dam classification. The breach hydrograph is the outflow hydrograph attributed to the sudden release of water in reservoir storage. This is due to a dam breach during non-storm conditions.

Stream routings made of the breach hydrograph are to be based upon topographic data and hydraulic methodologies mutually consistent in their accuracy and commensurate with the risk being evaluated.

The minimum peak discharge of the breach hydrograph, regardless of the techniques used to analyze the downstream inundation area, is as follows:

$$Q_{\max} = 3.2 H_w^{2.5} \text{ where,}$$

$Q_{\max}$  = the peak breach discharge, cfs.

$H_w$  = depth of water at the dam at the time of failure, feet. This is measured to the crest of the emergency spillway or to design high water, if no emergency spillway exists. Use “nonstorm” conditions downstream of the dam.

Where breach analysis has indicated that only overtopping of downstream roads will occur, the following guidelines will be used:

<u>Class</u>	<u>Depth of Flow (d) ft.</u>
“a”	$d \leq 1.5$
“b” & “c”	$d > 1.5$

Use and importance of the roadway shall be considered when making a classification.

**Hydrology** - Principal and emergency spillways will be designed within the limitations shown on **Table 6.1**. The storm duration used shall be 24 hours except where TR-60 is specified. The pond shall be designed to safely pass the base flow along with volume and peak rates of runoff from design storms, specified in **Table 6.1**. All storm water management ponds shall be designed using urban criteria. This can be done by using principal and emergency spillways. The following shall be used to determine runoff rates and volumes:

1. NRCS “Engineering Field Handbook, Part 650” or;

2. NRCS, NEH, Section 4, Hydrology” or;
3. NRCS, TR-55, “Urban Hydrology for Small Watersheds” or;
4. NRCS, TR-20, “Computer Program for Project Formulation” or,
5. Computer programs using NRCS hydrology methods with identifiable inputs and outputs as approved by the reviewing agency.

### **Earth Embankment**

**Top Width** - The minimum top width of the dam is shown in **Table 6.2**. When the embankment top is to be used as a public road, the minimum width is to be 16 feet for one-way and 26 feet for two-way traffic. If the embankment is to be used for infrequent vehicle crossings, the minimum top width shall be 10 feet. Guardrails or other safety measures are to be used where necessary and are to meet the requirements of the responsible road authority.

**Side Slopes** - The combined upstream and downstream side slopes of the settled embankment shall not be less than five horizontal to one vertical (5:1) with neither slope steeper than 2:1. If the dam is used as a road crossing with a top width greater than 26 feet, then the combined side slopes of the settled embankment shall not be less than 4 horizontal to one vertical (4:1) with neither slope steeper than 2:1. Slopes must be designed to be stable in all cases, even if flatter side slopes are required.

**Earth Cuts** - If cuts in an existing fill or in natural ground are required for the rehabilitation of an existing pond spillway or the construction of a new pond, the slope of the bonding surfaces between the existing material in place and the fill to be placed shall not be steeper than a ratio of two horizontal to one vertical (2:1).

**Foundation Cutoff** - A cutoff trench of relatively impervious material shall be provided under the entire length of the dam and shall be located at or upstream from the centerline of the dam. The cutoff trench shall have a bottom width adequate to accommodate the equipment used for excavation, backfill and compaction operations, with the minimum width being 4 feet, and shall have side slopes no steeper than one horizontal to one vertical. Minimum depth shall be 4 feet.

**Impervious Core** - Any impervious core within the embankment shall be located at or upstream from the centerline of the dam, and shall extend up the abutments to the 25-year water surface elevation. The impervious core shall extend vertically from the cutoff trench up to the 25-year water surface elevation throughout the embankment.

**Seepage Control** - Seepage control is to be included: (1) if pervious layers are not intercepted by the cutoff; (2) if seepage from the abutments may create a wet embankment; (3) if the phreatic line intersects the downstream slope; or (4) if special conditions require drainage to insure a stable dam. The phreatic line shall be drawn on a 4:1 slope starting on the inside slope at the normal pool elevation. For stormwater management ponds, normal pool shall be considered as the 25-year water surface elevation.

Seepage may be controlled by (1) foundation abutment or embankment drains; (2) reservoir blanketing; or (3) a combination of these measures. Foundation drains may control seepage encountered in the cutoff trench during construction. These drains must be located downstream of the dam centerline and outside the limits of the proposed cutoff trench. All drains must be designed according to the section Principal Spillway, Conduit Piping and Seepage Control.

**Wave Erosion Protection** - Where needed to protect the face of the dam, special wave protection measures such as a bench, rock riprap, sand-gravel, soil cement or special vegetation shall be provided. (Reference NRCS Technical Releases 56 & 69)

**Freeboard** - The top elevation of the settled embankment shall be determined in accordance with minimum criteria established in **Table 6.1**.

**Allowance for Settlement** - The design height of the dam shall be increased by the amount needed to insure that the design top of fill elevation will be maintained after all settlement has taken place. This increase shall not be less than 5 percent, except where detailed soil testing and lab analyses indicate a lesser amount is adequate.

### **Principal Spillway**

**Capacity** - A conduit, with needed appurtenances, shall be placed under or through the dam, except where a weir type structure is used. The minimum capacity of the principal spillway shall be that required in **Table 6.1**.

**Crest Elevation of Inlet** - The crest elevation of the principal spillway shall be no less than 1.0 foot below the crest of the emergency spillway. The crest elevation is the invert elevation of the lowest opening 6 inches or larger in any direction.

The inlet or riser size for the pipe drops shall be such that the flow through the structure goes from weir-flow control to pipe-flow control without going into orifice-flow control in the riser. The inlets and outlets shall be designed and analyzed to function satisfactorily for the full range of flow and hydraulic head anticipated.

The riser shall be analyzed for flotation assuming all orifices and pipes are plugged. The factor of safety against flotation shall be 1.2 or greater.

**Pipe Conduits** - Pipe conduits under or through the dam shall meet the following requirements:

1. All pipes shall be circular in cross section except for cast-in-place reinforced concrete box culverts.
2. Pipe shall be capable of withstanding the external loading without yielding, buckling, or cracking.
3. Pipe strength shall be not less than those shown on **Tables 6.3, 6.4 and 6.5** for corrugated steel, aluminum, and plastic pipes and applicable ASTM's for other materials.

4. Where inlet or outlet flared sections are used, they shall be made from materials compatible with the pipe.
5. All pipe joints shall be made watertight by the use of flanges with gaskets, coupling bands with gaskets, bell and spigot ends with gaskets, or by welding. See Pond Construction Specifications in **Section 6.2** for details.
6. The joints between sections of pipe shall be designed to remain watertight after joint rotation and elongation caused by foundation consolidation.

The capacity of the pipe conduit shall be adequate to discharge long duration, continuous or frequent flows without flow through the emergency spillway. The diameter of the pipe shall be not less than 6 inches.

For dams 20 feet or less in effective height, the following pipe materials are acceptable: cast-iron, ductile iron, steel, corrugated steel or aluminum, concrete with rubber gaskets, plastic, and cast-in-place reinforced concrete box culverts. Plastic pipe that will be exposed to direct sunlight should be made of ultraviolet resistant materials and protected by coating or shielding. Connections of pipe to less flexible pipe or structures must be designed to avoid stress concentrations that could rupture the pipe.

For dams over 20 feet in effective height, conduits are to be reinforced concrete pipe, cast-in-place reinforced concrete box culverts, corrugated steel, ductile iron, welded steel or aluminum pipe. The maximum height of fill over any principal spillway steel, aluminum, or plastic pipe must not exceed 25 feet.

Concrete pipe shall have a concrete cradle extending up the sides of the pipe at least 50% of its outside diameter with minimum thickness of 6 inches. Where a concrete cradle is not needed for structural reasons, flowable fill may be used as described in **Section 6.2**. Gravel bedding is not permitted. Cantilever outlet sections, if used, shall be designed to withstand the cantilever load. Pipe supports shall be provided when needed. Other suitable devices such as plunge basin, stilling basin, impact basin, or rock riprap spreader should be used to provide a safe outlet. Cathodic protection is to be provided for welded steel and corrugated steel pipe where the need and importance of the structure warrant. Cathodic protection should normally be provided for corrugated steel pipe where the saturated soil resistivity is less than 4,000 ohms-cm or the pH is lower than 5. The National Handbook of Conservation Practices, Irrigation Water Conveyance, Steel Pipeline Standard (430-FF), provides criteria for cathodic protection of welded steel pipes.

**Multiple Conduits** - Where multiple conduits are used, there shall be sufficient space between the conduits and the installed anti-seep collars to allow for backfill material to be placed between the conduits by the earth moving equipment and for easy access by hand operated compaction equipment. This distance between conduits shall be equal to or greater than half the pipe diameter but not less than 2 feet.

**Conduit Piping and Seepage Control** - Seepage along pipe conduit spillways extending through the embankment shall be controlled by use of (1) anti-seep collars, or (2) filter and drainage diaphragm. Seepage control will not be required on pipes 6 inches in diameter or less.



Anti-seep collars shall be installed around all conduits through earth fills according to the following criteria:

1. Sufficient collars shall be placed to increase the seepage length along the conduit by a minimum of 15 percent of the pipe length located within the saturation zone.
2. The assumed normal saturation zone shall be determined by projecting a line at a slope (4) horizontal to (1) vertical from the point where the normal water elevation meets the upstream slope to a point where this line intersects the invert of the pipe conduit or bottom of the cradle, whichever is lower. For Stormwater Management ponds, the phreatic line starting elevation shall be the 25-year water elevation.
3. Maximum collar spacing shall be 14 times the required projection above the pipe. The minimum collar spacing shall be 5 times the required minimum projection.
4. Anti-seep collars should be placed within the saturated zone. In cases where the spacing limit will not allow this, at least one collar will be in the saturated zone.
5. All anti-seep collars and their connections to the conduit shall be watertight and made of material compatible with the conduit.
6. Collar dimensions shall extend a minimum of 2 feet in all directions around the pipe.
7. Anti-seep collars shall be placed a minimum of two feet from pipe joints except where flanged joints are used.
8. For pipes with concrete cradles, the projection shall be measured from the cradle.

Filter and drainage diaphragms are always recommended, but are required when the following conditions are encountered:

1. The pond requires design according to TR-60.
2. Embankment soils with high piping potential such as Unified Classes GM, SM, and ML.

Filter and drainage diaphragms shall be designed in accordance with procedures from NRCS TR-60, Earth Dams and Reservoirs, Section 6, Principal Spillways, as described below.

The drainage diaphragm shall usually consist of sand, meeting the fine concrete aggregate requirements (ASTM C-33). A design analysis shall be made using Part 633 of the National Engineering Manual, Chapter 26, Gradation Design of Sand and Gravel Filters.

The drainage diaphragm shall be a minimum of 3 ft thick and extend vertically upward and horizontally at least three times the conduit outside diameter or the width of the cradle, whichever is greater except that:

1. The vertical extension need be no higher than the maximum potential reservoir water level, and

2. The horizontal extension need be no further than 5 feet beyond the sides and slopes of any excavation made to install the conduit.
3. The minimum soil cover over any portion of the filter-drainage diaphragm measured normal to the nearest embankment surface shall be at least 2 feet.

It shall extend vertically downward at least 2 ft beneath the conduit outside diameter or bottom of the cradle, whichever is greater. The drainage diaphragm shall be located immediately downstream of the cutoff trench, approximately parallel to the centerline of the dam but no further upstream than the centerline of the dam.

The drainage diaphragm shall outlet at the embankment downstream toe, preferably using a drain backfill envelope continuously along the pipe to where it exits the embankment. Protecting drain fill from surface erosion will be necessary.

It is required that the outlet for the filter diaphragm is sized to safely discharge the design flow. Where a drain backfill envelope is used as the outlet, it is recommended that it be designed so the hydraulic head does not exceed the depth of the drain outlet. The exposed area of the drain outlet must also be protected from external attack such as surface erosion and slope instability due to horizontal seepage pressures. A weighted toe cover such as riprap can be effective if protected with a properly designed filter between the sand drain material and the riprap cover.

If pipe drain outlets are used, consideration must be given to the structural design of the conduit in resisting external loading and the design life of the pipe must be consistent with the design life of the dam and physical conditions of the site. Also, the pipe must be designed for capacity and size of perforations as outlined in NEH Part 633, Chapter 26 and Soil Mechanics Note 3. If the pipe corrodes, is crushed by exterior loading, or is otherwise damaged, the outlet of the filter diaphragm is lost and a piping failure may occur.

The design quantity (Q) used to size the outlet can be calculated by Darcy's Law,  $Q = kiA$  where:

$k$  = permeability of the embankment or drain outlet material (ft/day)

$i$  = hydraulic gradient where  $i = h/l$

$h$  = head differential (ft)

$l$  = seepage path (ft)

$A$  = area of flow (diaphragm or outlet) (ft<sup>2</sup>)

**Anti-vortex Devices** - Drop inlet spillways are to have adequate anti-vortex devices. Splitter type anti-vortex devices shall be placed in line with the barrel. An anti-vortex device is not required if weir control is maintained in the riser through all flow stages.

**Trash Racks** - All pipe and inlet structures shall have a trash rack. Openings for trash racks shall be no larger than 1/2 of the barrel conduit diameter, but in no case less than 6 inches.

Flush grates for trash racks are not acceptable. Inlet structures that have flow over the top shall have a non-clogging trash rack such as a hood-type inlet extending a minimum of 8 inches below the weir openings, which allows passage of water from underneath the trash rack into the riser.

For inlet structures with solid covered tops, the bottom of the cover slab must be set at an elevation to prevent orifice flow control before pipe flow control governs.

Low stage releases, where the opening is larger than 6 inches, shall have a non-clogging trash rack with openings no larger than half the low flow dimension.

For all low stage releases 6 inches or smaller in any direction, the emergency spillway design storm shall be routed assuming the release has failed, using storage and discharge only above the elevation of the next opening larger than 6 inches in all directions. This design storm routing shall not overtop the dam.

**Drain Pipe** - A pipe with a suitable valve shall be provided to drain the pool area, where needed for proper pond management. The principal spillway conduit may serve as a pond drain, when so located, to accomplish this function.

**Water Supply Pipes or Utilities** - All pipes through the dam shall have an inside diameter of not less than 1 1/4 inches. Pipes / utilities not parallel to the axis of the dam shall meet all principal spillway requirements (i.e. filter diaphragm, embankment soils, etc.). Pipes / utilities parallel to the axis of the dam shall be constructed with no granular bedding.

### **Earth Emergency Spillways**

Emergency spillways are provided to convey large flood flows safely past earth embankments. An emergency spillway must be provided for each dam, unless the principal spillway is large enough to pass the routed design hydrograph peak discharge and any trash without overtopping the dam. The only design that may be utilized without an emergency spillway is: a principal spillway with a cross-sectional area of 3 square feet or more and an inlet that will not clog, such as a hood-type inlet which allows passage of water from underneath the trash rack into the riser.

**Capacity** - The minimum capacity of emergency spillways shall be that required to pass the peak flow expected from a design storm of the frequency and duration shown in **Table 6.1** less any reduction creditable to conduit discharge and detention storage.

The emergency spillway shall (1) safely pass the storm design peak or (2) the storm runoff shall be routed through the reservoir. The routing shall start with the water surface at the elevation of the crest of the principal spillway, or at the water surface after 10 days drawdown, whichever is higher. The 10-day drawdown shall be computed from the crest of the emergency spillway or from the elevation that would be attained had the entire design storm been impounded, whichever is lower. Emergency spillways are to provide for passage of the design flow at a non-erosive velocity to a point downstream where the dam will not be endangered.

**Component Parts** - Earth spillways are open channels and usually consist of an inlet channel, level section, and an exit channel. The minimum difference in elevation between the crest of the emergency spillway and the settled top of dam shall be 2.0 feet.

**Cross-Section** - Earth spillways shall be trapezoidal and shall be located in undisturbed earth. The side slopes shall be stable for the material in which the spillway is to be constructed, but not steeper than 2:1. The emergency spillway shall have a bottom width of not less than 8 feet.

The inlet channel may be curved to fit existing topography; however, it should be flared to allow unrestricted flow to the level section. The level section should be located as near the centerline of dam as possible. The level section shall be 25 feet in length, and shall be rectangular or square.

Exit channel centerline shall be perpendicular to the level section downstream edge and must be straight for a distance beyond the downstream toe, so that discharges will not reach the earth embankment. The grade of the exit channel shall fall within the range established by discharge requirement and permissible velocities.

The crest of any “token” spillway will be located at or above the 25-year storm elevation in undisturbed earth and have a minimum depth of one foot and bottom width of 8 feet.

**Permissible Velocities** - Earth spillways shall be designed for non-erosive velocities through the control section and to a point downstream where the dam will not be endangered. The maximum permissible velocity for the grass and grass mixture to be used shall be approved by the local regulating authority.

**Infiltration / Water Quality Basins** – Ponds, either excavated or embankment, that are designed solely for infiltration or as water quality basins will have an emergency spillway. The capacity of the spillway will be determined by the following procedure:

Pass the routed 25-Year Storm with 1 foot of freeboard to the top of dam elevation. Routing will begin at the emergency spillway crest.

### **Structural Emergency Spillways**

Chutes or drops, when used for principal spillways or principal-emergency or emergency spillways, shall be designed in accordance with the principals set forth in the National Engineering Handbook, Section 5 “Hydraulics”; Section 11 “Drop Spillways”; and Section 14 “Chute Spillways”. The minimum capacity of a structural spillway shall be that required to pass the peak flow expected from a design storm of the frequency and duration shown in **Table 6.1** less any reduction creditable to conduit discharge and detention storage.

### **Visual Resource Design**

The visual design of ponds shall be carefully considered in areas of high public visibility and those associated with recreation. The underlying criterion for all visual design is appropriateness. The shape and form of ponds, excavated material, and plantings are to relate visually to their surroundings and to their functions.

The embankment may be shaped to blend with the natural topography. The edge of the pond should be shaped so that it is generally curvilinear rather than rectangular. Excavated material shall be shaped so that the final form is smooth, flowing, and fitting to the adjacent landscape

rather than angular geometric mounds. If feasible, islands may be added for visual interest and to attract wildlife.

### **Trees and Shrubs**

***Non-Roadway Embankments*** - Trees and/or shrubs will not be allowed on any embankment, will not be allowed within the buffer zone (15 feet from the toe of the dam), and will not be allowed within a 25-foot radius around the inlet structure.

***Roadway Embankments*** - Trees and/or shrubs will not be allowed on any embankment, except for dry stormwater management structures that will be utilized as a roadway under all the following conditions:

1. Plantings may only be on top of the dam along the roadway and/or sidewalks.
2. The top of the dam shall have a minimum of 50-foot top width.
3. Plantings will not be allowed on the side slopes of the embankment.
4. Plantings will not be allowed within the buffer zone (15 feet from the toe of the dam).
5. Plantings will only be shallow rooted (roots less than 3 feet deep) trees or shrubs.
6. The pond is a “dry” structure (normal pool not exceeding 18 inches).
7. A landscape plan showing type and location of planting must be prepared by a Landscape Architect certifying shallow rooted plants (roots less than 3 feet deep) under mature conditions.
8. A minimum of 3 feet freeboard above the 25-year water surface elevation must be maintained.
9. The structure is a low hazard (Class “a”) pond.

### **Safety**

Special considerations should be made for safety and access during the design of a pond. Measures to be considered may include fencing, slope benching, access roads, flattened side slopes, etc. When fencing a structure, the fence will be located so it will not interfere with the operation of the emergency spillway.

### **Excavated Ponds**

***General*** - Excavated ponds that create a failure potential through a constructed or created embankment will be designed as embankment ponds. Excavated ponds that include a pipe or weir outlet control system for urban stormwater management shall be designed using the principal and emergency spillway hydrologic criteria for Embankment Ponds, **Table 6.1**.

**Side Slopes** - Side slopes of excavated ponds shall be such that they will be stable and shall not be steeper than 1 horizontal to 1 vertical. Flatter slopes are to be utilized where safety for children, livestock watering, etc. is a design factor.

**Perimeter Form** - Where the structures are used for recreation or are located in high public view, the perimeter or edge should be shaped to a curvilinear form.

**Inlet Protection** - When the excavated pond is a bypass type and water is being diverted from a stream, the minimum size inlet line shall be a 4-inch diameter pipe. All Commonwealth (Territory) laws concerning water use and downstream rights shall be strictly adhered to.

Where surface water enters the pond in a natural or excavated channel, the side slope of the pond shall be protected against erosion.

**Outlet Protection** – An excavated pond with a low embankment (combination excavation / embankment pond) shall be designed to ensure a stable outfall for the 2-year, 24-hour frequency storm.

**Placement of Excavated Material** - The material excavated from the pond shall be placed in one of the following ways so that its weight will not endanger the stability of the pond side slopes and where it will not be washed back into the pond by rainfall:

1. Uniformly spread to a height not exceeding 3 feet with the top graded to a continuous slope away from the pond;
2. Uniformly placed or shaped reasonably well with side slopes no steeper than 2 to 1. The excavated material will be placed at a distance equal to the depth of the pond, but not less than 12 feet from the edge of the pond;
3. Shaped to a designed form that blends visually with the landscape;
4. Used for low embankment and leveling; or
5. Hauled away.

### **Reservoir Area for Wet Ponds**

For most ponds, the topography of the site shall permit storage of water at a depth and volume that ensures a dependable supply, considering beneficial use, sedimentation, season of use, and evaporation and seepage losses. Soils in the reservoir shall be impervious enough to minimize seepage losses or shall be of a type that sealing is practical.

Excavation and shaping required to permit the reservoir area to suitably serve the planned purpose shall be included in the construction plans.

Reservoirs designed specifically for fish production or wildlife management shall follow design criteria in the standards and specifications, as appropriate.

**Table 6.1 Hydrologic Criteria For Ponds**

Structure Class	Storage Height Product <sup>1</sup>	Watershed Area (Acres)	Height To Emergency Spwy Crest (Feet)	Normal Surface Area (Acres)	Spillway Capacity <sup>5</sup>		Freeboard <sup>6</sup>
					Principal <sup>2</sup>	Emergency <sup>3,4</sup>	
“c” & “b”	Any	Any	Any	Any	TR 60	TR 60	TR 60
“a”	3,000 or more	Any	Any	Any	TR 60	TR 60	TR 60
“a”	Less	320 and Larger	>20 - 35	≥12	TR 60	50 YR	2.0’ above E.S. Design Storm
			≤20	≥12	25 YR	50 YR	
			<15	<12	10 YR	50 YR	
	than	100 to 320	>20 - 35	≥12	TR 60	50 YR	2.0’ above E.S. Design Storm
			≤20	≥12	10 YR	50 YR	1.0’ above E.S. Design Storm
			<15	<12	2 YR	50 YR	1.0’ above E.S. Design Storm
	3,000	Less Than 100	>20 - 35	≥12	TR 60	50 YR	1.0’ above E.S. Design Storm
			≤20	≥12	2 YR	50 YR	
			<15	<12	2 YR	50 YR	

NOTES:

- 1) The storage is defined as the original capacity of the reservoir in acre-feet at the elevation of the crest of the emergency spillway. The effective height is the difference in elevation in feet between the emergency spillway crest and the lowest point on a profile taken along the centerline of the dam, excluding the cutoff trench. If there is no emergency spillway, this height shall be to the top of the dam.
- 2) Principal - minimum storm to be contained below the crest of the emergency spillway including any combination of temporary storage and principal spillway discharge.
- 3) Emergency - minimum storm used to proportion the emergency spillway to meet the limitations for shape, size, velocity and exit channel. This storm can be handled by any combination of principal spillway discharge, emergency spillway discharge and storage.
- 4) For ponds without a separate emergency spillway, the principal spillway functions as the emergency spillway. In this situation, the principal spillway must comply with the emergency spillway hydrologic criteria.
- 5) All ponds, which are being designed to meet local stormwater requirements, will be required to use the urban criteria. Storm duration used shall be 24 hours except where TR-60 is specified.
- 6) For ponds without a functioning open channel emergency spillway, minimum freeboard will be 2 feet.

**Table 6.2 Minimum Top Width of Embankments**

Total Height Of Embankment (Feet)	Minimum Top Width (Feet)
10 or less	6
11 - 14	8
15 - 19	10
20 - 24	12
25 - 34	14
35 or more	15

**Table 6.3<sup>1,2</sup> Minimum Gages-Steel Pipe**

*CORRUGATED STEEL PIPE  
2 - 2/3 inches x 1/2 inch Corrugations*

Fill Height Over Pipe (Feet)	Pipe Diameter in Inches				
	24 & Less	30	36	42	48
1 - 15	16	16	14	10	10
15 - 20	16	12	10	*	*
20 - 25	16	10	*	*	*

*CORRUGATED STEEL PIPE  
3 inches x 1 inch or 5 inch x 1 inch Corrugations*

Fill Height Over Pipe (Feet)	Pipe Diameter (Inches)						
	Flowable Fill						
	36	42	48	54 <sup>s</sup>	60 <sup>s</sup>	66 <sup>s</sup>	72 <sup>s</sup>
1 - 15	16	16	16	14	14	14	14
15 - 20	16	16	12	14	14	14	14
20 - 25	14	14	10	14	14	14	14

- Not Permitted.

**Table 6.4<sup>1,2</sup> Minimum Gages-Aluminum Pipe**

*CORRUGATED ALUMINUM PIPE  
2 - 2/3 inches x 1/2 inch Corrugations*

Fill Height Over Pipe (Feet)	Pipe Diameter in Inches		
	21 & Less	24	30
1 - 15	16	14	10
15 - 20	12	10	*
20 - 25	10	*	*



**CORRUGATED ALUMINUM PIPE**  
*3 inches x 1 inch Corrugations*

Fill Height Over Pipe (Feet)	Pipe Diameter in Inches				
	30	36	42	48	54 <sup>3</sup>
1 - 15	16	16	14	10	14
15 - 20	16	12	*	*	*
20 - 25	12	*	*	*	*

\* Not Permitted.

<sup>1</sup> Coatings for corrugated metal shall be as specified by the MD-378 Construction Specifications.

<sup>2</sup> Tables 3 and 4 were developed using the modified Spangler equation. Sizes other than those shown above are not permitted.

<sup>3</sup> Must use flowable backfill as specified by the MD-378 Construction Specifications and the pipe must be bituminous coated.

**Table 6.5 Acceptable Plastic Pipe For Use In Earth Dam<sup>1,2</sup>**

Nominal Pipe Size (inches)	Schedule or Standard Dimension Ratio (SDR)	Maximum Depth of Fill Over <sup>3</sup>
6 - 24	PVC Schedule 40	10
6 - 24	PVC Schedule 80	15
6 - 24	PVC SDR 26	10
6 - 24	Corrugated HDPE	10

<sup>1</sup> See Specifications, Plastic Pipe

<sup>2</sup> All designs based on Technical Release 77, Reference 20. Other diameters and / or fill heights may be used that meet all the requirements of TR-77.

<sup>3</sup> larger fill heights may be permitted when using flowable fill.

**<This page left blank intentionally>**

## 6.2 Construction Standards/Specifications for Ponds and Wetlands

These specifications are generally appropriate to all earthen ponds. Practitioners should consult applicable dam safety regulations for the latest version of pond construction specifications. All references to ASTM and AASHTO specifications apply to the most recent version.

### **Site Preparation**

Areas designated for borrow areas, embankment, and structural works shall be cleared, grubbed and stripped of topsoil. All trees, vegetation, roots and other objectionable material shall be removed. Channel banks and sharp breaks shall be sloped to no steeper than 1:1. All trees shall be cleared and grubbed within 15 feet of the toe of the embankment.

Areas to be covered by the impoundment will be cleared of all trees, brush, logs, fences, rubbish and other objectionable material unless otherwise designated on the plans. Trees, brush, and stumps shall be cut approximately level with the ground surface. For dry stormwater management detention ponds, a minimum of a 25-foot radius around the inlet structure shall be cleared.

All cleared and grubbed material shall be disposed of outside and below the limits of the dam and reservoir as directed by the owner or his representative. When specified, a sufficient quantity of topsoil will be stockpiled in a suitable location for use on the embankment and other designated areas.

### **Earth Fill**

**Material** - The fill material shall be taken from approved designated borrow areas. It shall be free of roots, stumps, wood, rubbish, stones greater than 6", frozen or other objectionable materials. Fill material for the center of the embankment, and cut off trench shall conform to Unified Soil Classification GC, SC, CH, or CL and must have at least 30% passing the #200 sieve. Consideration may be given to the use of other materials in the embankment if designed by a geotechnical engineer. Such special designs must have construction supervised by a geotechnical engineer.

Materials used in the outer shell of the embankment must have the capability to support vegetation of the quality required to prevent erosion of the embankment.

**Placement** - Areas on which fill is to be placed shall be scarified prior to placement of fill. Fill materials shall be placed in maximum 8-inch thick (before compaction) layers which are to be continuous over the entire length of the fill. The most permeable borrow material shall be placed in the downstream portions of the embankment. The principal spillway must be installed concurrently with fill placement and not excavated into the embankment.

**Compaction** - The movement of the hauling and spreading equipment over the fill shall be controlled so that the entire surface of each lift shall be traversed by not less than one tread track of heavy equipment or compaction shall be achieved by a minimum of four complete passes of a sheepsfoot, rubber tired or vibratory roller. Fill material shall contain sufficient moisture such that the required degree of compaction will be obtained with the equipment used. The fill

material shall contain sufficient moisture so that if formed into a ball it will not crumble, yet not be so wet that water can be squeezed out.

When required by the reviewing agency the minimum required density shall not be less than 95% of maximum dry density with a moisture content within 2% of the optimum. Each layer of fill shall be compacted as necessary to obtain that density, and is to be certified by the Engineer at the time of construction. All compaction is to be determined by AASHTO Method T-99 (Standard Proctor).

***Cut-off Trench*** - The cut-off trench shall be excavated into impervious material along or parallel to the centerline of the embankment as shown on the plans. The bottom width of the trench shall be governed by the equipment used for excavation, with the minimum width being four feet. The depth shall be at least four feet below existing grade or as shown on the plans. The side slopes of the trench shall be 1:1 or flatter. The backfill shall be compacted with construction equipment, rollers, or hand tampers to assure maximum density and minimum permeability.

***Embankment Core*** - The core shall be parallel to the centerline of the embankment as shown on the plans. The top width of the core shall be a minimum of four feet. The height shall extend up to at least the 25-year water elevation or as shown on the plans. The side slopes shall be 1:1 or flatter. The core shall be compacted with construction equipment, rollers, or hand tampers to assure maximum density and minimum permeability. In addition, the core shall be placed concurrently with the outer shell of the embankment.

### **Structure Backfill**

Backfill adjacent to pipes or structures shall be of the type and quality conforming to that specified for the adjoining fill material. The fill shall be placed in horizontal layers not to exceed four inches in thickness and compacted by hand tampers or other manually directed compaction equipment. The material needs to fill completely all spaces under and adjacent to the pipe. At no time during the backfilling operation shall driven equipment be allowed to operate closer than four feet, measured horizontally, to any part of a structure. Under no circumstances shall equipment be driven over any part of a concrete structure or pipe, unless there is a compacted fill of 24 inches or greater over the structure or pipe.

Structure backfill may be flowable fill meeting the requirements of the Federal Highway Administration standards. The mixture shall have a 100-200 psi; 28-day unconfined compressive strength. The flowable fill shall have a minimum pH of 4.0 and a minimum resistivity of 2,000 ohm-cm. Material shall be placed such that a minimum of 6 inches (measured perpendicular to the outside of the pipe) of flowable fill shall be under (bedding), over and, on the sides of the pipe. It only needs to extend up to the spring line for rigid conduits. Average slump of the fill shall be 7 inches to assure flowability of the material. Adequate measures shall be taken (sand bags, etc.) to prevent floating the pipe. When using flowable fill, all metal pipe shall be bituminous coated. Any adjoining soil fill shall be placed in horizontal layers not to exceed 4 inches in thickness and compacted by hand tampers or other manually directed compaction equipment. The material shall completely fill all voids adjacent to the flowable fill zone. At no time during the backfilling operation shall driven equipment be allowed to operate closer than four feet, measured horizontally, to any part of a structure. Under no circumstances shall equipment be driven over any part of a structure or pipe unless there is a

compacted fill of 24 inches or greater over the structure or pipe. Backfill material outside the structural backfill (flowable fill) zone shall be of the type and quality conforming to that specified for the core of the embankment or other embankment materials.

### **Pipe Conduits**

All pipes shall be circular in cross section.

**Corrugated Metal Pipe** - All of the following criteria shall apply for corrugated metal pipe:

- **Materials - (Polymer-coated steel pipe)** - Steel pipes with polymeric coatings shall have a minimum coating thickness of 0.01 inch (10 mil) on both sides of the pipe. This pipe and its appurtenances shall conform to the requirements of AASHTO Specifications M-245 & M-246 with watertight coupling bands or flanges.
- **Materials - (Aluminum-coated Steel Pipe)** - This pipe and its appurtenances shall conform to the requirements of AASHTO Specification M-274 with watertight coupling bands or flanges. Aluminum Coated Steel Pipe, when used with flowable fill or when soil and/or water conditions warrant the need for increased durability, shall be fully bituminous coated per requirements of AASHTO Specification M-190 Type A. Any aluminum coating damaged or otherwise removed shall be replaced with cold applied bituminous coating compound. Aluminum surfaces that are to be in contact with concrete shall be painted with one coat of zinc chromate primer or two coats of asphalt.
- **Materials - (Aluminum Pipe)** - This pipe and its appurtenances shall conform to the requirements of AASHTO Specification M-196 or M-211 with watertight coupling bands or flanges. Aluminum Pipe, when used with flowable fill or when soil and/or water conditions warrant for increased durability, shall be fully bituminous coated per requirements of AASHTO Specification M-190 Type A. Aluminum surfaces that are to be in contact with concrete shall be painted with one coat of zinc chromate primer or two coats of asphalt. Hot dip galvanized bolts may be used for connections. The pH of the surrounding soils shall be between 4 and 9.
- **Coupling bands, anti-seep collars, end sections, etc.,** must be composed of the same material and coatings as the pipe. Metals must be insulated from dissimilar materials with use of rubber or plastic insulating materials at least 24 mils in thickness.
- **Connections** - All connections with pipes must be completely watertight. The drain pipe or barrel connection to the riser shall be welded all around when the pipe and riser are metal. Anti-seep collars shall be connected to the pipe in such a manner as to be completely watertight. Dimple bands are not considered to be watertight.

All connections shall use a rubber or neoprene gasket when joining pipe sections. The end of each pipe shall be re-rolled an adequate number of corrugations to accommodate the bandwidth. The following type connections are acceptable for pipes less than 24 inches in diameter: flanges on both ends of the pipe with a circular 3/8 inch closed cell neoprene gasket, pre-punched to the flange bolt circle, sandwiched between adjacent flanges; a 12-inch wide standard lap type band with 12-inch wide by 3/8-inch thick

closed cell circular neoprene gasket; and a 12-inch wide hugger type band with o-ring gaskets having a minimum diameter of 1/2 inch greater than the corrugation depth. Pipes 24 inches in diameter and larger shall be connected by a 24-inch long annular corrugated band using a minimum of 4 (four) rods and lugs, 2 on each connecting pipe end. A 24-inch wide by 3/8-inch thick closed cell circular neoprene gasket will be installed with 12 inches on the end of each pipe. Flanged joints with 3/8-inch closed cell gaskets the full width of the flange is also acceptable.

Helically corrugated pipe shall have either continuously welded seams or have lock seams with internal caulking or a neoprene bead.

- Bedding - The pipe shall be firmly and uniformly bedded throughout its entire length. Where rock or soft, spongy or other unstable soil is encountered, all such material shall be removed and replaced with suitable earth compacted to provide adequate support.
- Backfilling shall conform to "**Structure Backfill**".
- Other details (anti-seep collars, valves, etc.) shall be as shown on the drawings.

**Reinforced Concrete Pipe** - All of the following criteria shall apply for reinforced concrete pipe:

- Materials - Reinforced concrete pipe shall have bell and spigot joints with rubber gaskets and shall equal or exceed ASTM C-361.
- Bedding - Reinforced concrete pipe conduits shall be laid in a concrete bedding / cradle for their entire length. This bedding / cradle shall consist of high slump concrete placed under the pipe and up the sides of the pipe at least 50% of its outside diameter with a minimum thickness of 6 inches. Where a concrete cradle is not needed for structural reasons, flowable fill may be used as described in the "**Structure Backfill**" section of this standard. Gravel bedding is not permitted.
- Laying pipe - Bell and spigot pipe shall be placed with the bell end upstream. Joints shall be made in accordance with recommendations of the manufacturer of the material. After the joints are sealed for the entire line, the bedding shall be placed so that all spaces under the pipe are filled. Care shall be exercised to prevent any deviation from the original line and grade of the pipe. The first joint must be located within 4 feet from the riser.
- Backfilling shall conform to "**Structure Backfill**".
- Other details (anti-seep collars, valves, etc.) shall be as shown on the drawings.

**Plastic Pipe** - The following criteria shall apply for plastic pipe:

- Materials - PVC pipe shall be PVC-1120 or PVC-1220 conforming to ASTM D-1785 or ASTM D-2241. Corrugated High Density Polyethylene (HDPE) pipe, couplings and fittings shall conform to the following: 4 – 10 inch pipe shall meet the requirements of AASHTO M252 Type S, and 12 inch through 24 inch shall meet the requirements of AASHTO M294 Type S.
- Joints and connections to anti-seep collars shall be completely watertight.

- Bedding -The pipe shall be firmly and uniformly bedded throughout its entire length. Where rock or soft, spongy or other unstable soil is encountered, all such material shall be removed and replaced with suitable earth compacted to provide adequate support.
- Backfilling shall conform to “**Structure Backfill**.”
- Other details (anti-seep collars, valves, etc.) shall be as shown on the drawings.

**Drainage Diaphragms** - When a drainage diaphragm is used, a registered professional engineer will supervise the design and construction inspection.

### **Concrete**

Concrete shall meet the requirements of the Federal Highway Administration Standard Specifications for Construction and Materials.

### **Rock Riprap**

Rock riprap shall meet the requirements of the Federal Highway Administration.

Geotextile shall be placed under all riprap and shall meet the requirements of the Federal Highway Administration.

### **Care of Water during Construction**

All work on permanent structures shall be carried out in areas free from water. The Contractor shall construct and maintain all temporary dikes, levees, cofferdams, drainage channels, and stream diversions necessary to protect the areas to be occupied by the permanent works. The contractor shall also furnish, install, operate, and maintain all necessary pumping and other equipment required for removal of water from various parts of the work and for maintaining the excavations, foundation, and other parts of the work free from water as required or directed by the engineer for constructing each part of the work. After having served their purpose, all temporary protective works shall be removed or leveled and graded to the extent required to prevent obstruction in any degree whatsoever of the flow of water to the spillway or outlet works and so as not to interfere in any way with the operation or maintenance of the structure. Stream diversions shall be maintained until the full flow can be passed through the permanent works. The removal of water from the required excavation and the foundation shall be accomplished in a manner and to the extent that will maintain stability of the excavated slopes and bottom required excavations and will allow satisfactory performance of all construction operations. During the placing and compacting of material in required excavations, the water level at the locations being refilled shall be maintained below the bottom of the excavation at such locations which may require draining the water sumps from which the water shall be pumped.

### **Stabilization**

All borrow areas shall be graded to provide proper drainage and left in a slightly condition. All exposed surfaces of the embankment, spillway, spoil and borrow areas, and berms shall be stabilized by seeding, liming, fertilizing and mulching in accordance with local Natural Resources Conservation Service Standards and Specifications.

## **Erosion and Sediment Control**

Construction operations will be carried out in such a manner that erosion will be controlled and water and air pollution minimized. Commonwealth or Territory laws concerning pollution abatement will be followed. Construction plans shall detail erosion and sediment control measures.

## **OPERATION AND MAINTENANCE**

An operation and maintenance plan in accordance with Commonwealth or Territory Regulations will be prepared for all ponds. As a minimum, a dam inspection checklist shall be included as part of the operation and maintenance plan and performed at least annually. Written records of maintenance and major repairs need to be retained in a file.

## **Supplemental Stormwater Pond and Wetland Specifications**

1. It is preferred to use the same material in the embankment as is being installed for the core trench. If this is not possible because the appropriate material is not available, a dam core with a shell may be used. The cross-section of the stormwater facility should show the limits of the dam core (up to the 25-year water surface elevation) as well as the acceptable materials for the shell. The shape of the dam core and the material to be used in the shell should be provided by the design engineer.
2. If the compaction tests for the remainder of the site improvements are using Modified Proctor (AASHTO T-180), then to maintain consistency on-site, modified proctor may be used in lieu of standard proctor (AASHTO T-99). The minimum required density using the modified proctor test method shall be at least 92% of maximum dry density with a moisture content of  $\pm 2\%$  of the optimum.
3. For all stormwater management facilities, a licensed professional engineer (civil) must be present to verify compaction in accordance with the selected test method. This information needs to be provided in a report to the design engineer, so that certification of the construction of the facility can be made.
4. A 4-inch layer of topsoil shall be placed on all disturbed areas of the dam embankment. Seeding, liming, fertilizing, mulching, etc. shall be in accordance with NRCS Soil Standards and Specifications. The purpose of the topsoil is to establish a good growth of grass which is not always possible with some of the materials that may be placed for the embankment fill.
5. Filter fabric placed beneath the rip-rap shall meet federal department of transportation requirements for a Class "C" filter fabric. Some acceptable filter fabrics that meet the Class "C" criteria include:
  - Mirafi 180-N
  - Amoco 4552
  - Webtec N07
  - Geolon N70
  - Carthage FX-70S



This is only a partial listing of available filter fabrics based on information provided by the manufacturers to the 1997 Specifier's Guide dated December 1996. It is the responsibility of the engineer to verify the adequacy of the material, as there are changes in the manufacturing process and the type of fabric used, which may affect the continued acceptance.

6. The design engineer and geotechnical engineer should make the determination that the settlement of the pond will not cause excessive joint extension. For further information on joint extension analysis, see NRCS Publication TR-18.

7. Fill placement shall not exceed a maximum of 8 inches. Each lift shall be continuous for the entire length of the embankment.

8. The embankment fill **shall not** be placed higher than the centerline of the principle spillway until after the principle spillway has been installed. If the embankment needs to be excavated to install the principle spillway, the side slope shall be no less than 2:1.

9. The side slopes of a cut to repair a dam, install a principle spillway for an excavated pond, or other repair work, shall be done on a slope of no less than 2:1.

**<This page left blank intentionally>**

**Table 6.6 Stormwater Pond/Wetland Construction Inspection Checklist**

**Project:**

**Location:**

**Site Status:**

**Date:**

**Time:**

**Inspector:**

CONSTRUCTION SEQUENCE	SATISFACTORY/ UNSATISFACTORY	COMMENTS
<b>1. Pre-Construction/Materials and Equipment</b>		
Pre-construction meeting		
Pipe and appurtenances on-site prior to construction and dimensions checked		
1. Material (including protective coating, if specified)		
2. Diameter		
3. Dimensions of metal riser or pre-cast concrete outlet structure		
4. Required dimensions between water control structures (orifices, weirs, etc.) are in accordance with approved plans		
5. Barrel stub for prefabricated pipe structures at proper angle for design barrel slope		
6. Number and dimensions of prefabricated anti-seep collars		
7. Watertight connectors and gaskets		
8. Outlet drain valve		
Project benchmark near pond site		

CONSTRUCTION SEQUENCE	SATISFACTORY/ UNSATISFACTORY	COMMENTS
Equipment for temporary de-watering		
<b>2. Subgrade Preparation</b>		
Area beneath embankment stripped of all vegetation, topsoil, and organic matter		
<b>3. Pipe Installation</b>		
Method of installation detailed on plans		
A. Bed preparation		
Installation trench excavated with specified side slopes		
Stable, uniform, dry subgrade of relatively impervious material (If subgrade is wet, contractor shall have defined steps before proceeding with installation)		
Invert at proper elevation and grade		
B. Pipe placement		
Metal/plastic pipe		
1. Watertight connectors and gaskets properly installed		
2. Anti-seep collars properly spaced and having watertight connections to pipe		
3. Backfill placed and tamped by hand under “haunches” of pipe		
4. Remaining backfill placed in max. 8 inch lifts using small power tamping equipment until 2 ft cover over pipe is reached		
Concrete pipe		
1. Pipe set on blocks or concrete slab for pouring of low cradle		

CONSTRUCTION SEQUENCE	SATISFACTORY/ UNSATISFACTORY	COMMENTS
2. Pipe installed with rubber gasket joints with no spalling in gasket interface area		
3. Excavation for lower half of anti-seep collar(s) with reinforcing steel set		
4. Entire area where anti-seep collar(s) will come in contact with pipe coated with mastic or other approved waterproof sealant		
5. Low cradle and bottom half of anti-seep collar installed as monolithic pour and of an approved mix		
6. Upper half of anti-seep collar(s) formed with reinforcing steel set		
7. Concrete for collar of an approved mix and vibrated into place		
8. Forms stripped and collar inspected for honeycomb prior to backfilling. Parge if necessary.		
<b>C. Backfilling</b>		
Fill placed in maximum 8-in lifts		
Backfill taken minimum 2 ft above top of anti-seep collar elevation before traversing with heavy equipment		
<b>4. Riser / Outlet Structure Installation</b>		
Riser located within embankment		
<b>A. Metal riser</b>		
Riser base excavated or formed on stable subgrade to design dimensions		
Set on blocks to design elevations and plumbed		

CONSTRUCTION SEQUENCE	SATISFACTORY/ UNSATISFACTORY	COMMENTS
Reinforcing bars placed at right angles and projecting into sides of riser		
Concrete poured so as to fill inside of riser to invert of barrel		
<b>B. Pre-cast concrete structure</b>		
Dry and stable subgrade		
Riser base set to design elevation		
If more than one section, no spalling in gasket interface area; gasket or approved caulking material placed securely		
Watertight and structurally sound collar or gasket joint where structure connects to pipe spillway		
<b>C. Poured concrete structure</b>		
Footing excavated or formed on stable subgrade, to design dimensions with reinforcing steel set		
Structure formed to design dimensions, with reinforcing steel set as per plan		
Concrete of an approved mix and vibrated into place		
Forms stripped & inspected for “honeycomb” prior to backfilling; parge if necessary		
<b>5. Embankment Construction</b>		
Fill material		
Compaction		
<b>Embankment</b>		
1. Fill placed in specified lifts and compacted with appropriate equipment		

CONSTRUCTION SEQUENCE	SATISFACTORY/ UNSATISFACTORY	COMMENTS
2. Constructed to design cross-section, side slopes and top width		
3. Constructed to design elevation plus allowance for settlement		
<b>6. Impounded Area Construction</b>		
Excavated / graded to design contours and side slopes		
Inlet pipes have adequate outfall protection		
Forebay(s)		
Pond benches		
<b>7. Earth Emergency Spillway Construction</b>		
Spillway located in cut or structurally stabilized with riprap, gabions, concrete, etc.		
Excavated to proper cross-section, side slopes and bottom width		
Entrance channel, crest, and exit channel constructed to design grades and elevations		
<b>8. Outlet Protection</b>		
A. End section		
Securely in place and properly backfilled		
B. Endwall		
Footing excavated or formed on stable subgrade, to design dimensions and reinforcing steel set, if specified		
Endwall formed to design dimensions with reinforcing steel set as per plan		
Concrete of an approved mix and vibrated into place		

CONSTRUCTION SEQUENCE	SATISFACTORY/ UNSATISFACTORY	COMMENTS
Forms stripped and structure inspected for “honeycomb” prior to backfilling; pare if necessary		
<b>C. Riprap apron / channel</b>		
Apron / channel excavated to design cross-section with proper transition to existing ground		
Filter fabric in place		
Stone sized as per plan and uniformly placed at the thickness specified		
<b>9. Vegetative Stabilization</b>		
Approved seed mixture		
Proper surface preparation and required soil amendments		
Excelsior mat or other stabilization, as per plan		
<b>10. Miscellaneous</b>		
Drain for ponds having a permanent pool		
Trash rack / anti-vortex device secured to outlet structure		
Trash protection for low flow pipes, orifices, etc.		
Fencing (when required)		
Access road		
Set aside for clean-out maintenance		
<b>11. Stormwater Wetlands</b>		
Adequate water balance		
Variety of depth zones present		
Approved pondscaping plan in place and budget for additional plantings		



CONSTRUCTION SEQUENCE	SATISFACTORY/ UNSATISFACTORY	COMMENTS
Plants and materials ordered 6 months prior to construction		
Construction planned to allow for adequate planting and establishment of plant community		
Wetland buffer area preserved to maximum extent possible		

**Comments:**

---



---



---



---



---



---

**Actions to be Taken:**

---



---



---



---



---



---

**<This page left blank intentionally>**

## 6.3 Construction Standards/Specifications for Infiltration BMPs

### Infiltration Trench/Chamber General Notes and Specifications

Infiltration trench or chamber systems may not receive run-off until the entire contributing drainage area to the infiltration system has received final stabilization.

1. Heavy equipment and traffic shall be restricted from traveling over the infiltration trench or chamber to minimize compaction of the soil.
2. Excavate the infiltration trench/chamber to the design dimensions. Excavated materials shall be placed away from the trench/chamber sides to enhance trench wall stability. Large tree roots must be trimmed flush with the trench sides in order to prevent fabric puncturing or tearing of the filter fabric during subsequent installation procedures. The side walls of the trench/chamber shall be roughened where sheared and sealed by heavy equipment.
3. A Class “C” geotextile or better shall interface between the trench/chamber side walls and between the stone reservoir and gravel filter layers. A partial list of non-woven filter fabrics that meet the Class “C” criteria is contained below. Any alternative filter fabric must be approved by the Commonwealth (Territory).

Mirafi 180-N  
Amoco 4552  
WEBTEC N70  
GEOLON N70  
Carthage FX-80S

The width of the geotextile must include sufficient material to conform to trench/chamber perimeter irregularities and for a 6-inch minimum top overlap. The filter fabric shall be tucked under the sand layer on the bottom of the infiltration trench/chamber for a distance of 6 to 12 inches. Stones or other anchoring objects should be placed on the fabric at the edge of the trench/chamber to keep the trench open during windy periods. When overlaps are required between rolls, the uphill roll should lap a minimum of 2 feet over the downhill roll in order to provide a shingled effect.

4. A 6-inch sand filter layer may be placed on the bottom of the infiltration trench/chamber in lieu of filter fabric, and shall be compacted using plate compactors. The sand for the infiltration trench shall be washed and meet AASHTO Std. M-43, Size No. 9 or No. 10. Any alternative sand gradation must be approved by the Engineer or the Commonwealth (Territory).
5. The stone aggregate should be placed in lifts and compacted using plate compactors. A maximum loose lift thickness of 12 inches is recommended. The gravel (washed, rounded limestone aggregate is preferred) for the infiltration trench/chamber shall be washed and meet one of the following AASHTO Std. M-43; Size No. 2 or No. 3.

6. Infiltration chambers should consist of high molecular weight high density polyethylene (HDPE) and meet AASHTO H10 and H20 standards. Chambers should have repeating endwalls for internal support. Infiltration chambers must be constructed in accordance with manufacturer's specifications. All chambers must be approved by the Commonwealth (Territory).
7. Following the stone aggregate placement, the filter fabric shall be folded over the stone aggregate to form a 6-in minimum longitudinal lap. The desired fill soil or stone aggregate shall be placed over the lap at sufficient intervals to maintain the lap during subsequent backfilling.
8. Care shall be exercised to prevent natural or fill soils from intermixing with the stone aggregate. All contaminated stone aggregate shall be removed and replaced with uncontaminated stone aggregate.
9. Voids can be created between the fabric and the excavation sides and shall be avoided. Removing boulders or other obstacles from the trench walls is one source of such voids; therefore, natural soils should be placed in these voids at the most convenient time during construction to ensure fabric conformity to the excavation sides.
10. Vertically excavated walls may be difficult to maintain in areas where soil moisture is high or where soft cohesive or cohesionless soils are predominate. These conditions may require laying back of the side slopes to maintain stability.
11. PVC distribution pipes shall be Schedule 40 and meet ASTM Std. D 1784. All fittings and perforations (1/2 inch in diameter) shall meet ASTM Std. D 2729. A perforated pipe shall be provided only within the infiltration trench/chamber and shall terminate 1 ft short of the infiltration trench wall. The end of the PVC pipe shall be capped.
12. The corrugated metal distribution pipes shall conform to AASHTO Std. M-36 and shall be aluminized in accordance with AASHTO Std. M-274. Coat aluminized pipe in contact with concrete with an inert compound capable of effecting isolation of the deleterious effect of the aluminum on the concrete. Perforated distribution pipe shall be provided only within the infiltration trench/chamber and shall terminate 1 ft short of the infiltration trench wall. An aluminized metal plate shall be welded to the end of the pipe.
13. Corrugated High Density Polyethylene (HDPE) pipe, couplings and fittings shall conform to the following: 4-10-in pipe shall meet the requirements of AASHTO M252 Type S, and 12in through 24in shall meet the requirements of AASHTO M294 Type S. Perforated distribution pipe shall be provided only within the infiltration trench/chamber and shall terminate 1 ft short of the infiltration trench wall. The end of the pipe shall be capped.
14. The observation well is to consist of 4 to 6-inch diameter PVC Schedule 40 pipe (ASTM Std. D 1784) with a cap set 6 inches above ground level and is to be located near the

longitudinal center of the infiltration trench or chamber. Preferably the observation well will not be located in vehicular traffic areas. The pipe shall have a plastic collar with ribs to prevent rotation when removing cap. The screw top lid shall be a “Panella” type cleanout with a locking mechanism or special bolt to discourage vandalism.

15. If a distribution structure with a wet well is used, a 4-inch PVC drain pipe shall be provided at opposite ends of the infiltration trench/chamber distribution structure. Two (2) cubic feet of porous backfill meeting AASHTO Std. M-43 Size No. 57 shall be provided at each drain.
16. If a distribution structure is used, the manhole cover shall be bolted to the frame.

NOTE: PVC pipe with a wall thickness classification of SDR-35 meeting ASTM standard D3034 is an acceptable substitution for PVC Schedule 40 pipe.

**<This page left blank intentionally>**

**Table 6.7 Infiltration Trench/Chamber Construction Inspection Checklist**

**Project:**

**Location:**

**Site Status:**

**Date:**

**Time:**

**Inspector:**

CONSTRUCTION SEQUENCE	SATISFACTORY/ UNSATISFACTORY	COMMENTS
<b>1. Pre-Construction</b>		
Pre-construction meeting		
Runoff diverted		
Soil permeability tested		
Groundwater / bedrock sufficient at depth		
<b>2. Excavation</b>		
Size and location		
Side slopes stable		
Excavation does not compact subsoils		
<b>3. Filter Fabric Placement</b>		
Fabric specifications		
Placed on bottom, sides, and top		
<b>4. Aggregate Material</b>		
Size as specified		
Clean / washed material		

CONSTRUCTION SEQUENCE	SATISFACTORY/ UNSATISFACTORY	COMMENTS
Placed properly		
<b>5. Observation Well</b>		
Pipe size		
Removable cap / footplate		
Initial depth = _____ feet		
<b>6. Final Inspection</b>		
Pretreatment facility in place		
Contributing watershed stabilized prior to flow diversion		
Outlet		

**Comments:**

---



---



---



---



---



---



---

**Actions to be Taken:**

---



---



---



---



---



---



---



---



---



---



---



## Infiltration Basins Notes and Specifications

1. The sequence of various phases of basin construction shall be coordinated with the overall project construction schedule. A program should schedule rough excavation of the basin with the rough grading phase of the project to permit use of the material as fill in earthwork areas. The partially excavated basin, however, cannot serve as a sedimentation basin.

Specifications for basin construction should state: (1) the earliest point in progress when storm drainage may be directed to the basin, and (2) the means by which this delay in use is to be accomplished. Due to the wide variety of conditions encountered among projects, each should be separately evaluated in order to postpone use as long as is reasonably possible.

2. Initial basin excavation should be carried to within 1 foot of the final elevation of the basin floor. Final excavation to the finished grade should be deferred until all disturbed areas on the watershed have been stabilized or protected. The final phase excavation should remove all accumulated sediment. Relatively light-tracked equipment is recommended for this operation to avoid compaction of the basin floor. After the final grading is completed, the basin provides a well-aerated, highly porous surface texture.
3. Infiltration basins may be lined with a 6- to 12-inch layer of filter material such as coarse sand (AASHTO Std. M-43, Sizes 9 or 10) to help prevent the buildup of impervious deposits on the soil surface. The filter layer can be replaced or cleaned when it becomes clogged. When a 6-inch layer of coarse organic material is specified for discing (such as hulls, leaves, stems, etc.) or spading into the basin floor to increase the permeability of the soils, the basin floor should be soaked or inundated for a brief period, then allowed to dry subsequent to this operation. This induces the organic material to decay rapidly, loosening the upper soil layer.
4. Establishing dense vegetation on the basin side slopes and floor is recommended. A dense vegetative stand will not only prevent erosion and sloughing, but will also provide a natural means of maintaining relatively high infiltration rates. Erosion protection of inflow points to the basin shall also be provided.
5. Selection of suitable vegetative materials for the side slope and all other areas to be stabilized with vegetation and application of required lime, fertilizer, etc. shall be done in accordance with the NRCS Standards and Specifications.
6. Grasses of the fescue family are recommended for seeding primarily due to their adaptability to dry sandy soils, drought resistance, hardiness, and ability to withstand brief inundations. The use of fescues will also permit long intervals between mowings. This is important due to the relatively steep slopes that make mowing difficult. Mowing 4 times a year, once in March, June, September, and December, is generally satisfactory. Re-fertilization with 10-6-4 ratio fertilizer at a rate of 500 lb per acre (11 lb per 1000 sq ft) may be required the second year after seeding.

**<This page left blank intentionally>**

**Table 6.8 Infiltration Basin Construction Inspection Checklist**

**Project:**

**Location:**

**Site Status:**

**Date:**

**Time:**

**Inspector:**

CONSTRUCTION SEQUENCE	SATISFACTORY/ UNSATISFACTORY	COMMENTS
<b>1. Pre-Construction</b>		
Runoff diverted		
Soil permeability tested		
Groundwater / bedrock depth		
<b>2. Excavation</b>		
Size and location		
Side slopes stable		
Excavation does not compact subsoils		
<b>3. Embankment</b>		
Barrel		
Anti-seep collar or Filter diaphragm		
Fill material		
<b>4. Final Excavation</b>		
Drainage area stabilized		
Sediment removed from facility		
Basin floor tilled		

CONSTRUCTION SEQUENCE	SATISFACTORY/ UNSATISFACTORY	COMMENTS
Facility stabilized		
<b>5. Final Inspection</b>		
Pretreatment facility in place		
Inlets / outlets		
Contributing watershed stabilized before flow is routed to the facility		

**Comments:**

---



---



---



---



---



---

**Actions to be Taken:**

---



---



---



---



---



---

## 6.4 Construction Standards/Specifications for Filter BMPs

### Sand Filter Specifications

#### *Material Specifications for Sand Filters*

The allowable materials for sand filter construction are detailed in **Table 6.4**.

#### *Sand Filter Testing Specifications*

Underground sand filter applications, facilities within sensitive groundwater aquifers, and filters designed to serve urban hotspots are to be tested for watertightness prior to placement of filter layers. The systems should be tested for watertightness using the US EPA test procedures as described below and included in the Onsite Wastewater Treatment Systems Manual (USEPA, 2002). Hydrostatic or vacuum tests, and manway risers and inspection ports should be included in the test. The professional association representing the materials industry of the type of tank construction (e.g., the National Pre-cast Concrete Association) should be contacted to establish the appropriate testing criteria and procedures. Test criteria for precast concrete are presented below in **Table 6.9**.

**Table 6.9 Watertightness Testing Procedure/Criteria for Precast Concrete Tanks (USEPA, 2002)**

Standard	Hydrostatic test		Vacuum test	
	Preparation	Pass/fail criterion	Preparation	Pass/fail criterion
<b>C 1227, ASTM (1993)</b>	Seal tank, fill with water, and let stand for 24 hours. Refill tank.	Approved if water level is held for 1 hour	Seal tank and apply a vacuum of 2 in. Hg.	Approved if 90% of vacuum is held for 2 minutes.
<b>NPCA (1998)</b>	Seal tank, fill with water, and let stand for 8 to 10 hours. Refill tank and let stand for another 8 to 10 hours.	Approved if no further measurable water level drop occurs	Seal tank and apply a vacuum of 4 in. Hg. Hold vacuum for 5 minutes. Bring vacuum back to 4 in. Hg.	Approved if vacuum can be held for 5 minutes without a loss of vacuum.

All overflow weirs, multiple orifices and flow distribution slots to be field-tested as to verify adequate distribution of flows.

#### *Sand Filter Construction Specifications*

Provide sufficient maintenance access; 12-ft-wide road with legally recorded easement. Vegetated access slopes to be a maximum of 10%; gravel slopes to 15%; paved slopes to 25%.

*Absolutely no runoff* is to enter the filter until all contributing drainage areas have been stabilized.

Surface of filter bed to be *completely level*.

All sand filters should be clearly delineated with signs so that they may be located when maintenance is due.

Surface sand filter applications shall be planted with appropriate grasses as specified by local NRCS Standards and Specifications guidance.

#### *Specifications Pertaining to Sand Filters Designed Underground*

Provide manhole and/or grates to all underground and below grade structures. Manholes shall be in compliance with standard specifications for each jurisdiction but diameters should be 30in minimum (to comply with OSHA confined space requirements) but not too heavy to lift. Aluminum and steel louvered doors are also acceptable. Ten-inch long (minimum) manhole steps (12in o.c.) shall be cast in place or drilled and mortared into the wall below each manhole. A 5ft minimum height clearance (from the top of the sand layer to the bottom of the slab) is required for all permanent underground structures. Lift rings are to be supplied to remove/replace top slabs. Manholes may need to be grated to allow for proper ventilation; if required, place manholes *away* from areas of heavy pedestrian traffic.

Underground sand filters shall be constructed with a dewatering gate valve located just above the top of the filter bed should the bed clog.

Underground sand beds shall be protected from trash accumulation by a wide mesh geotextile screen to be placed on the surface of the sand bed; screen is to be rolled up, removed, cleaned and re-installed during maintenance operations.

**Table 6.10 Material Specifications for Sand Filters**

Parameter	Specification	Size	Notes
Sand	clean AASHTO M-6 or ASTM C-33 concrete sand	0.02” to 0.04”	Sand substitutions such as Diabase and Graystone #10 are not acceptable. Crushed and washed limestone that meets the technical specifications of ASTM C-33 is acceptable.
Peat	ash content: < 15% pH range: 5.2 to 4.9 loose bulk density 0.12 to 0.15 g/cc	n/a	The material must be Reed-Sedge Hemic Peat, shredded, uncompacted, uniform, and clean.
Underdrain gravel	AASHTO M-43	0.25” to 0.75”	
Geotextile Fabric (if required)	ASTM D-751 (puncture strength - 125 lb.) ASTM D-1117 (Mullen Burst Strength - 400 psi) ASTM D-1682 (Tensile Strength - 300 lb.)	0.08” thick equivalent opening size of #80 sieve	Must maintain 125 gpm per sq. ft. flow rate. Note: a 4” washed, rounded limestone aggregate layer may be substituted for geotextiles meant to separate filter layers.
Impermeable Liner (if required)	ASTM D 751 (thickness) ASTM D 412 (tensile strength 1,100 lb., elongation 200%) ASTM D 624 (Tear resistance - 150 lb./in) ASTM D 471 (water adsorption: +8 to -2% mass)	30 mil thickness	Liner to be ultraviolet resistant. A geotextile fabric should be used to protect the liner from puncture.
Underdrain Piping	ASTM D-1785 or AASHTO M-278	4-6” rigid schedule 40 PVC	3/8” perf. @ 6” on center, 4 holes per row; minimum of 3” of limestone aggregate over pipes; not necessary underneath pipes
Concrete (Cast-in-place)	See Commonwealth (Territory) Standards and Specs. f’c = 3500 psi, normal weight, air-entrained; re-enforcing to meet ASTM 615-60	n/a	on-site testing of poured-in-place concrete required: 28 day strength and slump test; all concrete design (cast-in-place or pre-cast) <i>not using previously approved Commonwealth (Territory) standards</i> requires design drawings sealed and approved by a licensed professional structural engineer.
Concrete (pre-cast)	per pre-cast manufacturer	n/a	SEE ABOVE NOTE
non-rebar steel	ASTM A-36	n/a	structural steel to be hot-dipped galvanized ASTM A123

**<This page left blank intentionally>**



**Table 6.11 Sand/Organic Filter System Construction Inspection Checklist**

**Project:**

**Location:**

**Site Status:**

**Date:**

**Time:**

**Inspector:**

CONSTRUCTION SEQUENCE	SATISFACTORY / UNSATISFACTORY	COMMENTS
<b>1. Pre-construction</b>		
Pre-construction meeting		
Runoff diverted		
Facility area cleared		
Facility location staked out		
<b>2. Excavation</b>		
Size and location		
Side slopes stable		
Foundation cleared of debris		
If designed as exfilter, excavation does not compact subsoils		
Foundation area compacted		
<b>3. Structural Components</b>		
Dimensions and materials		
Forms adequately sized		
Concrete meets standards		
Prefabricated joints sealed		
Underdrains (size, materials)		

CONSTRUCTION SEQUENCE	SATISFACTORY / UNSATISFACTORY	COMMENTS
<b>4. Completed Facility Components</b>		
24-hour water filled test		
Contributing area stabilized		
Filter material per specification		
Underdrains installed to grade		
Flow diversion structure properly installed		
Pretreatment devices properly installed		
Level overflow weirs, multiple orifices, distribution slots		
<b>5. Final Inspection</b>		
Dimensions		
Surface completely level		
Structural components		
Proper outlet		
Ensure that site is properly stabilized before flow is directed to the structure.		

**Comments:**

---



---



---



---



---

**Actions to be Taken:**

---



---



---



---

## Construction Specifications for Bioretention Systems

### *Material Specifications*

The allowable materials to be used in bioretention area are detailed in **Table 6.12**.

### *Planting Soil*

The soil should be a uniform mix, free of stones, stumps, roots or other similar objects larger than two inches. No other materials or substances should be mixed or dumped within the bioretention area that may be harmful to plant growth, or prove a hindrance to the planting or maintenance operations. The planting soil should be free of noxious weeds.

The bioretention system shall utilize planting soil having a composition as follows:

Sand:	80%
Silt:	0 to 20%
Clay:	0 to 2%
Organic Matter*:	0 to 20%

\*Note: For bioretention applications with a planting soil depth of less than 4 feet, add 20% (by volume) of well aged (3 months), well aerated, leaf compost (or approved equivalent) to the above planting soil mixture. Where silt content is less than 20%, add a corresponding % of leaf compost.

The planting soil should be tested and should meet the following criteria:

pH range	5.2 - 7.0
magnesium	35 lb./ac
phosphorus P <sub>2</sub> O <sub>5</sub>	75 lb./ac
potassium K <sub>2</sub> O	85 lb./ac
soluble salts	not to exceed 500 ppm

All bioretention areas should have a minimum of one test. Each test should consist of both the standard soil test for pH, phosphorus, and potassium and additional tests of organic matter, and soluble salts. A textural analysis is required from the site's stockpiled topsoil. If topsoil is imported, then a texture analysis should be performed for each location where the top soil was excavated.

Since different labs calibrate their testing equipment differently, all testing results should come from the same testing facility.

Should the pH fall out of the acceptable range, it may be modified (higher) with lime or (lower) with iron sulfate plus sulfur.

### *Mulch Layer Specifications.*

Mulch around individual plants only. Shredded tangantangan, coconut fronds, or banana leaf mulch are the only accepted mulches. Bark dust mulches and wood chips will float and move to the perimeter of the bioretention area during a storm event and are not acceptable.

Shredded mulch must be well aged (6-12 months) for acceptance.

Mix approximately ½ the specified mulch layer into the planting soil to a depth of approximately 4 inches to help foster a highly organic surface layer.

### *Compaction*

It is very important to minimize compaction of both the base of the bioretention area and the required backfill. When possible, use excavation hoes to remove original soil. If bioretention area is excavated using a loader, the contractor should use wide track or marsh track equipment, or light equipment with turf type tires. Use of equipment with narrow tracks or narrow tires, rubber tires with large lugs, or high pressure tires will cause excessive compaction resulting in reduced infiltration rates and storage volumes and is not acceptable. Compaction will significantly contribute to design failure.

Compaction can be alleviated at the base of the bioretention facility by using a primary tilling operation such as a chisel plow, ripper, or subsoiler. These tilling operations are performed to refracture the soil profile through the 12-in compaction zone. Substitute methods must be approved by the engineer. Rototillers typically do not till deep enough to reduce the effects of compaction from heavy equipment.

When backfilling the bioretention facility, place soil in lifts 12in or greater. Do not use heavy equipment within the bioretention basin. Heavy equipment can be used around the perimeter of the basin to supply soils and sand. Grade bioretention materials with light equipment such as a compact loader or a dozer/loader with marsh tracks.

### *Plant Installation*

The plant root ball should be planted so 1/8<sup>th</sup> of the ball is above final grade surface. Root stock of the plant material should be kept moist during transport and on-site storage. The diameter of the planting pit should be at least six inches larger than the diameter of the planting ball. Set and maintain the plant straight during the entire planting process. Thoroughly water ground bed cover after installation.

Trees should be braced using 2in x 2in stakes only as necessary and for the first growing season only. Stakes are to be equally spaced on the outside of the tree ball.

Grasses and legume seed should be tilled into the soil to a depth of at least one inch. Grass and legume plugs should be planted following the non-grass ground cover planting specifications.

The planting soil specifications provide enough organic material to adequately supply nutrients from natural cycling. The primary function of the bioretention structure is to improve water quality. Adding fertilizers defeats, or at a minimum, impedes this goal. Only add fertilizer if compost or mulch is used to amend the soil. Rototill urea fertilizer at a rate of 2 pounds per 1,000 square feet.

### *Underdrains*

Underdrains should be placed on a minimum 3'-0" wide section of filter cloth. Pipe is placed next, followed by the limestone aggregate bedding. The ends of underdrain pipes not terminating in an observation well should be capped.

The main collector pipe for underdrain systems should be constructed at a minimum slope of 0.5%. Observation wells and/or clean-out pipes must be provided (one minimum per every 1,000 square feet of surface area, see plans for location).

### *Miscellaneous*

The bioretention facility may not be constructed until all contributing drainage area has been stabilized.

**Table 6.12 Materials Specifications for Bioretention**

Parameter	Specification	Size	Notes
<b>Planting Soil</b>	sand 80% silt 0 - 20% clay 0 - 2% organics 0 - 20%	n/a	USDA soil types loamy sand or sandy loam
<b>Mulch</b>	shredded tangantangan brush, coconut fronds, or banana leaves		aged 6 months, minimum
<b>Geotextile</b>	Class “C” apparent opening size (ASTM-D-4751) grab tensile strength (ASTM-D-4632) burst strength (ASTM-D-4833)	n/a	for use as necessary beneath underdrains only
<b>underdrain gravel</b>	AASHTO M-43	0.375” to 0.75”	
<b>underdrain piping</b>	ASTM D 1785 or AASHTO M-278	4 to 6” rigid schedule 40 PVC	3/8” perf. @ 6” on center, 4 holes per row; minimum of 3” of gravel/limestone aggregate over pipes; not necessary underneath pipes
<b>poured in place concrete (if required)</b>	See Federal Highway Admin. Standards and Specs.; f’c = 3,500 lb. @ 28 days, normal weight, air-entrained; re-enforcing to meet ASTM 615-60	n/a	on-site testing of poured-in-place concrete required: 28-day strength and slump test; all concrete design (cast-in-place or pre-cast) <i>not using previously approved standards</i> requires design drawings sealed and approved by a licensed professional structural engineer.
<b>sand (1’ deep)</b>	AASHTO M-6 or ASTM C-33	0.02” to 0.04”	Sand substitutions such as Diabase and Graystone #10 are not acceptable. Crushed and washed limestone that meets the technical specifications of ASTM C-33 is acceptable.

**Table 6.13 Bioretention Construction Inspection Checklist****Project:****Location:****Site Status:****Date:****Time:****Inspector:**

CONSTRUCTION SEQUENCE	SATISFACTORY/ UNSATISFACTORY	COMMENTS
<b>1. Pre-Construction</b>		
Pre-construction meeting		
Runoff diverted		
Facility area cleared		
If designed as exfilter, soil testing for permeability		
Facility location staked out		
<b>2. Excavation</b>		
Size and location		
Lateral slopes completely level		
If designed as exfilter, ensure that excavation does not compact subsoils.		
Longitudinal slopes within design range		
<b>3. Structural Components</b>		
Stone diaphragm installed correctly		
Outlets installed correctly		

CONSTRUCTION SEQUENCE	SATISFACTORY/ UNSATISFACTORY	COMMENTS
Underdrain		
Pretreatment devices installed		
Soil bed composition and texture		
<b>4. Vegetation</b>		
Complies with planting specs		
Topsoil adequate in composition and placement		
Adequate erosion control measures in place		
<b>5. Final Inspection</b>		
Dimensions		
Proper stone diaphragm		
Proper outlet		
Soil/ filter bed permeability testing		
Effective stand of vegetation and stabilization		
Construction generated sediments removed		
Contributing watershed stabilized before flow is diverted to the practice		





**<This page left blank intentionally>**

## 6.5 Construction Standards/Specifications for Open Channels

### *Material Specifications*

The recommended construction materials for open channels and filter strips are detailed in **Table 6.14**.

### *Dry Swales*

Roto-till soil/gravel interface approximately 6in to avoid a sharp soil/gravel interface.

Permeable soil mixture (20in to 30in deep) should meet the bioretention planting soil specifications.

Check dams, if required, shall be placed as specified.

System to have 6in of freeboard, minimum.

Side slopes to be 3:1 minimum; (4:1 or greater preferred).

No gravel or perforated pipe is to be placed under driveways.

Bottom of facility should be at least 2 ft above the seasonably high water table.

Seed with flood/drought resistant grasses; see your local NRCS Standards and Specifications guidance.

Longitudinal slope to be 1 to 2%, maximum (up to 5% with check dams).

Bottom width to be 6ft maximum to avoid braiding; larger widths may be used if proper berming is supplied (i.e., barrier between minimum widths). Width to be 2ft minimum.

### *Wet Swales*

Follow above information for dry swales, with the following exceptions: the seasonally high water table may inundate the swale; but not above the design bottom of the channel [NOTE: if the water table is stable within the channel; the  $WQ_v$  storage may start at this point]

Excavate into undisturbed soils; do not use an underdrain system.

### *Filter Strips*

Construct washed, rounded limestone aggregate diaphragms 12in wide, minimum, and 24in deep minimum.

Pervious berms to be a sand/gravel mix (35-60% sand, 30-55% silt, and 10-25% gravel). Berms to have overflow weirs with 6-in minimum head.

Slope range to be 2% minimum to 6% maximum.

**Table 6.14 Open Channel Materials Specifications**

Parameter	Specification	Size	Notes
Dry swale soil	sand 80% silt 0 - 20% clay 0 - 2% organics 0 - 20%	n/a	USDA soil types loamy sand or sandy loam, soil with a higher percent organic content is preferred
Dry swale sand	ASTM C-33 fine aggregate concrete sand	0.02in to 0.04in	Crushed, washed limestone that meets the technical specifications of ASTM C-33 is acceptable.
Check Dam (pressure treated)	AWPA Standard C6	6in x 6in or 8in x 8in	<i>do not</i> coat with creosote; embed at least 3ft into side slopes
Check Dam (natural wood)		6in to 12in diameter; notch as necessary	<i>do not</i> use species that have a predisposition towards rot
Filter Strip sand/gravel pervious berm	sand: per dry swale sand gravel; AASHTO M-43	sand: 0.02in to 0.04in gravel: 2in to 1in	mix with approximately 25% loam soil to support grass cover crop; see Bioretention planting soil notes for more detail.
Gravel diaphragm and curtain drain	ASTM D 448	varies (No. 6) or (1/8in to 3/8in)	use washed, rounded limestone aggregate as a substitute
underdrain gravel	AASHTO M-43	0.25in to 0.75in	
underdrain	ASTM D -1785 or AASHTO M-278	4-6in rigid Schedule 40 PVC	3/8in perf. @ 6in o.c.; 4 holes per row
Geotextile	See Federal Highway Admin. Standards and Specs	n/a	
rip rap	per Federal Highway Admin. criteria	size per Federal Highway Admin. requirements	

**Table 6.15 Open Channel System Construction Inspection Checklist**

**Project:**

**Location:**

**Site Status:**

**Date:**

**Time:**

**Inspector:**

CONSTRUCTION SEQUENCE	SATISFACTORY / UNSATISFACTORY	COMMENTS
<b>1. Pre-Construction</b>		
Pre-construction meeting		
Runoff diverted		
Facility location staked out		
<b>2. Excavation</b>		
Size and location		
Side slope stable		
Soil permeability		
Groundwater / bedrock		
Lateral slopes completely level		
Longitudinal slopes within design range		
Excavation does not compact subsoils		
<b>3. Check dams</b>		
Dimensions		
Spacing		
Materials		

CONSTRUCTION SEQUENCE	SATISFACTORY / UNSATISFACTORY	COMMENTS
<b>4. Structural Components</b>		
Underdrain installed correctly		
Inflow installed correctly		
Pretreatment devices installed		
<b>5. Vegetation</b>		
Complies with planting specifications		
Topsoil adequate in composition and placement		
Adequate erosion control measures in place		
<b>6. Final inspection</b>		
Dimensions		
Check dams		
Proper outlet		
Effective stand of vegetation and stabilization		
Contributing watershed stabilized before flow is routed to the facility		

**Comments:**

---



---



---



---



---



---



---



---

**Actions to be Taken:**

---

---

---

---

---

---

---

---

---

---

---

**<This page left blank intentionally>**





## **7.0**    *Maintenance Plans*

An essential component of a successful stormwater system is the ongoing operation and maintenance of the various components of the stormwater drainage, control, and conveyance systems. Failure to provide effective maintenance can reduce the hydraulic capacity and the pollutant removal efficiency of stormwater practices.

Many people expect that stormwater facilities will continue to function correctly as designed forever. However, it is inevitable that deterioration of the stormwater infrastructure will occur once it becomes operational. The question is not whether stormwater management system maintenance is necessary. Ideally, a program should address operations and maintenance concerns proactively instead of reacting to problems that occur such as flooding or water quality degradation. Thus, on-going maintenance is a vital part of ensuring the operational success of stormwater management facilities and is critical to achieving an extended service life of continuous operation as designed.

There are two key components to adequately maintaining a stormwater management infrastructure:

- Periodic and scheduled inspections, and
- Maintenance scheduling and performance

### Inspections

It is clear that an inspection program is necessary to ensure a stormwater facility remains operational. Inspections should be performed on a regular basis and scheduled based on the stormwater control type and characteristics. In addition, inspections should occur after major rainfall events for those components deemed to be critically affected by the resulting runoff. Not all inspections can be conducted by direct human observation. For subsurface systems, video equipment may be required. There may be cases where other specialized equipment is necessary. The inspection program should be tailored to address the operational characteristics of the system.

It is not mandatory that all inspectors be trained engineers, but they should have some knowledge or experience with stormwater systems. Trained stormwater engineers should, however, direct them. Inspections by registered engineers should be performed where routine inspection has revealed a question of structural or hydraulic integrity affecting public safety.

The inspection process should document observations made in the field. Comments should be archived on structural conditions, hydraulic operational conditions, evidence of vandalism, condition of vegetation, occurrence of obstructions, unsafe conditions, and build-up of trash, sediments and pollutants. This is also an efficient way to take water quality measurements required for monitoring programs and to incorporate them into the inspection history.

### Maintenance Scheduling and Performance

Maintenance activities can be divided into two types: scheduled and corrective. Scheduled maintenance tasks are those that are typically accomplished on a regular basis and can generally be scheduled without referencing inspection reports. These items consist of such things as vegetation maintenance (such as grass mowing) and trash and debris removal. These tasks are required at well-defined time intervals and can be considered a given for most, if not all, stormwater structural facilities. A permanent maintenance crew is typically put under a fixed scope of responsibility to address these items.

Corrective tasks consist of items such as sediment removal, stream bank stabilization, and outlet structure repairs that are done on an as-needed basis. These tasks are typically scheduled based on inspection results or in response to complaints. Corrective maintenance sometimes calls for more specialized expertise and equipment than for scheduled tasks. For example, a task such as sediment removal from a stormwater pond requires specialized equipment for which not every jurisdiction is willing to invest. Therefore, some maintenance tasks might be effectively handled on a contract basis with an outside entity specializing in that field. In addition, some corrective maintenance may also require a formal design and bid process to accomplish the work.

The following section describes appropriate maintenance and inspection activities for the acceptable best management practices.

## **7.1 Maintenance Descriptions and Guidance**

A stormwater control system should be regularly inspected to ensure proper performance and to prevent deficiencies in the effectiveness of the systems due to sediment build-up, damage, or deterioration. The following operation and maintenance provisions should be provided:

### **Ponds and Wetlands**

General inspections should be conducted on an annual basis and after storm events of greater than or equal the 1-year precipitation event (approximately 3.5 inches in northern Guam). Areas with a permanent pool should be inspected on a semi-annual basis. The maintenance objective for these practices includes preserving the hydraulic and removal efficiency of the pond or wetland and maintaining the structural integrity.

The slopes of the pond or wetland should be inspected for erosion and gulying. Reinforce existing riprap if riprap is found to be deficient, erosion is present at the outfalls of any control structures, or the existing riprap has been compromised. All structural components, which include but not limited to trash racks, access gates, valves, pipes, weir walls, orifice structures and spillway structures, should be inspected and any deficiencies should be reported. This includes a visual inspection of all stormwater control structures for damage and/or accumulation

of sediment. Sediment should be removed from the forebay when design depth has been reduced by 50%. All material, including any trash and/or debris from all areas within the extents of the pond or wetland area including trash rack and flow control structures, should be disposed of in accordance with all federal and local regulations.

Any areas within the extents of the stormwater facility that are subject to erosion or gulying should be replenished with the original design material and re-vegetated according to design drawings. Slope protection material shall be placed in areas prone to erosion, in accordance with the above specifications. Embankment stability shall be inspected for seepage and burrowing animals.

Mow the grass around the perimeter of the pond or wetland at least 4 times annually. Prune all dead or dying vegetation within the extents of the pond or wetland, remove all herbaceous vegetation root stock when overcrowding the maintenance access to the facility, remove any vegetation that has a negative impact on stormwater flowage through the facility and trim any overgrown vegetation within the basin. Any invasive vegetation encroaching upon the perimeter of the facility shall be pruned or removed if it is prohibiting access to the facility, compromising sight visibility and/or compromising original design vegetation. Replace any/all original vegetation that has died off or has not fully established, as determined at the time of the inspection. Wetland vegetation should be reinforced to its original design standards if less than 50% of the original vegetation is established after two years.

### **Infiltration**

Infiltration facilities should be inspected annually to ensure that design infiltration rates are being met. If sediment or organic debris build-up has limited the infiltration capabilities (infiltration basins) to below the design rate, the top 6 inches should be removed and the surface roto-tilled to a depth of 12 inches. The basin bottom should be restored according to original design specifications. Any oil or grease found at the time of the inspection should be cleaned with oil absorption pads and disposed of in an approved location.

Inspect facility for signs of wetness or damage to structures and note any eroded areas. If dead or dying grass on the bottom is observed, check to ensure that water percolates 2-3 days following storms. Mow and remove litter and debris. Stabilize eroded banks and repair undercut and eroded areas at inflow and outflow structures.

### **Filters**

#### *Sand Filters*

Sand filters should be inspected annually and after storm events of greater than or equal the 1-year precipitation event. Open the access covers of the underground sand filters and make a visual inspection to determine the extents of maintenance necessary to rehabilitate the sand filter to its original design standards.

Proceed with the following if half of the entire sediment chamber depth is found to be full of sediment at the time of the inspection. All oil, sludge, sediment, solids, trash, debris and floatable material should be removed from all chambers of the sand filter. All stormwater within an underground sand filter shall be pumped out of the facility by means of a vacor truck. All

remaining oil and grit shall be removed from the face of the exposed concrete within the perimeter sand filter, including but not limited to the wet storage chamber, sand filter chamber and overflow chamber.

Materials deposited on the surface of the sand filter (e.g., trash and litter) should be removed manually. Clean-out shall be accomplished via catch vac or vactor truck. After cleaning, the cover and grate are to be reset and all resulting waste including oil, sludge, sediment, and water should be disposed of in accordance with all applicable federal and local regulations.

If standing water is observed more than 48 hours after a storm event, then the top 6 inches of sand should be removed and replaced with new materials. If discolored or contaminated material is found below this removed surface then that material should also be removed and replaced until all contaminated sand has been removed from the filter chamber. The sand should be disposed of in accordance with all applicable federal and local regulations.

All structural components, which include the outlet structure, valves, pipes, frame and grate, cover, underdrain system, and structural concrete, should be inspected and any deficiencies shall be reported.

#### *Bioretention*

Inspections are an integral part of system maintenance. During the six months immediately after construction, bioretention facilities should be inspected at least twice or more following precipitation events of at least 1.0 inch to ensure that the system is functioning properly. Thereafter, inspections should be conducted on an annual basis and after storm events of greater than or equal the 1-year precipitation event (approximately 3.5 inches in northern Guam).

Minor soil erosion gullies should be repaired when they occur. Pruning or replacement of woody vegetation should occur when dead or dying vegetation is observed. Separation of herbaceous vegetation root shock should occur when over-crowding is observed, or approximately once every 3 years. The mulch layer should also be replenished (to the original design depth) every other year as directed by inspection reports. The previous mulch layer should be removed, and properly disposed of, or roto-tilled into the soil surface. If at least 50 percent vegetation coverage is not established after two years, a reinforcement planting should be performed. If the surface of the bioretention system becomes clogged to the point that standing water is observed on the surface 48 hours after precipitation events, the surface should be roto-tilled or cultivated to breakup any hard-packed sediment and then re-vegetated.

#### **Open channels**

The maintenance objective for this practice includes preserving the hydraulic and removal efficiency of the channel and maintaining a dense, healthy vegetative cover. The following activities are recommended on an annual basis or as needed:

- Mowing and litter and debris removal;
- Stabilization of eroded side slopes and bottom;
- Nutrient and pesticide use management;
- De-thatching swale bottom and removal of thatching; and
- Discing or aeration of swale bottom.

Every five years, scraping of the channel bottom and removal of sediment to restore original cross section and infiltration rate, and seeding to restore ground cover is recommended.

Dry swales should be inspected on an annual basis and just after storms of greater than or equal to the 1-year precipitation event. Both the structural and vegetative components should be inspected and repaired. When sediment accumulates to a depth of approximately 3 inches, it should be removed, and the swale should be reconfigured to its original dimensions. The grass in the dry swale should be mowed at least 4 times during the year. If the surface of the dry swale becomes clogged to the point that standing water is observed in the surface 48 hours after precipitation events, the bottom should be roto-tilled or cultivated to break up any hard-packed sediment, and then reseeded. Trash and debris should be removed and properly disposed of.

Wet swales should be inspected annually and after storms of greater than or equal to the 1-year precipitation event. During inspection, the structural components of the system, including trash racks, valves, pipes and spillway structures, should be checked for proper function. Any clogged openings should be cleaned out and repairs should be made where necessary. Embankments should be checked for stability and any burrowing animals should be removed. Vegetation along the maintenance access roads should be mowed annually. Woody vegetation along those surfaces should be pruned where dead or dying branches are observed, and reinforcement plantings should be planted if less than 50 percent of the original vegetation establishes after two years. Sediment should be removed from the bottom of the swale.

**<This page left blank intentionally>**

## 7.2 Best Management Practices Operation, Maintenance, and Inspection Checklists

### Stormwater Pond/Wetland Operation, Maintenance and Management Inspection Checklist

**Project**

**Location:**

**Site Status:**

**Date:**

**Time:**

**Inspector:**

Maintenance Item	Satisfactory/ Unsatisfactory	Comments
<b>1. Embankment and emergency spillway (Annual, After Major Storms)</b>		
1. Vegetation and ground cover adequate		
2. Embankment erosion		
3. Animal burrows		
4. Unauthorized planting		
5. Cracking, bulging, or sliding of dam		
a. Upstream face		
b. Downstream face		
c. At or beyond toe		
downstream		
upstream		
d. Emergency spillway		
6. Pond, toe & chimney drains clear and functioning		

Maintenance Item	Satisfactory/ Unsatisfactory	Comments
7. Seeps/leaks on downstream face		
8. Slope protection or riprap failure		
9. Vertical/horizontal alignment of top of dam “As-Built”		
10. Emergency spillway clear of obstructions and debris		
11. Other (specify)		
<b>2. Riser and principal spillway (Annual)</b>		
Type: Reinforced concrete _____ Corrugated pipe _____ Masonry _____		
1. Low-flow orifice obstructed		
2. Low-flow trash rack. a. Debris removal necessary		
b. Corrosion control		
3. Weir trash rack maintenance a. Debris removal necessary		
b. corrosion control		
4. Excessive sediment accumulation inside riser		
5. Concrete/masonry condition riser and barrels a. cracks or displacement		
b. Minor spalling (<1" )		
c. Major spalling (rebars exposed)		
d. Joint failures		
e. Water tightness		
6. Metal pipe condition		
7. Control valve a. Operational/exercised		
b. Chained and locked		



Maintenance Item	Satisfactory/ Unsatisfactory	Comments
8. Pond drain valve a. Operational/exercised		
b. Chained and locked		
9. Outfall channels functioning		
10. Other (specify)		
<b>3. Permanent Pool (Wet Ponds) (Semi-annually)</b>		
1. Undesirable vegetative growth		
2. Floating or floatable debris removal required		
3. Visible pollution		
4. Shoreline problem		
5. Other (specify)		
<b>4. Sediment Forebays</b>		
1. Sedimentation noted		
2. Sediment cleanout when depth < 50% design depth		
<b>5. Dry Pond Areas</b>		
1. Vegetation adequate		
2. Undesirable vegetative growth		
3. Undesirable woody vegetation		
4. Low-flow channels clear of obstructions		
5. Standing water or wet spots		
6. Sediment and/or trash accumulation		
7. Other (specify)		
<b>6. Condition of Outfalls (Annual , After Major Storms)</b>		
1. Riprap failures		
2. Slope erosion		
3. Storm drain pipes		

Maintenance Item	Satisfactory/ Unsatisfactory	Comments
4. Endwalls / Headwalls		
5. Other (specify)		
<b>7. Other (Semi-annually)</b>		
1. Encroachment on pond, wetland or easement area		
2. Complaints from residents		
3. Aesthetics a. Grass growing required		
b. Graffiti removal needed		
c. Other (specify)		
4. Conditions of maintenance access routes.		
5. Signs of hydrocarbon build-up		
6. Any public hazards (specify)		
<b>8. Wetland Vegetation (Annual)</b>		
1. Vegetation healthy and growing Wetland maintaining 50% surface area coverage of wetland plants after the second growing season. (If unsatisfactory, reinforcement plantings needed)		
2. Dominant wetland plants: Survival of desired wetland plant species Distribution according to landscaping plan?		
3. Evidence of invasive species		
4. Maintenance of adequate water depths for desired wetland plant species		
5. Harvesting of emergent plantings needed		
6. Have sediment accumulations reduced pool volume significantly or are plants “choked” with sediment		
7. Eutrophication level of the wetland.		
8. Other (specify)		

**Comments:**

---

---

---

---

---

---

**Actions to be Taken:**

---

---

---

---

---

**<This page left blank intentionally>**

**Infiltration System Operation, Maintenance, and  
Management Inspection Checklist**

**Project:**

**Location:**

**Site Status:**

**Date:**

**Time:**

**Inspector:**

MAINTENANCE ITEM	SATISFACTORY / UNSATISFACTORY	COMMENTS
<b>1. Debris Cleanout (Semi-annually)</b>		
Trench/chamber or basin surface clear of debris		
Inflow pipes clear of debris		
Overflow spillway clear of debris		
Inlet area clear of debris		
<b>2. Sediment Traps or Forebays (Annual)</b>		
Obviously trapping sediment		
Greater than 50% of storage volume remaining		
<b>3. Dewatering (Semi-annually)</b>		
Trench/chamber or basin dewatered between storms		
<b>4. Sediment Cleanout of Trench/Chamber or Basin (Annual)</b>		
No evidence of sedimentation in trench/chamber or basin		

MAINTENANCE ITEM	SATISFACTORY / UNSATISFACTORY	COMMENTS
Sediment accumulation doesn't yet require cleanout		
<b>5. Inlets (Annual)</b>		
Good condition		
No evidence of erosion		
<b>6. Outlet/Overflow Spillway (Annual)</b>		
Good condition, no need for repair		
No evidence of erosion		
<b>7. Aggregate Repairs (Annual)</b>		
Surface of aggregate clean		
Top layer of stone does not need replacement		
Trench/Chamber or basin does not need rehabilitation		

**Comments:**

---



---



---



---

**Actions to be Taken:**

---



---



---



---



---

**Sand/Organic Filter Operation, Maintenance  
and Management Inspection Checklist**

**Project:**

**Location:**

**Site Status:**

**Date:**

**Time:**

**Inspector:**

MAINTENANCE ITEM	SATISFACTORY / UNSATISFACTORY	COMMENTS
<b>1. Debris Cleanout (Semi-annually)</b>		
Contributing areas clean of debris		
Filtration facility clean of debris		
Inlet and outlets clear of debris		
<b>2. Oil and Grease (Monthly)</b>		
No evidence of filter surface clogging		
Activities in drainage area minimize oil and grease entry		
<b>3. Vegetation (Semi-annually)</b>		
Contributing drainage area stabilized		
No evidence of erosion		
Area mowed and clipping removed		
<b>4. Water Retention Where Required (Semi-annually)</b>		
Water holding chambers at normal pool		

MAINTENANCE ITEM	SATISFACTORY / UNSATISFACTORY	COMMENTS
No evidence of leakage		
<b>5. Sediment Deposition (Annual)</b>		
Filter chamber free of sediments		
Sedimentation chamber not more than half full of sediments		
<b>6. Structural Components (Annual)</b>		
No evidence of structural deterioration		
Any grates are in good condition		
No evidence of spalling or cracking of structural parts		
<b>7. Outlet/Overflow Spillway (Annual)</b>		
Good condition, no need for repairs		
No evidence of erosion (if draining into a natural channel)		
<b>8. Overall Function of Facility (Annual)</b>		
Evidence of flow bypassing facility		
No noticeable odors outside of facility		

**Comments:**

---



---



---



---



---



---



**Actions to be Taken:**

---

---

---

---

---

---

---

**<This page left blank intentionally>**

**Bioretention Operation, Maintenance and Management Inspection Checklist**

**Project:**

**Location:**

**Site Status:**

**Date:**

**Time:**

**Inspector:**

MAINTENANCE ITEM	SATISFACTORY / UNSATISFACTORY	COMMENTS
<b>1. Debris Cleanout (Semi-annually)</b>		
Bioretention and contributing areas clean of debris		
No dumping of yard wastes into practice		
Litter (branches, etc.) have been removed		
<b>2. Vegetation (Semi-annually)</b>		
Plant height not less than design water depth		
Fertilized per specifications		
Plant composition according to approved plans		
No placement of inappropriate plants		
Grass height not greater than 10 inches		
No evidence of erosion		

MAINTENANCE ITEM	SATISFACTORY / UNSATISFACTORY	COMMENTS
<b>3. Check Dams/Energy Dissipaters/Sumps (Annual, After Major Storms)</b>		
No evidence of sediment buildup		
Sumps should not be more than 50% full of sediment		
No evidence of erosion at downstream toe of drop structure		
<b>4. Dewatering (Semi-annually)</b>		
Dewaters between storms		
No evidence of standing water		
<b>5. Sediment Deposition (Annual)</b>		
Swale clean of sediments		
Sediments should not be > 20% of swale design depth		
<b>6. Outlet/Overflow Spillway (Annual, After Major Storms)</b>		
Good condition, no need for repair		
No evidence of erosion		
No evidence of any blockages		
<b>7. Integrity of Filter Bed (Annual)</b>		
Filter bed has not been blocked or filled inappropriately		

**Comments:**

---



---



---



---



---

---

**Actions to be Taken:**

---

---

---

---

---

---

---

**<This page left blank intentionally>**

**Open Channel Operation, Maintenance, and  
Management Inspection Checklist**

**Project:**

**Location:**

**Site Status:**

**Date:**

**Time:**

**Inspector:**

MAINTENANCE ITEM	SATISFACTORY/ UNSATISFACTORY	COMMENTS
<b>1. Debris Cleanout (Semi-annually)</b>		
Contributing areas clean of debris		
<b>2. Check Dams or Energy Dissipators (Annual, After Major Storms)</b>		
No evidence of flow going around structures		
No evidence of erosion at downstream toe		
Soil permeability		
Groundwater / bedrock		
<b>3. Vegetation (Semi-annually)</b>		
Mowing done when needed		
Minimum mowing depth not exceeded		
No evidence of erosion		
Fertilized per specification		
<b>4. Dewatering (Semi-annually)</b>		
Dewaters between storms		

MAINTENANCE ITEM	SATISFACTORY/ UNSATISFACTORY	COMMENTS
<b>5. Sediment deposition (Annual)</b>		
Clean of sediment		
<b>6. Outlet/Overflow Spillway (Annual)</b>		
Good condition, no need for repairs		
No evidence of erosion		

**Comments:**

---

---

---

---

---

---

---

---

**Actions to be Taken:**

---

---

---

---

---

---

---

---



### 7.3 Maintenance Agreements

A major contributor to unmaintained stormwater facilities is a lack of clear ownership and responsibility definition. In order for an inspection and maintenance program to be effective, the roles for each responsibility must be clearly defined prior to construction of a system. This can be accomplished with a maintenance agreement between the site owners and the local authority.

Some key aspects of these maintenance agreements are the clear delineation of responsibilities, such as:

- Identification of who will perform inspection duties and how often.
- Listed duties that are to be performed by the owner, such as mowing, debris removal, and replanting of vegetation.
- Defined roles for the local authority, possibly inspection, and/or modifications to the system such as resizing an orifice.
- Determination of a course of action to be taken if the owner does not fulfill their obligations (i.e. repayment to the local authority for activities that the owner did not perform).
- Development of a pollution prevention plan by the owner.
- Requirement of a report, possibly annually, that would serve to keep the owner involved and aware of their responsibilities.

A sample maintenance agreement is included below.

## Sample Stormwater Facility Maintenance Agreement

THIS AGREEMENT, made and entered into this \_\_\_ day of \_\_\_\_\_, 20\_\_\_, by and between (Insert Full Name of Owner) \_\_\_\_\_ hereinafter called the "Landowner", and the [Local Jurisdiction], hereinafter called the "[Territory/Commonwealth]". WITNESSETH, that WHEREAS, the Landowner is the owner of certain real property described as (Tax Map/Parcel Identification Number) \_\_\_\_\_ as recorded by deed in the land records of [Local Jurisdiction] Deed Book \_\_\_\_\_ Page \_\_\_\_\_, hereinafter called the "Property".

WHEREAS, the Landowner is proceeding to build on and develop the property; and WHEREAS, the Site Plan/Subdivision Plan known as \_\_\_\_\_, (Name of Plan/Development) hereinafter called the "Plan", which is expressly made a part hereof, as approved or to be approved by the [Territory/Commonwealth], provides for detention of stormwater within the confines of the property; and

WHEREAS, the [Territory/Commonwealth] and the Landowner, its successors and assigns, including any homeowners association, agree that the health, safety, and welfare of the residents of [Local Jurisdiction] require that on-site stormwater management facilities be constructed and maintained on the Property; and

WHEREAS, the [Territory/Commonwealth] requires that on-site stormwater management facilities as shown on the Plan be constructed and adequately maintained by the Landowner, its successors and assigns, including any homeowners association.

NOW, THEREFORE, in consideration of the foregoing premises, the mutual covenants contained herein, and the following terms and conditions, the parties hereto agree as follows:

1. The on-site stormwater management facilities shall be constructed by the Landowner, its successors and assigns, in accordance with the plans and specifications identified in the Plan.
2. The Landowner, its successors and assigns, including any homeowners association, shall adequately maintain the stormwater management facilities. This includes all pipes, channels or other conveyances built to convey stormwater to the facility, as well as all structures, improvements, and vegetation provided to control the quantity and quality of the stormwater. Adequate maintenance is herein defined as good working condition so that these facilities are performing their design functions. The Stormwater Best Management Practices Operation, Maintenance and Management Checklists are to be used to establish what good working condition is acceptable to the [Territory/Commonwealth].

3. The Landowner, its successors and assigns, shall inspect the stormwater management facility and submit an inspection report annually. The purpose of the inspection is to assure safe and proper functioning of the facilities. The inspection shall cover the entire facilities, berms, outlet structure, pond areas, access roads, etc. Deficiencies shall be noted in the inspection report.

4. The Landowner, its successors and assigns, hereby grant permission to the [Territory/Commonwealth], its authorized agents and employees, to enter upon the Property and to inspect the stormwater management facilities whenever the [Territory/Commonwealth] deems necessary. The purpose of inspection is to follow-up on reported deficiencies and/or to respond to citizen complaints. The [Territory/Commonwealth] shall provide the Landowner, its successors and assigns, copies of the inspection findings and a directive to commence with the repairs if necessary.

5. In the event the Landowner, its successors and assigns, fails to maintain the stormwater management facilities in good working condition acceptable to the [Territory/Commonwealth], the [Territory/Commonwealth] may enter upon the Property and take whatever steps necessary to correct deficiencies identified in the inspection report and to charge the costs of such repairs to the Landowner, its successors and assigns. This provision shall not be construed to allow the [Territory/Commonwealth] to erect any structure of permanent nature on the land of the Landowner outside of the easement for the stormwater management facilities. It is expressly understood and agreed that the [Territory/Commonwealth] is under no obligation to routinely maintain or repair said facilities, and in no event shall this Agreement be construed to impose any such obligation on the [Territory/Commonwealth].

6. The Landowner, its successors and assigns, will perform the work necessary to keep these facilities in good working order as appropriate. In the event a maintenance schedule for the stormwater management facilities (including sediment removal) is outlined on the approved plans, the schedule will be followed.

7. In the event the [Territory/Commonwealth] pursuant to this Agreement, performs work of any nature, or expends any funds in performance of said work for labor, use of equipment, supplies, materials, and the like, the Landowner, its successors and assigns, shall reimburse the [Territory/Commonwealth] upon demand, within thirty (30) days of receipt thereof for all actual costs incurred by the [Territory/Commonwealth] hereunder.

8. This Agreement imposes no liability of any kind whatsoever on the [Territory/Commonwealth] and the Landowner agrees to hold the [Territory/Commonwealth] harmless from any liability in the event the stormwater management facilities fail to operate properly.

9. This Agreement shall be recorded among the land records of [Local Jurisdiction] and shall constitute a covenant running with the land, and shall be binding on the Landowner, its administrators, executors, assigns, heirs and any other successors in interests, including any homeowners association.

WITNESS the following signatures and seals:

\_\_\_\_\_  
Company/Corporation/Partnership Name (Seal)

By: \_\_\_\_\_

\_\_\_\_\_  
(Type Name and Title)

The foregoing Agreement was acknowledged before me this \_\_\_\_ day of \_\_\_\_\_, 20 \_\_\_\_,  
by

\_\_\_\_\_.

\_\_\_\_\_  
NOTARY PUBLIC

My Commission Expires: \_\_\_\_\_

By: \_\_\_\_\_

\_\_\_\_\_  
(Type Name and Title)

The foregoing Agreement was acknowledged before me this \_\_\_\_ day of \_\_\_\_\_, 20 \_\_\_\_,  
by

\_\_\_\_\_.

\_\_\_\_\_  
NOTARY PUBLIC

My Commission Expires: \_\_\_\_\_

Approved as to Form:

\_\_\_\_\_  
[Territory/Commonwealth] Attorney Date



## *8.0 Soils Information*

### **8.1 Introduction to Soils**

Soil is defined as weathered bedrock (parent material) that supports plant life and consists of distinguishable horizons or layers. Soil science is a complicated subject that would require at least a lengthy document to cover adequately. This section will focus on the basics of soils as it relates to stormwater management and how to determine soil characteristics in the field. A soil evaluator certification class will be provided in CNMI and Guam to familiarize engineers, contractors, and other interested parties with local soils and field techniques. In addition, the following references may be helpful for more detailed information on soils:

N.C. Brady and R.R. Weil. 2001. *The Nature and Property of Soils*, 13<sup>th</sup> ed. Prentice Hall, Upper Saddle River, NJ. 960 pp.

B.P.K. Yerima and E. Van Ranst. 2005. *Introduction to Soil Science: Soils of the Tropics*. Trafford Publishing, Victoria, B.C. 440 pp.

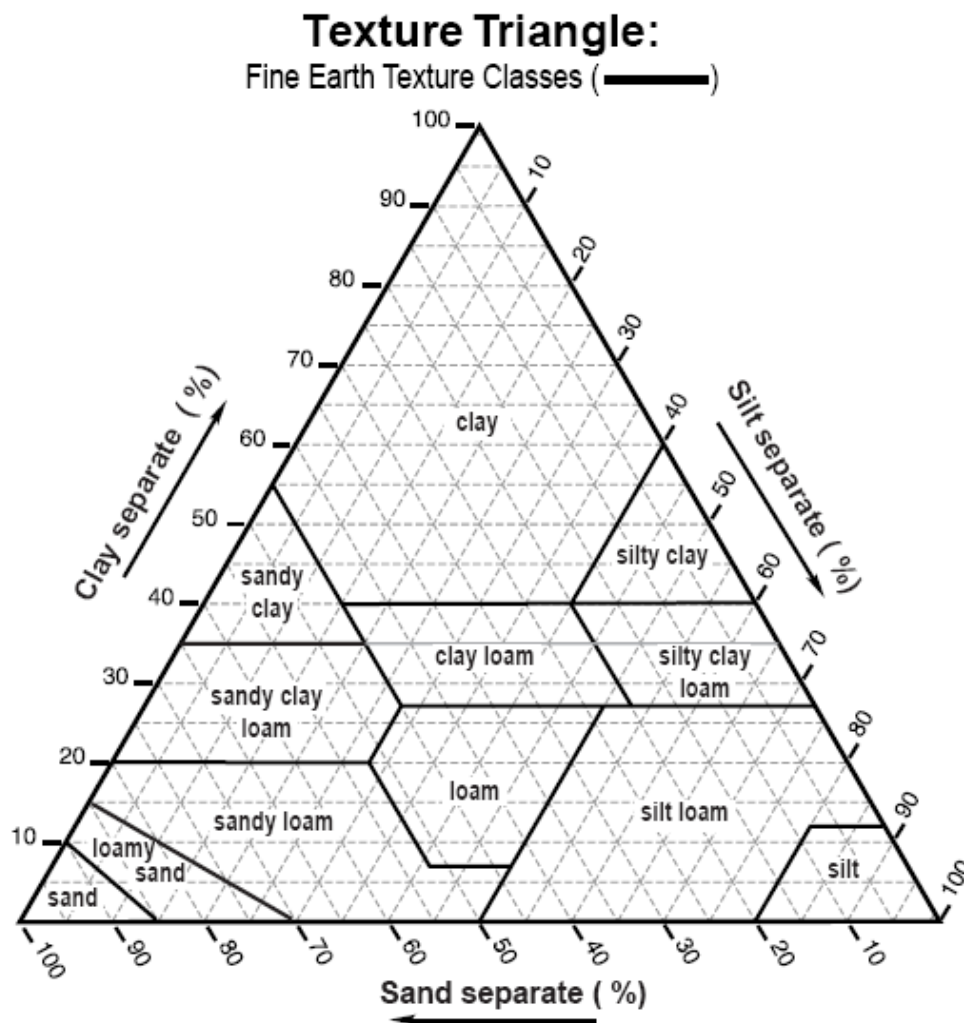
Soils are one of the most important site characteristics to consider when determining appropriate stormwater BMPs to use and their placement on a site. For example, infiltration facilities are not feasible in clayey, volcanic soils, and it may be difficult to sustain a permanent pool for a wet pond in sandy soils without a liner. A bioretention area may not work on a site with a high groundwater table.

One of the first steps when starting a project should be to review the NRCS Soil Survey. The Soil Survey includes a wealth of information about the soils and geology of the islands and must be used to determine the hydrologic soil group (HSG) in order to establish the recharge criteria for the site (**Volume I, Section 2.2.2.1**). Once a designer has a general idea about the soils and geology, a test pit should be performed in the field by a soil scientist or certified soil evaluator. A test pit is a deep observation hole typically dug by a backhoe, measuring a minimum of 3 ft wide and a minimum of 6 ft long. The test pit should be dug to a depth of 3 ft below the bottom of the BMP of interest, to groundwater, or to impervious material. A description of how to evaluate a test pit is included below in **Section 8.2**. In addition, the NRCS Field Book for Describing and Sampling Soils (Schoeneberger et al., 2002) has been included on the reference CD accompanying these manuals to be used as a field guide. Information on soil texture, depth of the soil profile, seasonal high groundwater, and type of parent material (e.g., limestone,

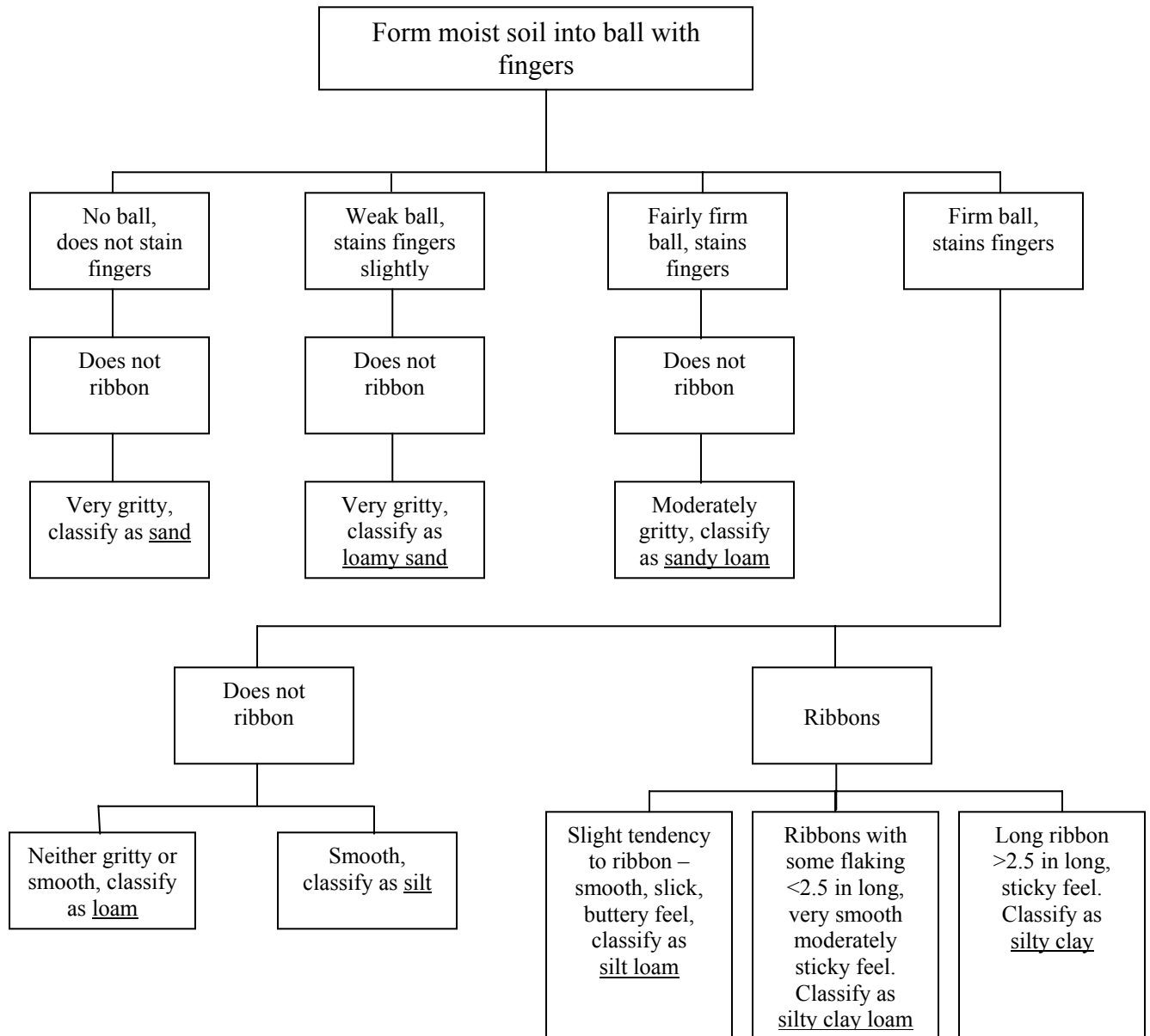
volcanics) is necessary before designing the stormwater management facilities for a site and can be gathered from a test pit.

*Soil Texture*

Soil texture refers to the relative proportions of sand, silt, and clay in a soil. For stormwater purposes, the USDA soil texture classification should be used (**Figure 8.1**) and must be determined in the field by a soil scientist or certified soil evaluator using the procedure shown in **Figure 8.2**. Soil texture is particularly important when establishing design infiltration rates (**Volume I, Table 3.5**).



**Figure 8.1** USDA Textural Classification Triangle



**Figure 8.2 Field Procedure for Determining USDA Textural Classification**

## 8.2 Test Pit Procedure

(based on information from the Plymouth Conservation District, USDA NRCS)

### Suggested Equipment List

- Soil color book
- Tape measure
- Trowel, knife, or small garden shovel
- Something to mark horizons and layers (large nails or golf tees)
- Soil sample tray (a plastic plate or muffin tin is acceptable)
- Spray water bottle
- Small towel to wipe hands
- Clipboard
- Soil field guide book
- Proper field clothing including umbrella, work boots, etc.
- Sun block, insect repellent, etc.



**Figure 8.3** Participants of the May 2006 Stormwater Training Workshop in Saipan learn how to evaluate a test pit.

### 1. Review Reference Materials

- USGS Topographic Map
- Surficial Geology Map: determine landform and parent material
- NRCS Published Soil Survey Reports: determine soil type, parent material, estimated depth to seasonal high water table
- Flood Insurance Maps: 100-year floodplain
- Others

### 2. Walk the Site

- Note the position on the landscape.
- Check for open water bodies, wetlands (especially wetland delineations), and water courses; note position of site relative to these areas.
- Look for rock outcrops, surface stones, etc.
- Check for prior land disturbance or alteration.
- Note changes in vegetation

### 3. Enter the Test Pit (follow local and federal safety rules)

- Clean all sides of the test pit to remove loose soil material.
- Stand back and observe all pit faces; note any variability within the pit.
- Determine the type of parent material (limestone or volcanics)
- Decide on a representative section of the pit and identify the different soil horizons and layers.



- Make special note of any changes observed on the different sides of the deep observation hole.
4. Describe and document the soil characteristics of each of the soil horizons and layers. Refer to the NRCS Field Book for Describing and Sampling Soils (Schoeneberger et al., 2002) and log the observations on a test pit form (**Figure 8.4**), both of which are included on the reference CD.

*Note: it often saves time and the results are more consistent when you describe one feature at a time.*

- Determine the soil matrix color for each soil horizon and layer.
  - Determine the soil texture for each soil horizon and layer.
  - Determine the % gravel for each soil horizon and layer.
  - Determine the soil consistence and soil structure for each soil horizon and layer.
5. Estimate the depth to the seasonal high water table

Make special note of the time of the year. Is it the wet season? What are the current water table conditions? Are they in the normal range or are they above or below normal.

- Keeping your “head out of the hole,” would you expect to see a water table and at what depth? For example, what is the relative elevation of where the test pit is located compared to wetlands and open water bodies?
- When you observe the water table, was water weeping from the sides of the deep hole or standing in the bottom of the pit?
- Reviewing your soil log, are there any restrictive layers that may impede the downward flow of water and perch water above it?
- Clean all sides of the pit and stand back to look for any patterns of redoximorphic<sup>1</sup> features that continue across the pit faces.
- Starting in the lower portion of the test pit, look for redoximorphic features. If there are redoximorphic features present, follow the pattern up the side of the test pit. Do this independently for each side of the test pit and then compare the results to see if they are consistent.
- Depth to seasonal high water table using soil features is where there are 5% or more redoximorphic features; these may be redox concentrations and/or redox depletions.

---

<sup>1</sup> Redoximorphic features are formed by the processes of reduction, translocation, and/or oxidation of iron and manganese oxides. They are an indicator of seasonal water table elevations.

DEEP OBSERVATION HOLE NUMBER:  
 LOCATION:  
 DATE:

Depth (inches)	Horizon/ Layer	Matrix Color	Redoximorphic Features			Texture (USDA)	Coarse Fragments		Structure	Consistence	Reaction	Boundary	Other
			Depth	Color	Percent		Type	Percent					

ADDITIONAL NOTES:  
 \_\_\_\_\_  
 \_\_\_\_\_  
 \_\_\_\_\_

**Figure 8.4 Sample Test Pit Form**



## *9.0 Assorted Design Tools*

### **9.1 Infiltration Testing Requirements**

#### General Notes Pertinent to All Testing

1. For infiltration practices, a minimum field infiltration rate ( $f_c$ ) of 0.5 inches per hour is required; areas yielding a lower rate preclude these practices. If the minimum  $f_c$  exceeds two inches per hour, half of the  $WQ_v$  must be treated by an upstream BMP that does not allow infiltration. For F-1 and F-3 practices, no minimum infiltration rate is required if these facilities are designed with a “day-lighting” underdrain system; otherwise these facilities require a 0.5 inch per hour rate.
2. Number of required borings is based on the size of the proposed facility. Testing is done in two phases, (1) Initial Feasibility, and (2) Concept Design Testing.
3. Testing is to be conducted by a qualified professional. This professional shall be a registered professional engineer, a soils scientist or geologist, or certified per local soils certification program.

#### *Initial Feasibility Testing*

Feasibility testing is conducted to determine whether full-scale testing is necessary, and is meant to reduce screen unsuitable sites, and reduce testing costs. A soil boring is not required at this stage.

Initial testing involves either one field test per facility, regardless of type or size, or previous testing data, such as the following:

- \* septic percolation testing on-site, within 200 feet of the proposed BMP location, and on the same contour [can establish initial rate, water table and/or depth to bedrock]
- \* previous written geotechnical reporting on the site location as prepared by a qualified geotechnical consultant
- \* NRCS Soil Mapping *showing an unsuitable soil group* such as a hydrologic group “D” soil in a low-lying area

If the results of initial feasibility testing as determined by a qualified professional show that an infiltration rate of greater than 0.5 inches per hour is probable, then the number of *concept design test* pits shall be per the following table. An encased soil boring may be substituted for a test pit, if desired.

**Table 9-1 Infiltration Testing Summary Table**

Type of Facility	Initial Feasibility Testing	Concept Design Testing (initial testing yields a rate greater than 0.5in/hr)	Concept Design Testing (initial testing yields a rate lower than 0.5in/hr)
I-1 (trench/chamber)	1 field percolation test, test pit not required	1 infiltration test and 1 test pit per 200ft of trench	not acceptable practice
I-2 (basin)	1 field percolation test, test pit not required	1 infiltration test* and 1 test pit per 5,000 ft <sup>2</sup> of basin area	not acceptable practice
F-1 (sand filter)	1 field percolation test, test pit not required	1 infiltration test and 1 test pit per 5,000 ft <sup>2</sup> of filter area (no underdrains required**)	underdrains required
F-3 (bioretention)	1 field percolation test, test pit not required	1 infiltration test and 1 test pit per 5,000 ft <sup>2</sup> of filter area (no underdrains required**)	underdrains required

\*feasibility test information already counts for one test location

\*\* underdrain installation still strongly suggested

### Documentation

Infiltration testing data shall be documented, which shall also include a description of the infiltration testing method, if completed. This is to ensure that the tester understands the procedure.

### Test Pit/Boring Requirements (see **Chapter 8** for more information on soils and test pits)

- a. excavate a test pit or dig a standard soil boring to a depth of 4 ft below the proposed facility bottom
- b. determine depth to groundwater table (if within 4 ft of proposed bottom) upon initial digging or drilling, and again 24 hours later
- c. conduct Standard Penetration Testing (SPT) every 2 ft to a depth of 4 ft below the facility bottom
- d. determine USDA textures at the proposed bottom and 4 ft below the bottom of the BMP

- e. determine depth to bedrock (if within 4 ft of proposed bottom)
- f. The soil description should include all soil horizons.
- g. The location of the test pit or boring shall correspond to the BMP location; test pit/soil boring stakes are to be left in the field for inspection purposes and shall be clearly labeled as such.

#### Infiltration Testing Requirements

- a. Install casing (solid 5-inch diameter, 30-inch length) to 24 inches below proposed BMP bottom.
- b. Remove any smeared soiled surfaces and provide a natural soil interface into which water may percolate. Remove all loose material from the casing. Upon the tester's discretion, a two (2) inch layer of coarse sand or fine gravel may be placed to protect the bottom from scouring and sediment. Fill casing with *clean* water to a depth of 24 inches and allow to pre-soak for twenty-four hours.
- c. Twenty-four hours later, refill casing with another 24 inches of clean water and monitor water level (measured drop from the top of the casing) for 1 hour. Repeat this procedure (filling the casing each time) three additional times, for a total of four observations. Upon the tester's discretion, the final field rate may either be the average of the four observations, or the value of the last observation. The final rate shall be reported in *inches per hour*.
- d. May be done through a boring or open excavation.
- e. The location of the test shall correspond to the BMP location.
- f. Upon completion of the testing, the casings shall be immediately pulled, and the test pit shall be back-filled.

#### Laboratory Testing

- a. Grain-size sieve analysis and hydrometer tests where appropriate may be used to determine USDA soils classification and textural analysis. Visual field inspection by a qualified professional may also be used, provided it is documented. *The use of lab testing to establish infiltration rates is prohibited.*

## Bioretention Testing

All areas tested for application of F-3 facilities shall be back-filled with a suitable sandy loam planting media. The borrow source of this media, which may be the same or different from the bioretention area location itself, must be tested as follows:

If the borrow area is virgin, undisturbed soil, one test is required per 5,000 ft<sup>2</sup> of borrow area; the test consists of “grab” samples at one foot depth intervals to the bottom of the borrow area. All samples at the testing location are then mixed, and the resulting sample is then lab-tested to meet the following criteria:

- a) USDA minimum textural analysis requirements: A textural analysis is required from the site stockpiled topsoil. If topsoil is imported, then a texture analysis shall be performed for each location where the top soil was excavated.

Minimum requirements:

sand ~ 80%

silt 0 - 20%

clay 0 - 2%

organics 0 - 20%

- b) The soil shall be a uniform mix, free of stones, stumps, roots or other similar objects larger than one inch.
- c) Consult the bioretention construction specifications (**Chapter 6** above) for further guidance on preparing the soil for a bioretention area.

## 9.2 Miscellaneous BMP Details

Miscellaneous Design Schematics for Compliance with Performance Criteria:

Figure 9-1: Trash Rack for Low-flow Orifice

Figure 9-2: Expanded Trash Rack Protection for Low-flow Orifice

Figure 9-3: Internal Control for Orifice Protection

Figure 9-4: Half Round CMP Hood

Figure 9-5: Observation Well/Cleanout for Infiltration and Filtering Practices

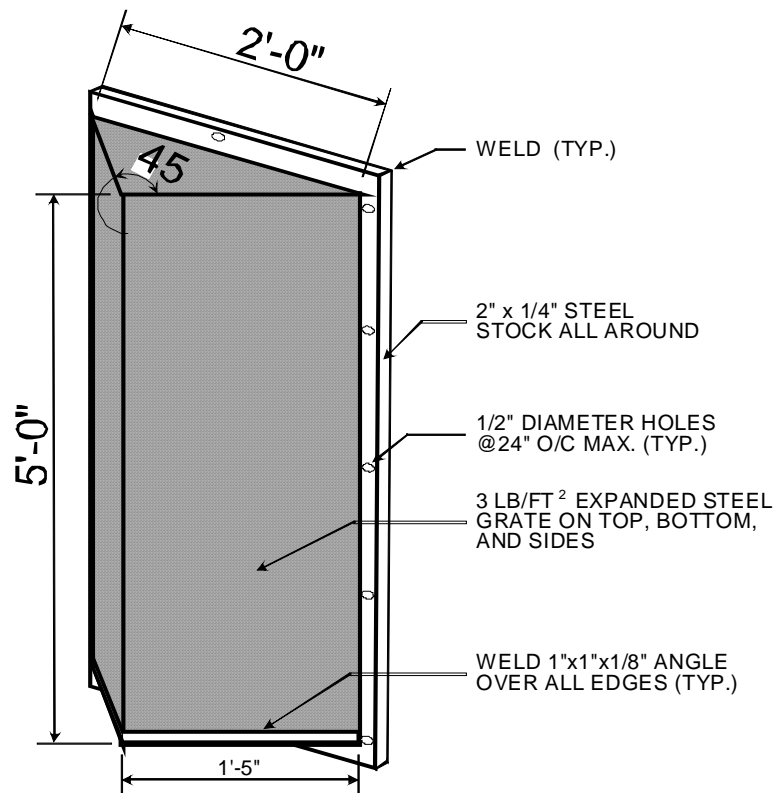
Figure 9-6: On-line Versus Off-line Schematic

Figure 9-7: Isolation/Diversion Structure

Figure 9-8: Concrete Level Spreader

### Low-flow Orifice Protection

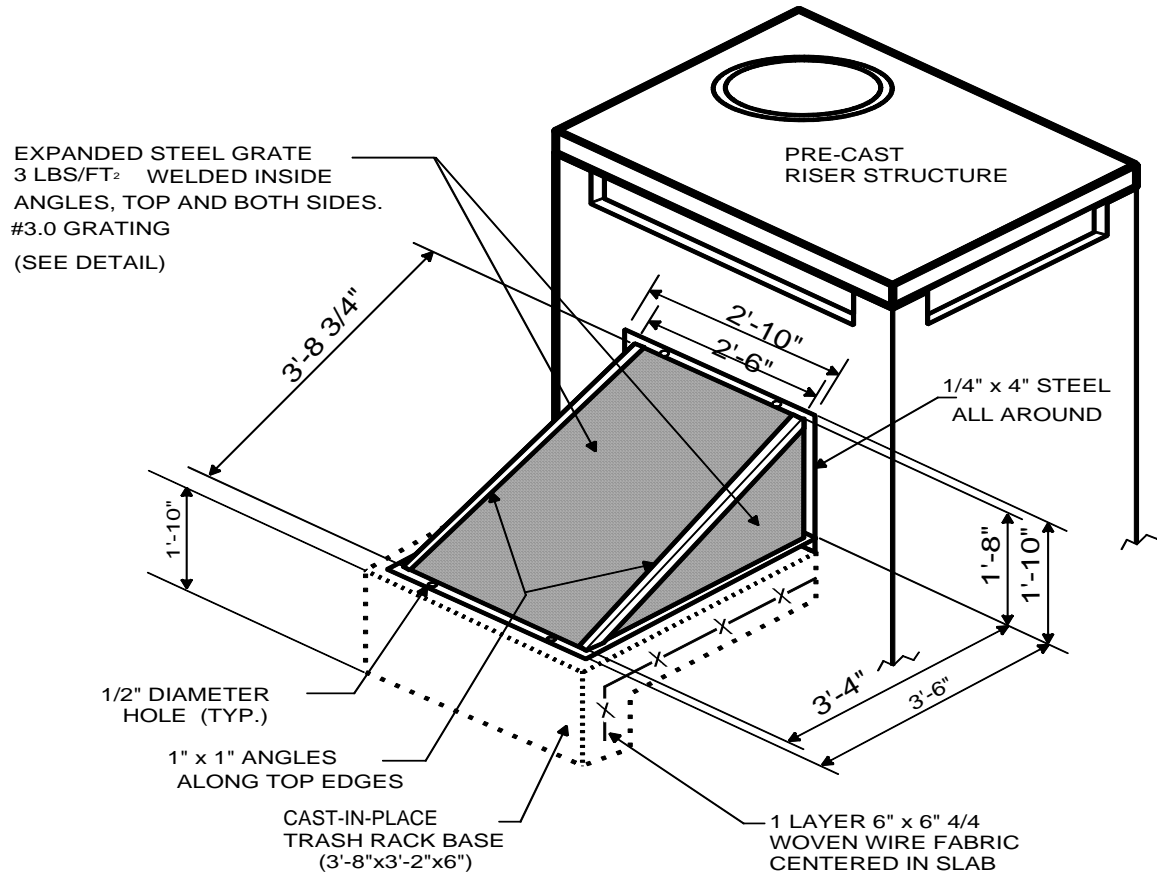
Outlet control structures typically use orifices of varying sizes to control discharge from certain stormwater BMPs. Low-flow orifices (typically <6" diameter) can easily clog with trash and vegetative debris. **Figures 9.1-9.4** illustrate a few examples of protective measures to prevent clogging and keep the BMPs functioning properly.



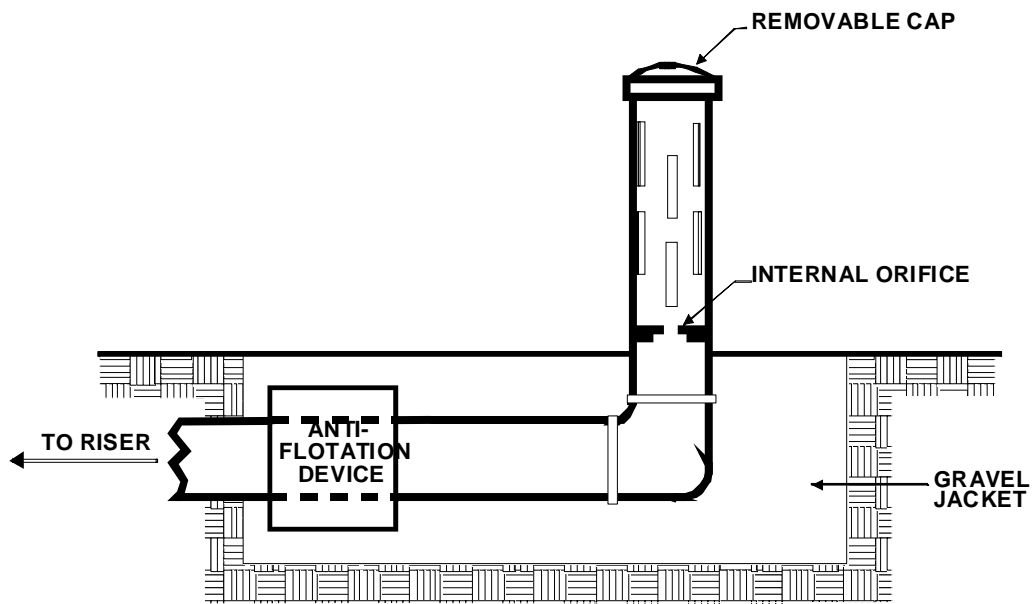
#### NOTES FOR TRASH RACK

1. TRASH RACK TO BE CENTERED OVER OPENING.
2. STEEL TO CONFORM TO ASTM A-36.
3. ALL SURFACES TO BE COATED WITH ZRC COLD GALVANIZING COMPOUND AFTER WELDING.

**Figure 9-1 Trash Rack Protection for Low-flow Orifice**

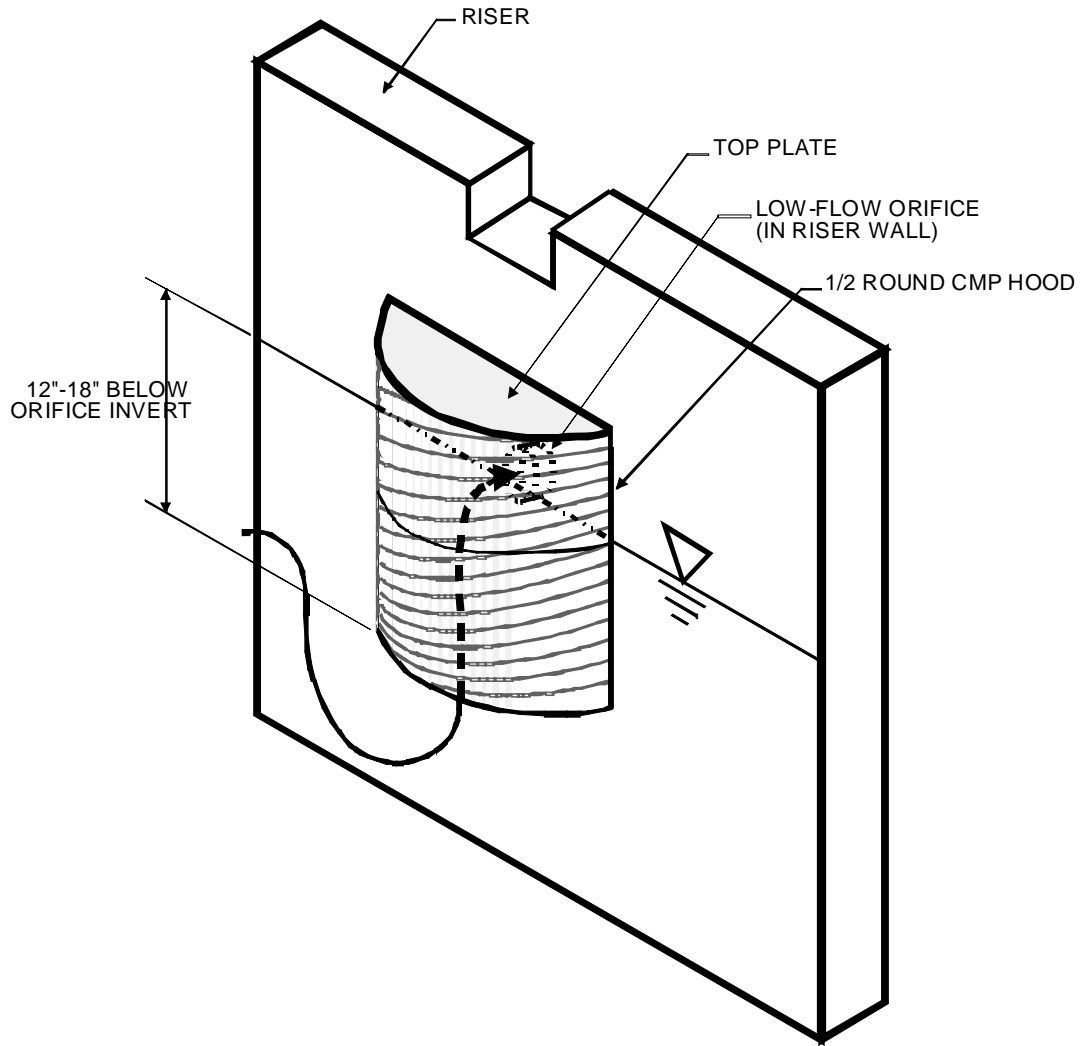


**Figure 9-2 Expanded Trash Rack Protection for Low-flow Orifice**



**Figure 9-3 Internal Control for Orifice Protection**

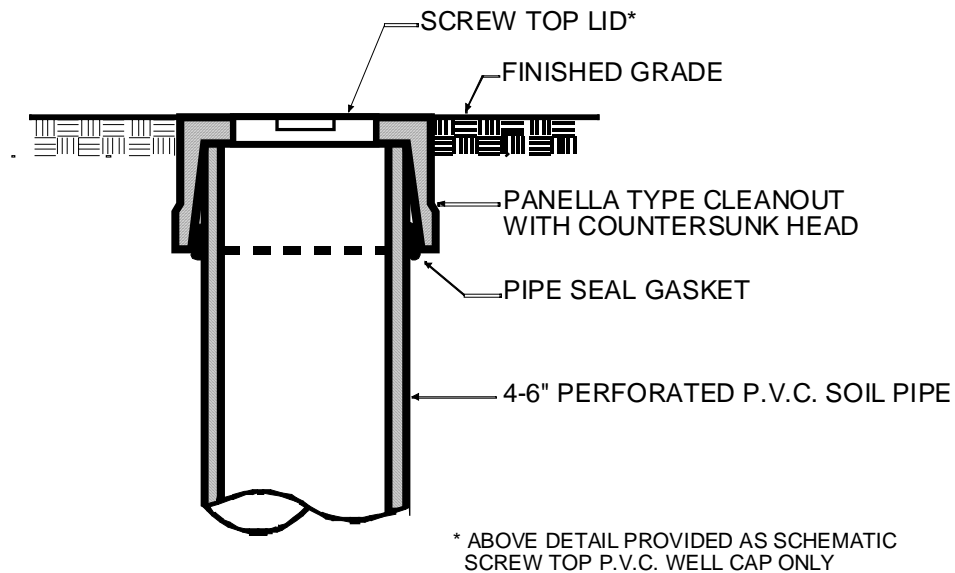




**Figure 9-4 Half Round CMP Hood (For Protection of Low-flow Orifice)**

### Observation Well/Cleanout

Infiltration and filtering practices require an observation well/cleanout for inspections and maintenance. One example that can be used in a parking lot is the flush-mounted observation well shown below in **Figure 9.5**.



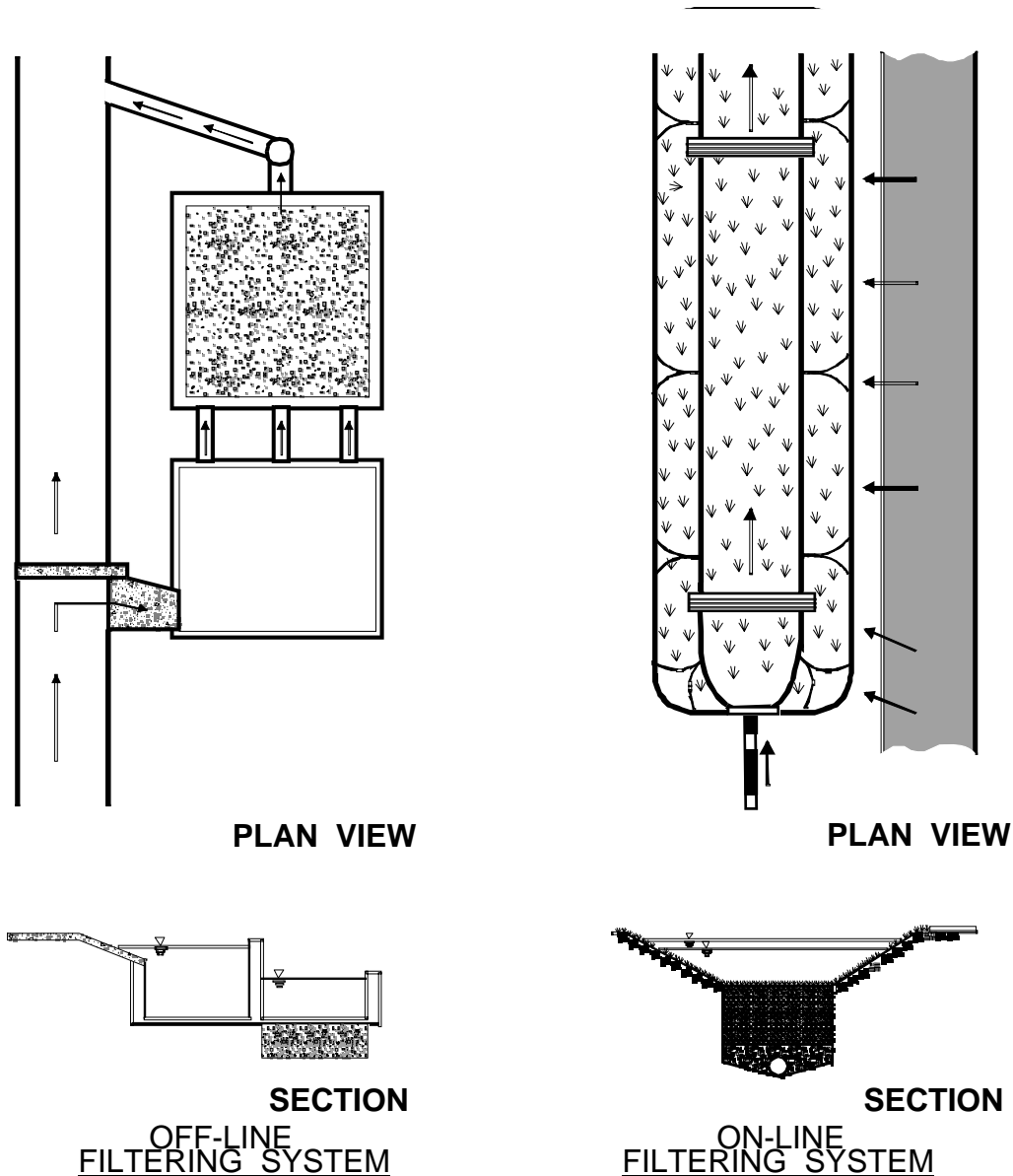
EACH OBSERVATION WELL / CLEANOUT SHALL INCLUDE THE FOLLOWING:

1. FOR AN UNDERGROUND FLUSH MOUNTED OBSERVATION WELL / CLEANOUT, PROVIDE A TUBE MADE OF NON-CORROSIVE MATERIAL, SCHEDULE 40 OR EQUAL, AT LEAST THREE FEET LONG.
2. THE TUBE SHALL HAVE A FACTORY ATTACHED CAST IRON OR HIGH IMPACT PLASTIC COLLAR WITH RIBS TO PREVENT ROTATION WHEN REMOVING SCREW TOP LID. THE SCREW TOP LID SHALL BE CAST IRON OR HIGH IMPACT PLASTIC THAT WILL WITHSTAND ULTRA-VIOLET RAYS.

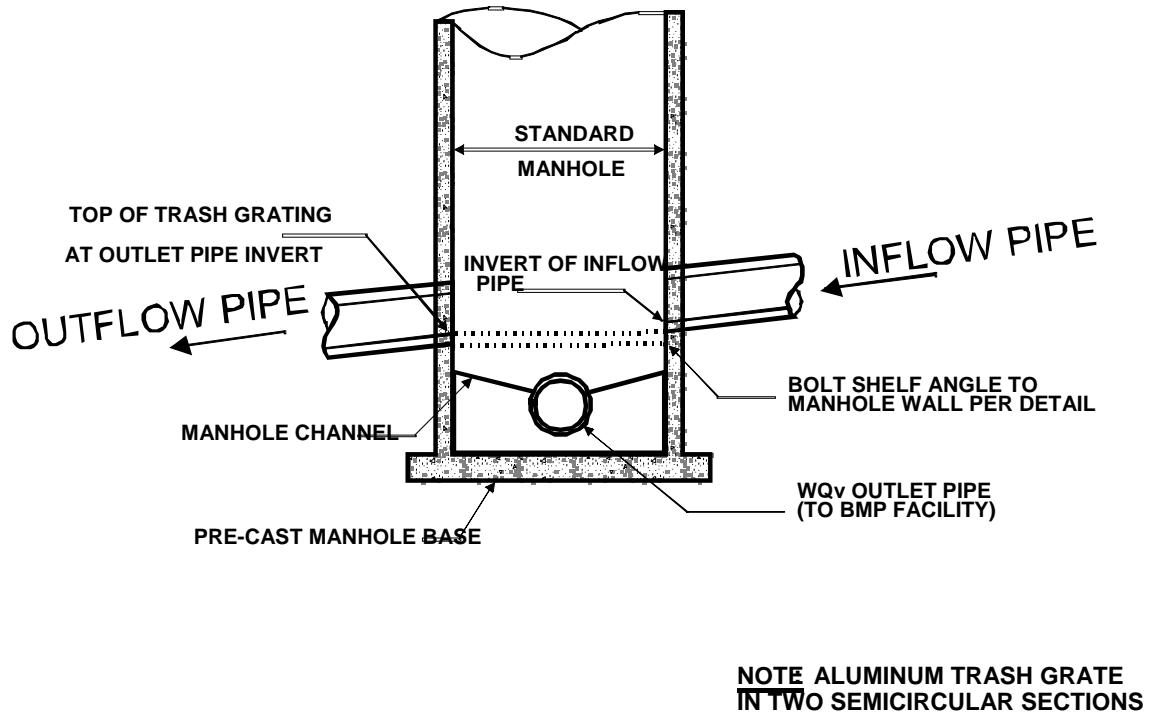
**Figure 9-5 Observation Well/Cleanout for Infiltration and Filtering Practices**

**On-line Versus Off-line**

Best management practices can be designed to receive all of the flow from a given area (on-line) or to receive only a portion of the flow (off-line), such as the water quality volume. Off-line BMPs may need to be paired with another practice for volume control, depending on the site characteristics. An example of an on-line vs. an off-line filtering practice is shown in **Figure 9.6**. **Figure 9.7** illustrates one example of a flow splitter that may be used to divert low flows to an off-line BMP for treatment or recharge while allowing larger flows to exit via the outflow pipe to a quantity control BMP or perhaps direct discharge to a water body, based on required site criteria.



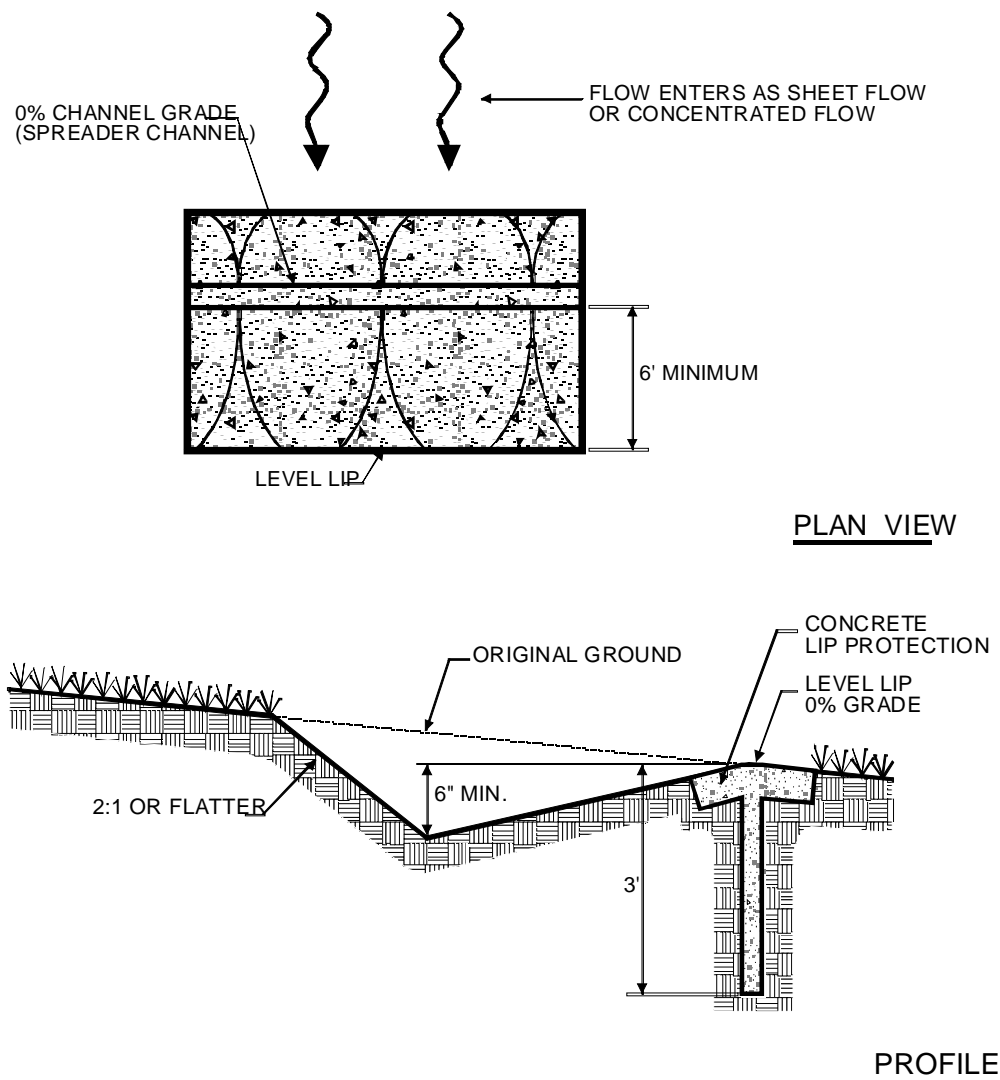
**Figure 9-6 On-Line Versus Off-Line Schematic**



**Figure 9-7 Isolation Diversion Structure**

**Level Spreaders**

Level spreaders are devices designed to uniformly distribute flow over a large area to prevent erosive flows and promote infiltration. There are several level spreader designs that differ based on the peak rate of inflow, the duration of use, the type of pollutant, and the site conditions. All designs follow the same basic principles: water enters the spreader through overland flow, a pipe, ditch or swale; the flow is distributed throughout a long linear shallow trench or behind a low berm; and then water flows over the berm/ditch uniformly along the entire length. Level spreaders can be used during construction or as a part of post-construction stormwater control. They are particularly useful to diffuse flow through vegetated buffers adjacent to waterbodies, in areas requiring a vegetative filter strip to pretreat runoff, and as a segment of a stormwater treatment series of BMPs where concentrated flow presents design constraints, such as with some filtering practices. One example of a level spreader is illustrated in **Figure 9.8**, and another is provided in **Volume I, Appendix A3**.



Source: Virginia Erosion and Sediment Control Handbook, Virginia Soil and Water Conservation Commission, 1980

**Figure 9-8 Concrete Level Spreader**

**<This page left blank intentionally>**

### 9.3 Hydrologic Analysis Tools

This section presents two hydrologic and hydraulic analysis tools that can be used to size best management practices (BMPs). The first is the TR-55 “short-cut” sizing technique, used to size practices designed for extended detention, slightly modified to incorporate the small flows necessary to provide channel protection. The second is a method used to determine the peak flow from water quality storm events. (This is often important when the water quality storm is diverted to an off-line water quality practice, with other larger events bypassed).

\*Please note that the rational method is not allowed for determining required volumes to meet the stormwater criteria. The rational method is appropriate for calculating peak discharge rates, and thus for sizing pipes, but not for volume-based requirements.

#### Storage Volume Estimation

This section presents a modified version of the TR-55 short-cut sizing approach. The method was modified by Harrington (1986), for applications where the peak discharge is very small compared with the uncontrolled discharge. This often occurs in the 1-year, 24-hour detention sizing.

Using TR-55 guidance (NRCS, 1986), the unit peak discharge ( $q_u$ ) can be determined based on the Curve Number and Time of Concentration. Knowing  $q_u$  and T (extended detention time),  $q_o/q_i$  (peak outflow discharge/peak inflow discharge) can be estimated from **Figure 9.9**.

**Figure 9.10** can also be used to estimate  $V_s/V_r$ . When  $q_o/q_i$  is  $<0.1$  and off the graph,  $V_s/V_r$  can also be calculated using the following equation:

$$V_s/V_r = 0.682 - 1.43 (q_o/q_i) + 1.64 (q_o/q_i)^2 - 0.804 (q_o/q_i)^3$$

Where:  $V_s$  = required storage volume (acre-feet)  
 $V_r$  = runoff volume (acre-feet)  
 $q_o$  = peak outflow discharge (cfs)  
 $q_i$  = peak inflow discharge (cfs)

The required storage volume can then be calculated by:

$$V_s = \frac{(V_s/V_r)(Q_d)(A)}{12}$$

Where:  $V_s$  and  $V_r$  are defined above  
 $Q_d$  = the developed runoff for the design storm (watershed inches)  
 $A$  = total drainage area (acres)

While the TR-55 short-cut method reports to incorporate multiple stage structures, experience has shown that an additional 10-15% storage is required when multiple levels of extended detention are provided.

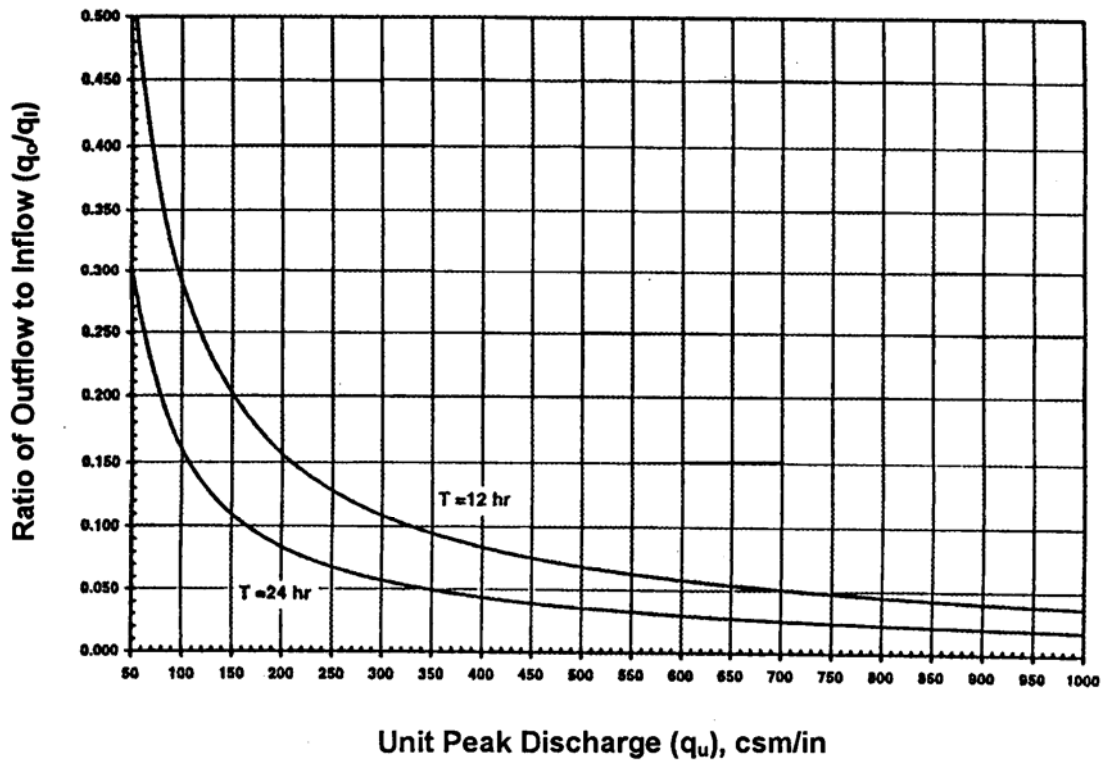


Figure 9.9. Detention Time vs. Discharge Ratios (Source: MDE, 2000)

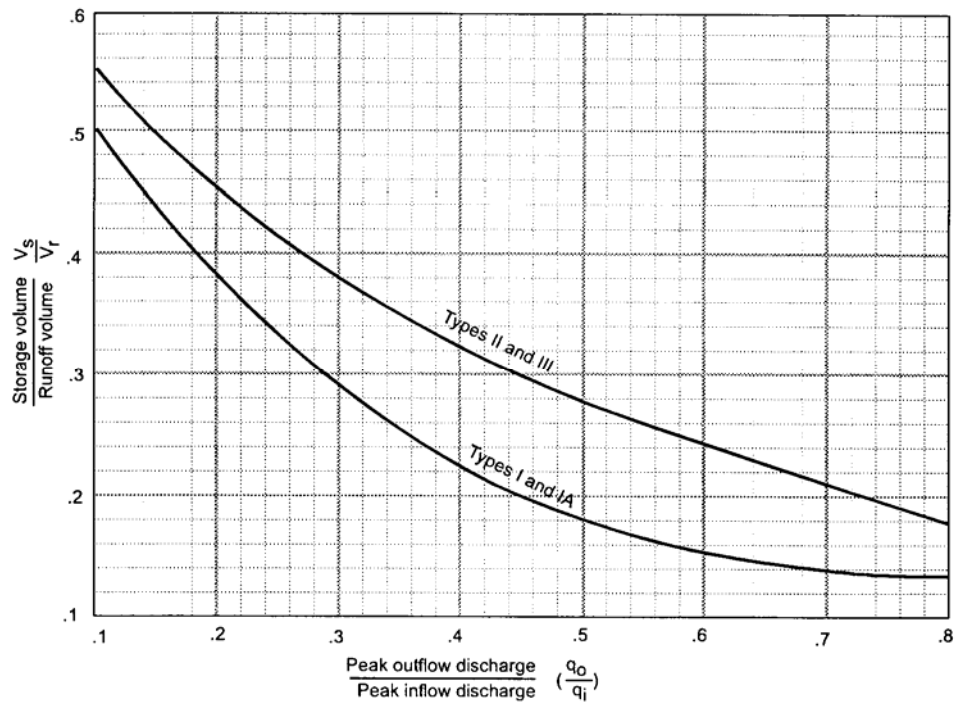


Figure 9.10. Approximate Detention Basin Routing For Rainfall Types I, IA, II, and III. (Source: TR-55, 1986)



### Water Quality Peak Flow Calculation

The peak rate of discharge for the water quality design storm is needed for the sizing of off-line diversion structures, such as sand filters and grass channels. An arbitrary storm would need to be chosen using the Rational method, and conventional SCS methods have been found to underestimate the volume and rate of runoff for rainfall events less than 2 inches. This discrepancy in estimating runoff and discharge rates can lead to situations where a significant amount of runoff by-passes the filtering treatment practice due to an inadequately sized diversion structure and leads to the design of undersized bypass channels.

The following procedure can be used to estimate peak discharges for small storm events. It relies on the Water Quality Volume and the simplified peak flow estimating method above. A brief description of the calculation procedure is presented below.

Using the water quality volume ( $WQ_v$ ), a corresponding Curve Number (CN) is computed utilizing the following equation:

$$CN = 1000/[10 + 5P + 10Q - 10(Q^2 + 1.25 QP)^{1/2}]$$

where      P      =      rainfall, in inches (use 0.8 or 1.5 in for the Water Quality Storm)  
               Q      =      runoff volume, in watershed inches (equal to  $WQ_v \div \text{area}$ )

Once a CN is computed, the time of concentration ( $t_c$ ) is computed.

Using the computed CN,  $t_c$  and drainage area (A), in acres; the peak discharge ( $Q_p$ ) for the water quality storm event is computed (Type IA).

Read initial abstraction (Ia), compute Ia/P

Read the unit peak discharge ( $q_u$ ) for appropriate  $t_c$

Using the water quality volume ( $WQ_v$ ), compute the peak discharge ( $Q_p$ )

$$Q_p = q_u * A * WQ_v$$

where       $Q_p$     =    the peak discharge, in cfs  
                $q_u$     =    the unit peak discharge, in cfs/mi<sup>2</sup>/inch  
               A      =    drainage area, in square miles  
                $WQ_v$  =    Water Quality Volume, in watershed inches

**<This page left blank intentionally>**



## ***GLOSSARY***

AQUATIC BENCH - A ten- to fifteen-foot wide bench which is located around the inside perimeter of a permanent pool and is normally vegetated with aquatic plants; the goal is to provide pollutant removal and enhance safety in areas using stormwater ponds.

AQUIFER - A geological formation that contains and transports groundwater.

“AS-BUILT” - Drawing or certification of conditions as they were actually constructed.

BASEFLOW - The stream discharge from groundwater.

BIORETENTION - A water quality practice that utilizes landscaping and soils to treat urban stormwater runoff by collecting it in shallow depressions, before filtering through a fabricated planting soil media.

BUFFER - The area immediately surrounding a best management practice that acts as filter to remove pollutants and provide infiltration of stormwater prior to reaching the BMP. Provides a separation barrier to adjacent development.

CHANNEL - A natural stream that conveys water; a ditch or channel excavated for the flow of water.

CHANNEL PROTECTION (Cp<sub>v</sub>) - A design criteria which requires 24-hour detention of the one-year, post-developed, 24 hour storm event for the control of stream channel erosion.

CHANNEL STABILIZATION - Erosion prevention and stabilization of velocity distribution in a channel using jetties, drops, revetments, structural linings, vegetation and other measures.

CLAY (SOILS) - 1. A mineral soil separate consisting of particles less than 0.002 millimeter in equivalent diameter. 2. A soil texture class. 3. (Engineering) A fine-grained soil (more than 50 percent passing the No. 200 sieve) that has a high plasticity index in relation to the liquid limit. (Unified Soil Classification System)

COMPACTION (SOILS) - Any process by which the soil grains are rearranged to decrease void space and bring them in closer contact with one another, thereby increasing the weight of solid material per unit of volume, increasing the shear and bearing strength and reducing permeability.

CONTOUR - 1. An imaginary line on the surface of the earth connecting points of the same elevation. 2. A line drawn on a map connecting points of the same elevation.

CURVE NUMBER (CN) - A numerical representation of a given area's hydrologic soil group, plant cover, impervious cover, interception and surface storage derived in accordance with

Natural Resources Conservation Service methods. This number is used to convert rainfall volume into runoff volume.

CUT - Portion of land surface or area from which earth has been removed or will be removed by excavation; the depth below original ground surface to excavated surface.

DETENTION - The temporary storage of storm runoff in a BMP with the goals of controlling peak discharge rates and providing gravity settling of pollutants.

DETENTION STRUCTURE - A structure constructed for the purpose of temporary storage of stream flow or surface runoff and gradual release of stored water at controlled rates.

DISTURBED AREA - An area in which the natural vegetative soil cover has been removed or altered and, therefore, is susceptible to erosion.

DIVERSION - A channel with a supporting ridge on the lower side constructed across the slope to divert water from areas where it is in excess to sites where it can be used or disposed of safely. Diversions differ from terraces in that they are individually designed.

DRAINAGE - 1. The removal of excess surface water or ground water from land by means of surface or subsurface drains. 2. Soils characteristics that affect natural drainage.

DRAINAGE AREA (WATERSHED) - All land and water area from which runoff may run to a common (design) point.

DRY SWALE - An open drainage channel explicitly designed to detain and promote the filtration of stormwater runoff through an underlying fabricated soil media.

EMERGENCY SPILLWAY - A dam spillway designed and constructed to discharge flow in excess of the principal spillway design discharge.

EROSION - 1. The wearing away of the land surface by running water, wind, ice, or other geological agents, including such processes as gravitational creep. 2. Detachment and movement of soil or rock fragments by water, wind, ice or gravity. The following terms are used to describe different types of water erosion:

Accelerated erosion - Erosion much more rapid than normal, natural or geologic erosion, primarily as a result of the influence of the activities of man or, in some cases, of other animals or natural catastrophes that expose base surfaces, for example, fires.

Gully erosion - The erosion process whereby water accumulates in narrow channels and, over short periods, removes the soil from this narrow area to considerable depths, ranging from 1 or 2 feet to as much as 75 to 100 feet.

Rill erosion - An erosion process in which numerous small channels only several inches deep are formed. See rill.

Sheet erosion - The spattering of small soil particles caused by the impact of raindrops on wet soils. The loosened and spattered particles may or may not subsequently be removed by surface runoff.

EROSIVE VELOCITIES - Velocities of water that are high enough to wear away the land surface. Exposed soil will generally erode faster than stabilized soils. Erosive velocities will vary according to the soil type, slope, structural, or vegetative stabilization used to protect the soil.

EXTENDED DETENTION (ED) - A stormwater design feature that provides for the gradual release of a volume of water over a 12- to 48-hour interval in order to increase settling of urban pollutants and protect downstream channels from frequent storm events.

FILTER STRIP - A strip of permanent vegetation above ponds, diversions and other structures to retard flow of runoff water, causing deposition of transported material, thereby reducing sediment flow.

FLOODPLAIN - Areas adjacent to a stream or river that are subject to flooding or inundation during a storm event that occurs, on average, once every 100 years (or has a likelihood of occurrence of 1/100 in any given year).

FLOW SPLITTER - An engineered, hydraulic structure designed to divert a percentage of storm flow to a BMP located out of the primary channel, or to direct stormwater to a parallel pipe system, or to bypass a portion of baseflow around a BMP.

FOREBAY - Storage space located near a stormwater BMP inlet that serves to trap incoming coarse sediments before they accumulate in the main treatment area.

GRADE - 1. The slope of a road, channel or natural ground. 2. The finished surface of a canal bed, roadbed, top of embankment, or bottom of excavation; any surface prepared for the support of construction, like paving or laying a conduit. 3. To finish the surface of a canal bed, roadbed, top of embankment or bottom of excavation.

GRASS CHANNEL - An open vegetated channel used to convey runoff and to provide treatment by filtering out pollutants and sediments.

GRAVEL - 1. Aggregate consisting of mixed sizes of 1/4 inch to 3-inch particles that normally occur in or near old streambeds and have been worn smooth by the action of water. 2. A soil having particle sizes, according to the Unified Soil Classification System, ranging from the No. 4 sieve size angular in shape as produced by mechanical crushing.

GROUND COVER - Plants that are low growing and provide a thick growth that protects the soil as well as providing some beautification of the area occupied.

GULLY - A channel or miniature valley cut by concentrated runoff through which water commonly flows only during and immediately after heavy rains. The distinction between gully and rill is one of depth. A gully is sufficiently deep that it would not be obliterated by normal tillage operations, whereas a rill is of lesser depth and would be smoothed by ordinary farm tillage.

HEAD (HYDRAULICS) - 1. The height of water above any plane of reference. 2. The energy, either kinetic or potential, possessed by each unit weight of a liquid expressed as the vertical height through which a unit weight would have to fall to release the average energy possessed. Used in various terms such as pressure head, velocity head, and head loss.

HERBACEOUS PERENNIAL (PLANTS) - A plant whose stems die back to the ground each year.

HOTSPOT - Area where land use or activities generate highly contaminated runoff, with concentrations of pollutants in excess of those typically found in stormwater.

HYDROGRAPH - A graph showing variation in stage (depth) or discharge of a stream of water over a period of time.

HYDROLOGIC SOIL GROUP (HSG) - A Natural Resource Conservation Service classification system in which soils are categorized into four runoff potential groups. The groups range from A soils, with high permeability and little runoff production, to D soils, which have low permeability rates and produce much more runoff.

IMPERVIOUS COVER (I) - Those surfaces in the urban landscape that cannot effectively infiltrate rainfall consisting of building rooftops, pavement, sidewalks, driveways, coral surfaces (e.g., driveways, lots, and yards), etc.

INFILTRATION RATE ( $f_c$ ) - The rate at which stormwater percolates into the subsoil measured in inches per hour.

LEVEL SPREADER - A device for distributing stormwater uniformly over the ground surface as sheet flow to prevent concentrated, erosive flows and promote infiltration.

MICROPOOL - A smaller permanent pool that is incorporated into the design of larger stormwater ponds to avoid resuspension or settling of particles and minimize impacts to adjacent natural features.

MULCH - Covering on surface of soil to protect and enhance certain characteristics, such as water retention qualities.

OUTFALL - The point where water flows from a conduit, stream, or drain.

OFF-LINE - A stormwater management system designed to manage a storm event by diverting a percentage of stormwater events from a stream or storm drainage system.

ON-LINE - A stormwater management system designed to manage stormwater in its original stream or drainage channel.

OPEN CHANNELS - Also known as swales, grass channels, and biofilters. These systems are used for the conveyance, retention, infiltration and filtration of stormwater runoff.

OUTLET - The point at which water discharges from such things as a stream, river, lake, tidal basin, pipe, channel or drainage area.

OUTLET CONTROL STRUCTURE - A hydraulic structure placed at the outlet of a channel, spillway, pond, etc., for the purpose of dissipating energy, providing a transition to the channel or pipe downstream, while achieving the discharge rates for specified designs.

PEAK DISCHARGE RATE - The maximum instantaneous rate of flow during a storm, usually in reference to a specific design storm event.

PERMEABILITY - The rate of water movement through the soil column under saturated conditions

pH - A number denoting the common logarithm of the reciprocal of the hydrogen ion concentration. A pH of 7.0 denotes neutrality, higher values indicate alkalinity, and lower values indicate acidity.

PIPING - Removal of soil material through subsurface flow channels or “pipes” developed by seepage water.

PLUGS - Pieces of vegetation, usually cut with a round tube, which can be used to propagate the plant by vegetative means.

POCKET WETLAND - A stormwater wetland designed for treatment of small drainage area (<5 acres) runoff and which has little or no baseflow available to maintain water elevations and relies on ground water to maintain a permanent pool.

PONDSCAPING - Landscaping around stormwater ponds that emphasizes native vegetative species to meet specific design intentions. Species are selected for up to six zones in the pond and its surrounding buffer, based on their ability to tolerate inundation and/ or soil saturation.

PRETREATMENT - Techniques employed in stormwater BMPs to provide storage or filtering to help trap coarse materials before they enter the system.

PRINCIPAL SPILLWAY - The primary pipe or weir that carries baseflow and storm flow through the embankment.

REDEVELOPMENT - New development activities on previously developed land.

REDOXIMORPHIC FEATURES - Features in the soil profile that are formed by the processes of reduction, translocation, and/or oxidation of iron and manganese oxides. They are an indicator of seasonal water table elevations.

RETENTION - The amount of precipitation on a drainage area that does not escape as runoff. It is the difference between total precipitation and total runoff.

RIGHT-OF-WAY (R/W) - Right of passage, as over another's property. A route that is lawful to use. A strip of land acquired for transport or utility construction.

RISER - A type of outlet control structure that consists of a vertical pipe that extends from the bottom of a pond BMP and houses the control devices (weirs/orifices) to achieve the discharge rates for specified designs.

RUNOFF (HYDRAULICS) - That portion of the precipitation on a drainage area that is discharged from the area in the stream channels. Types include surface runoff, ground water runoff or seepage.

SAFETY BENCH - A flat area above the permanent pool and surrounding a stormwater pond designed to provide a separation from the pond pool and adjacent slopes.

SAND - 1. (Agronomy) A soil particle between 0.05 and 2.0 millimeters in diameter. 2. A soil textural class. 3. (Engineering) According to the Unified Soil Classification System, a soil particle larger than the No. 200 sieve (0.074mm) and passing the No. 4 sieve (approximately 1/4 inch).

SEDIMENT - Solid material, both mineral and organic, that is in suspension, is being transported, or has been moved from its site of origin by air, water, gravity, or ice and has come to rest on the earth's surface either above or below sea level.

SEEPAGE - 1. Water escaping through or emerging from the ground. 2. The process by which water percolates through the soil.

SETBACKS - The minimum distance requirements for location of a structural BMP in relation to roads, wells, septic fields, other structures.

SHEET FLOW - Water, usually storm runoff, flowing in a thin layer over the ground surface.

SIDE SLOPES (ENGINEERING) - The slope of the sides of a channel, dam or embankment. It is customary to name the horizontal distance first, as 1.5 to 1, or frequently, 1 ½: 1, meaning a horizontal distance of 1.5 feet to 1 foot vertical.

SILT - 1. (Agronomy) A soil separate consisting of particles between 0.05 and 0.002 millimeter in equivalent diameter. 2. A soil textural class. 3. (Engineering) According to the Unified Soil Classification System a fine-grained soil (more than 50 percent passing the No. 200 sieve) that has a low plasticity index in relation to the liquid limit.

SOIL TEST - Chemical analysis of soil to determine needs for fertilizers or amendments for species of plant being grown.

SPILLWAY - An open or closed channel, or both, used to convey excess water from a reservoir. It may contain gates, either manually or automatically controlled to regulate the discharge of excess water.

STABILIZATION - Providing adequate measures, vegetative and/or structural that will prevent erosion from occurring.

STAGE (HYDRAULICS) - The variable water surface or the water surface elevation above any chosen datum.

STORMWATER FILTERING - Stormwater treatment methods that utilize an artificial media to filter out pollutants entrained in urban runoff.

STORMWATER PONDS - A land depression or impoundment created for the detention or retention of stormwater runoff.

STORMWATER WETLANDS - Shallow, constructed pools that capture stormwater and allow for the growth of characteristic wetland vegetation.

STREAM BUFFERS - Zones of variable width that are located along both sides of a stream and are designed to provide a protective natural area along a stream corridor.

STRUCTURAL BMPs - Devices that are constructed to provide temporary storage and treatment of stormwater runoff.

SUBGRADE - The soil prepared and compacted to support a structure or a pavement system.

TECHNICAL RELEASE No. 55 (TR-55) - A watershed hydrology model developed by the Soil Conservation Service (now NRCS) used to calculate runoff volumes and provide a simplified routing for storm events through ponds.

TEMPORARY SEEDING - A seeding which is made to provide temporary cover for the soil while waiting for further construction or other activity to take place.

TIME OF CONCENTRATION - Time required for water to flow from the most remote point of a watershed, in a hydraulic sense, to the outlet.

TOE (OF SLOPE) - Where the slope stops or levels out. Bottom of the slope.

“TOKEN” SPILLWAY - Those spillways placed above the water elevation of the largest managed storm, for emergencies only – not a spillway used to regulate flow from a managed storm.



TOPSOIL - Fertile or desirable soil material used to top dress road banks, subsoils, parent material, etc.

TOTAL SUSPENDED SOLIDS - The total amount of soils particulate matter that is suspended in the water column.

TRASH RACK - Grill, grate or other device at the intake of a channel, pipe, drain or spillway for the purpose of preventing oversized debris from entering the structure.

ULTRA-URBAN - Densely developed urban areas in which little pervious surface exists.

VELOCITY HEAD - Head due to the velocity of a moving fluid, equal to the square of the mean velocity divided by twice the acceleration due to gravity (32.16 feet per second per second).

WATER QUALITY VOLUME (WQ<sub>v</sub>) - The storage needed to capture and treat 90% of the average annual stormwater runoff volume for sites located within or discharging to high quality water and “hotspot” sites, and 80% of the runoff volume for sites located within or discharging to moderate quality water.

WATERSHED INCHES - Watershed inches are used to compare stormwater volume requirements between sites of varying sizes. Required volumes in acre-feet can be converted to watershed inches by dividing by the total site area in acres and multiplying by 12 inches/feet.

WET SWALE - An open drainage channel or depression, explicitly designed to retain water or intercept groundwater for water quality treatment.

**<This page left blank intentionally>**



## *REFERENCES*

- Arendt, Randall. 1994. *Designing Open Space Subdivisions: A Practical Step-by-Step Approach*. Natural Lands Trust, Inc. Media, PA. Available from [www.natlands.org](http://www.natlands.org) or [www.greenerprospects.com](http://www.greenerprospects.com)
- Arendt, Randall. 1996. *Conservation Design for Subdivisions: A Practical Guide to Creating Open Space Networks*. American Planning Association. Chicago, IL. Available from the American Planning Association at [www.planning.org](http://www.planning.org)
- Atlanta Regional Commission. August 2001. *Georgia Stormwater Management Manual*. Atlanta, GA. Available from [www.georgiastormwater.com](http://www.georgiastormwater.com)
- Cappiella, K., T. Schueler, T. Wright. 2004. *Urban Watershed Forestry Manual*. Available from [www.cwp.org](http://www.cwp.org)
- Center for Watershed Protection. 2000. "An Introduction to Better Site Design." *Watershed Protection Techniques*. Vol. 3.
- Center for Watershed Protection. 1998. *Better Site Design: A Handbook for Changing Development Rules in Your Community*. Available from [www.cwp.org](http://www.cwp.org)
- Low Impact Development (LID) Center website: <http://www.lowimpactdevelopment.org/>
- Massachusetts Executive Office of Environmental Affairs (EOEA). 2005. *Smart Growth Toolkit*. Boston, MA. Available from <http://www.mass.gov/envir/>
- Metropolitan Area Planning Council (MAPC). 2005. *Massachusetts Low Impact Development Toolkit Fact Sheets*. Metropolitan Area Planning Council. Boston, MA. Available from [www.mapc.org/lid](http://www.mapc.org/lid)
- MPCA. 1989. *Best Management Practices for Minnesota*. Minnesota Pollution Control Agency. Minneapolis, MN.
- NRCS. Soils Surveys for CNMI and Guam.

- Prince George's County, MD. June 1999. *Low-Impact Development Design Strategies: An Integrated Design Approach*. Prince George's County, Maryland, Department of Environmental Resources, Largo, Maryland. Available from [www.epa.gov](http://www.epa.gov)
- Rhode Island Department of Environmental Management. January 2005. *The Urban Environmental Design Manual*. Rhode Island Department of Environmental Management, Providence, Rhode Island. Available from <http://www.dem.state.ri.us/programs/bpoladm/suswshed/pubs.htm>
- Schoeneberger, P.J., Wysocki, D.A., Benham, E.C., and Broderson, W.D. (editors), 2002. *Field book for describing and sampling soils, Version 2.0*. Natural Resources Conservation Service, National Soil Survey Center, Lincoln, NE.
- Schueler, T. 1992. *Design of Stormwater Wetland Systems: guidelines for creating diverse and effective stormwater wetlands in the mid-Atlantic Region*. Prepared for: Nonpoint Source Subcommittee of the Regional Water Committee. Metropolitan Washington Council of Governments, Washington, DC.
- Schueler, T. 1995. *Site Planning for Urban Stream Protection*. Prepared for: Metropolitan Washington Council of Governments. Washington, DC. Center for Watershed Protection, Ellicott City, MD. Available from [www.cwp.org](http://www.cwp.org)
- USDA. 1986. TR-55 Urban Hydrology for Small Watersheds.
- USEPA. 2002. Onsite Wastewater Treatment Systems Manual. EPA/625/R-00/008. <http://www.epa.gov/ORD/NRMRL/Pubs/625R00008/625R00008.htm>.
- Vermont Agency of Natural Resources. April 2002. *The Vermont Stormwater Management Manual*. Waterbury, VT. Available from [www.vtwaterquality.org/stormwater.htm](http://www.vtwaterquality.org/stormwater.htm).
- Winer, R. 2000. National Pollutant Removal Database for Stormwater Treatment Practices: 2nd Edition. Center for Watershed Protection. Ellicott City, MD.
- [www.epa.gov/ebtpages/envismartgrowth.html](http://www.epa.gov/ebtpages/envismartgrowth.html) Environmental Protection Agency (EPA) site on smart growth including a focus on community based approaches to reducing sprawl.